

# HFC/HVC + ERC 5°

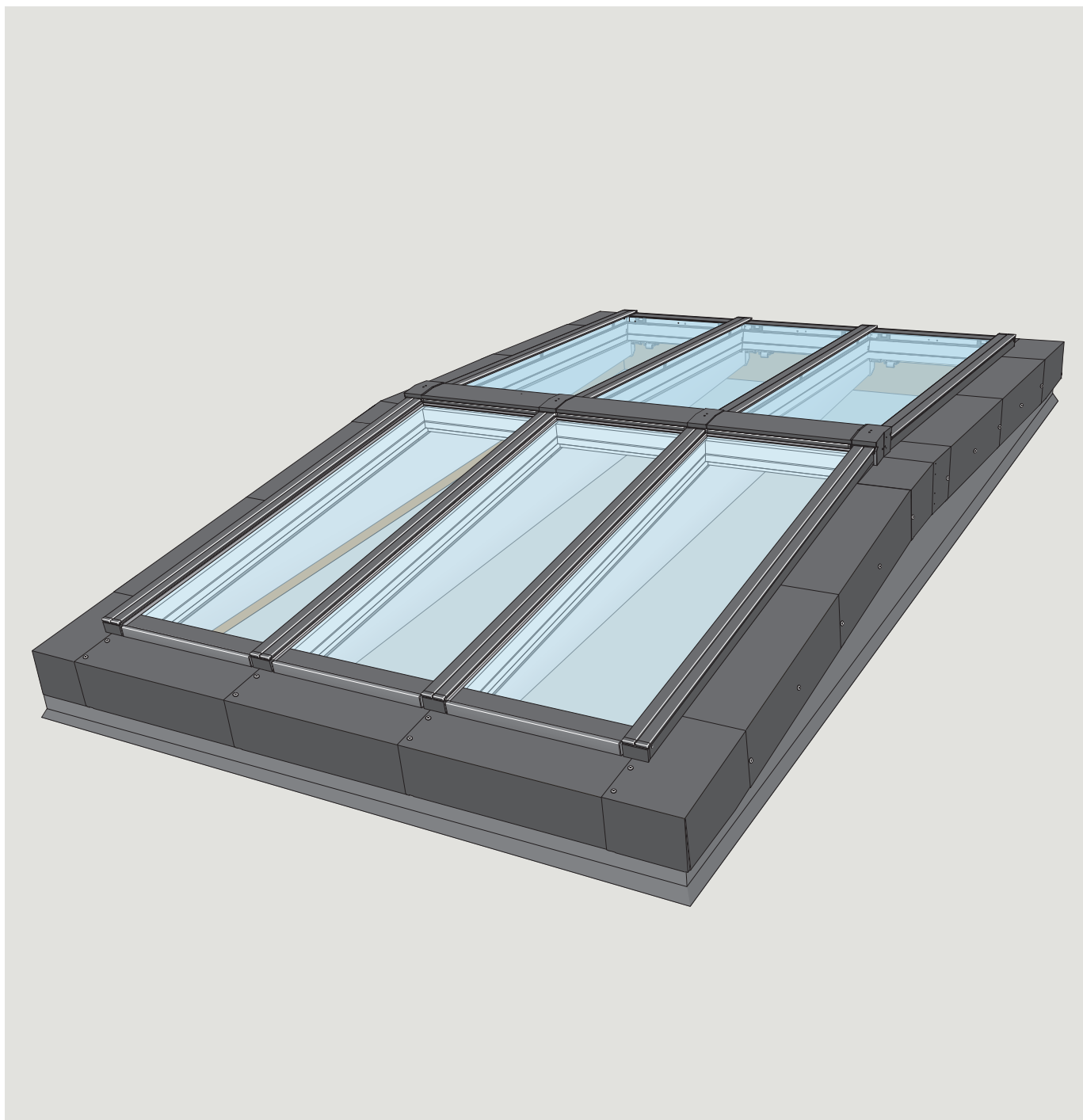

## A1-R<sub>5°</sub>



HFC/HVC + ELC



HVC CE all

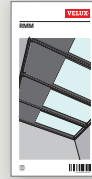

RMM

## A2-R<sub>5°</sub>

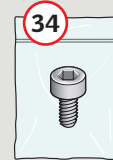
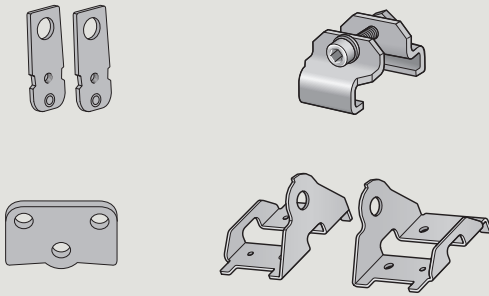

M8 x 10 mm

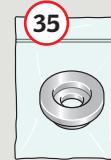

M8

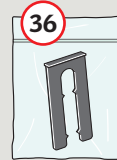

36

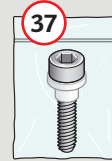

M8 x 30 mm

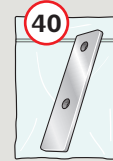

40



42

M8

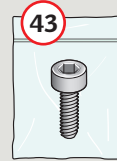

43

M8 x 20 mm

## A3-R<sub>5°</sub>

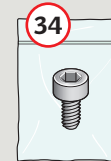
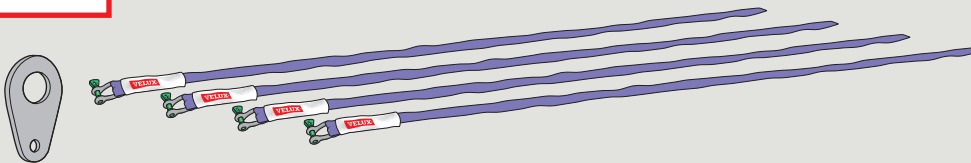

M8 x 10 mm



35

M8

## A4-R<sub>5°</sub>



## A5-R<sub>5°</sub>

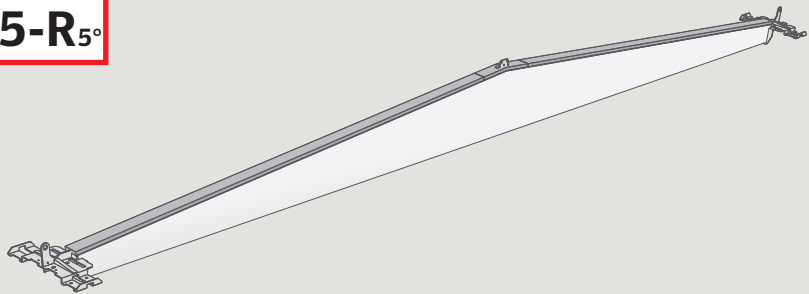

## A6-R<sub>5°</sub>

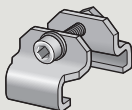

## B1-R<sub>5°</sub>

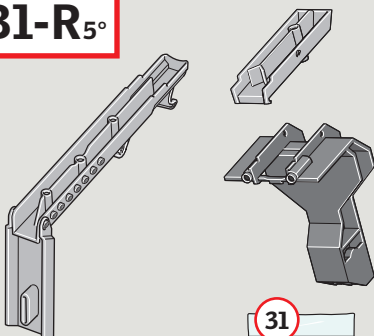

5,5 x 27 mm

## B2-R<sub>5°</sub>

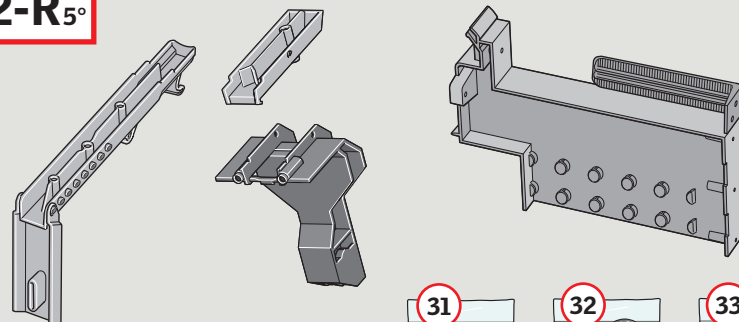

5,5 x 27 mm



4 x 45 mm

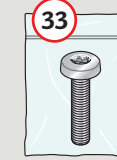

M4 x 25 mm

**C1-R<sub>5°</sub>**

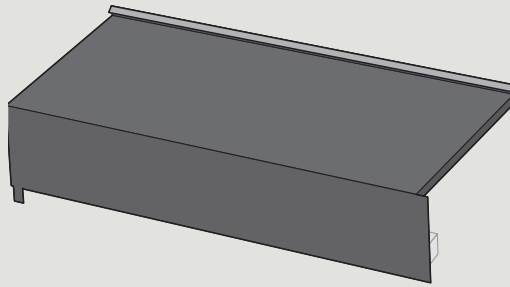

**C3-R<sub>5°</sub>**

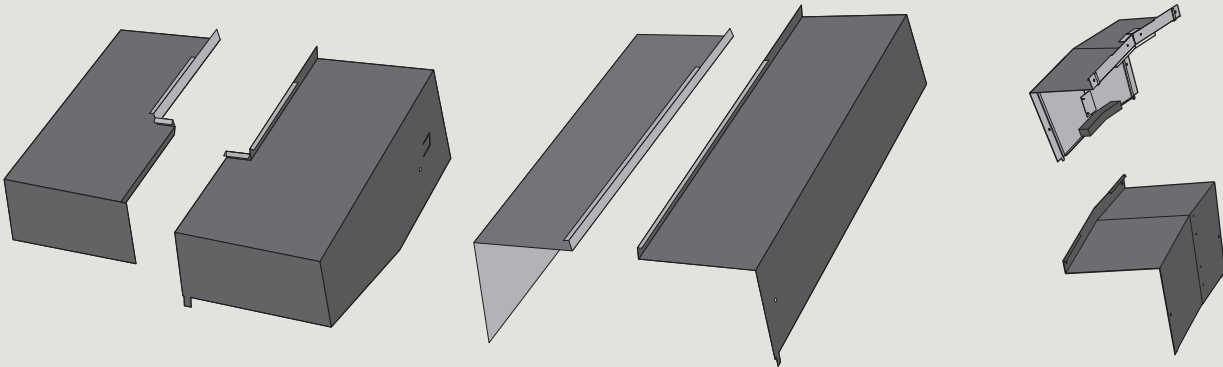

**D1-R<sub>5°</sub>**



**D2-R<sub>5°</sub>**

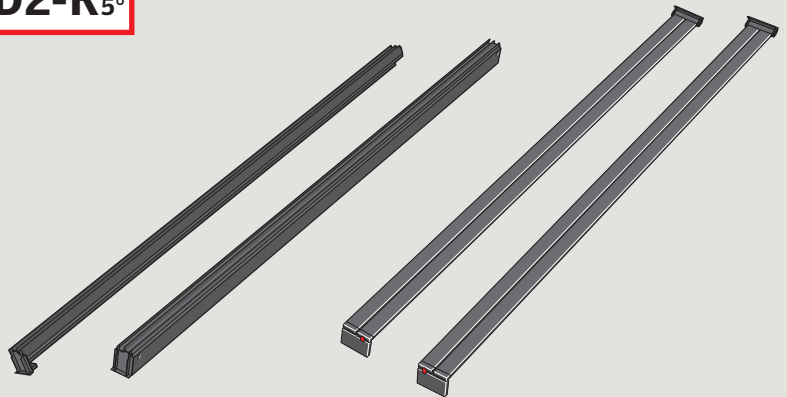

**D3-R<sub>5°</sub>**

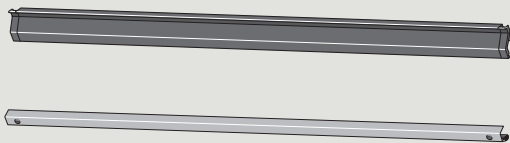

**D4-R<sub>5°</sub>**

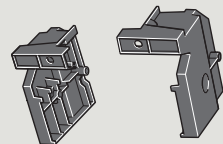

**E1-R<sub>5°</sub>**

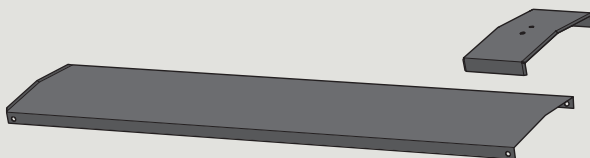

**E2-R<sub>5°</sub>**

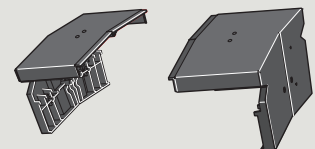



**BCX**

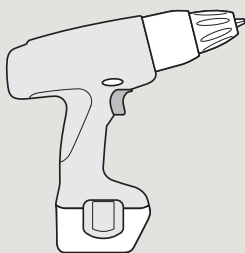
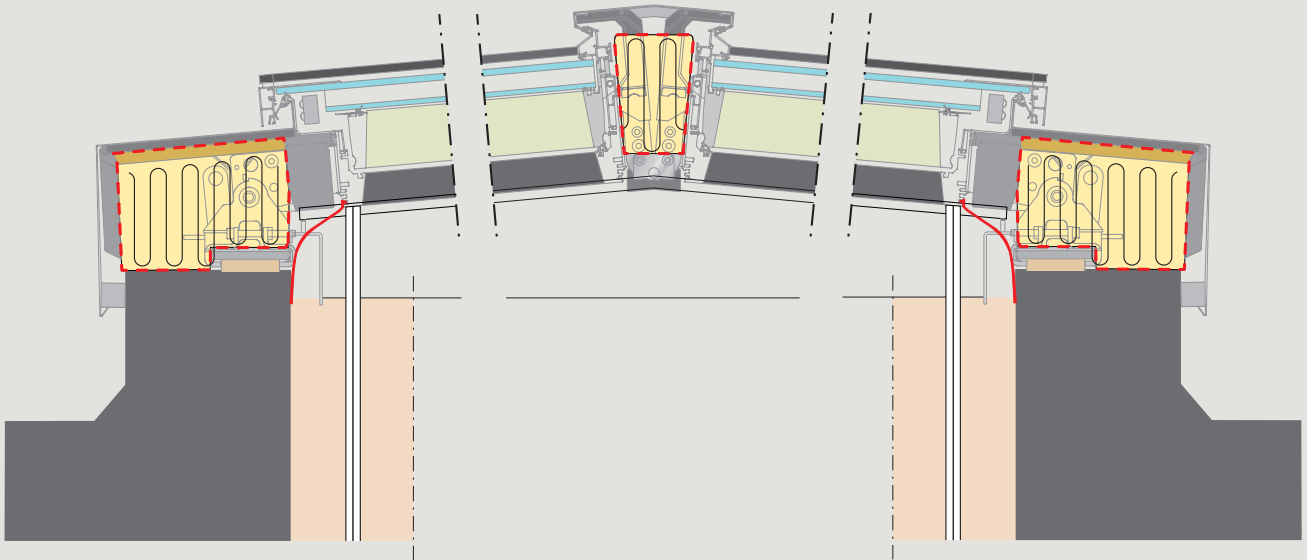
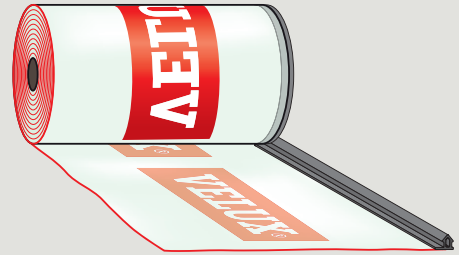

TX 20  
HEX 6

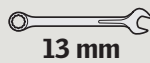

13 mm



HEX 6

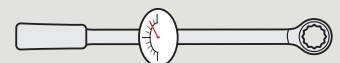
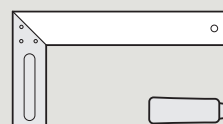

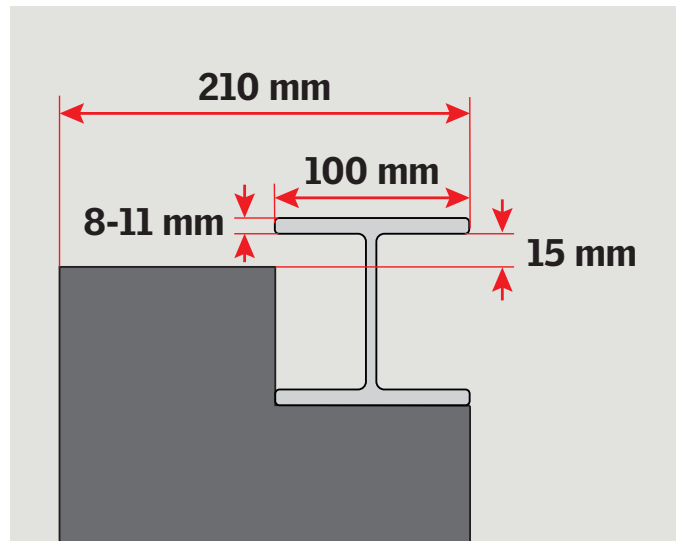
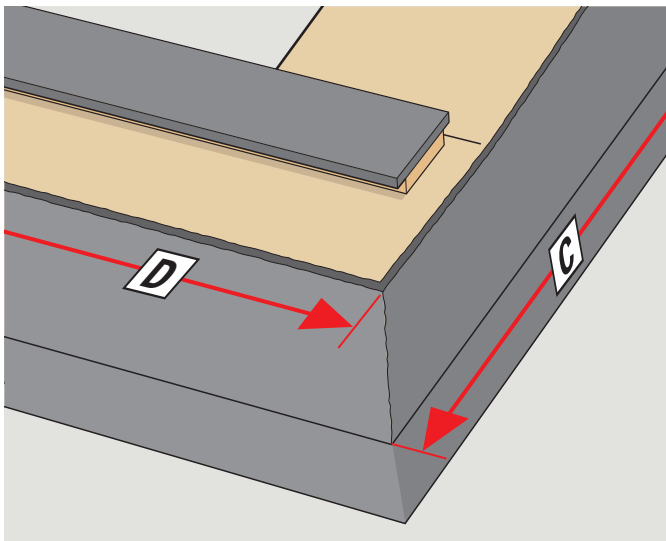
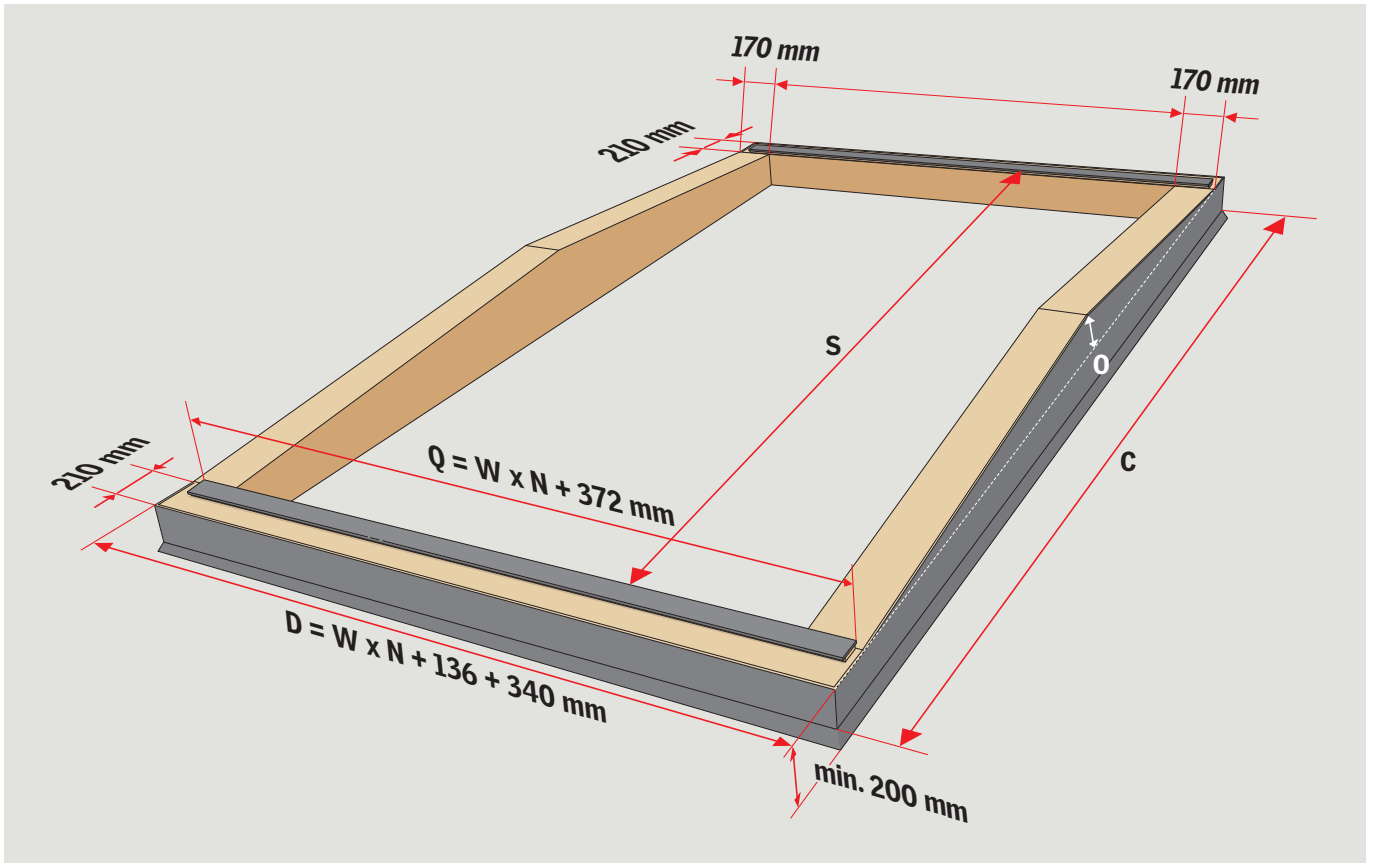

**W mm / H mm / N**

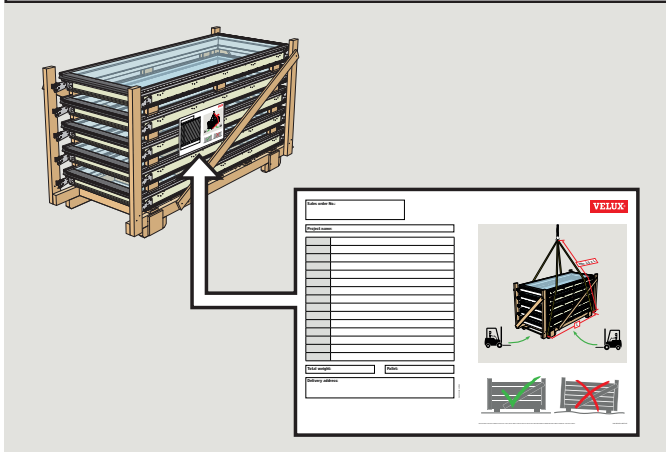

**C mm / D mm / O mm / S mm / Q mm**



1

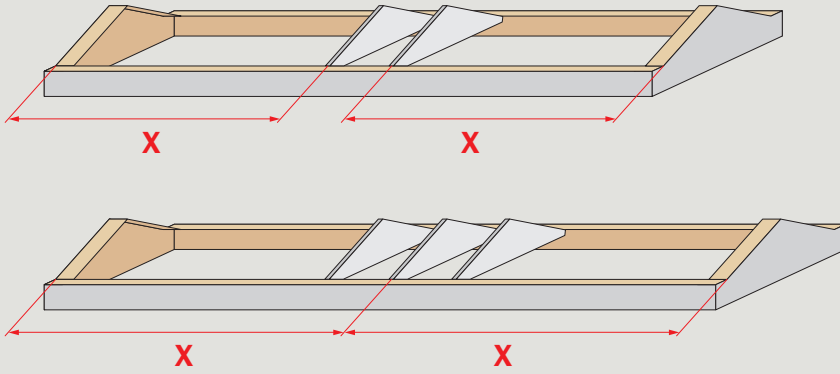
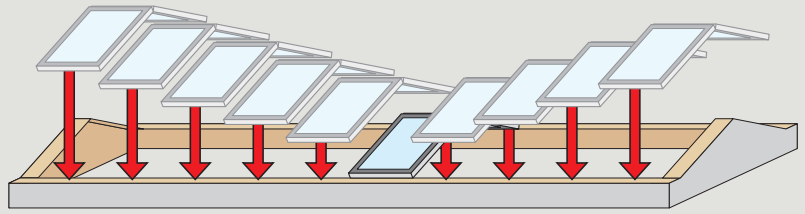

2

A3-R<sub>5°</sub> A5-R<sub>5°</sub>

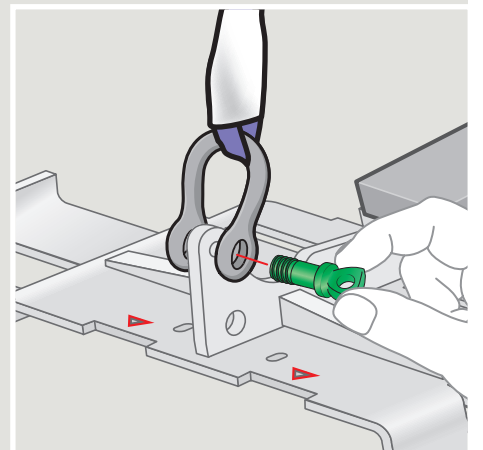
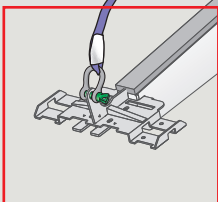
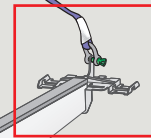
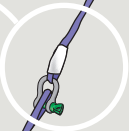
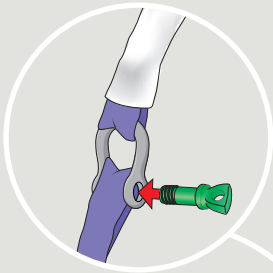

3

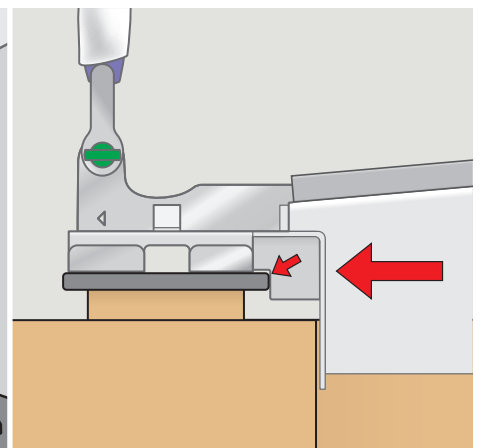
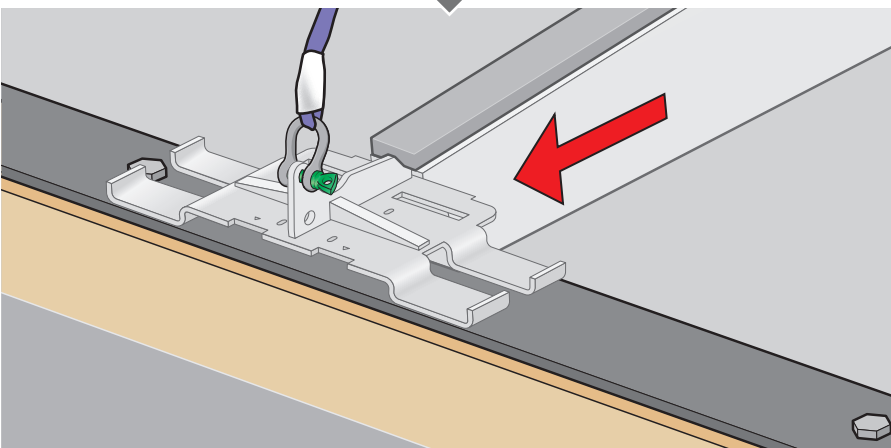
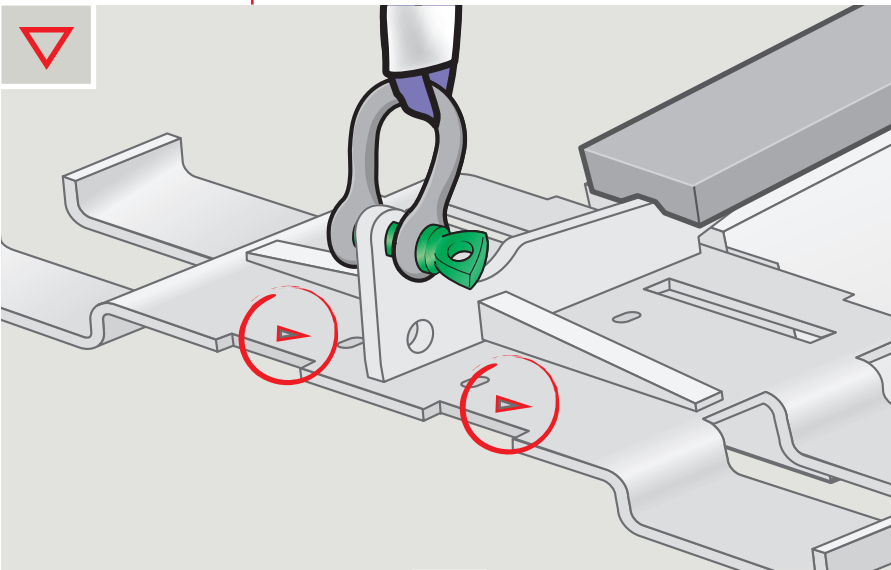
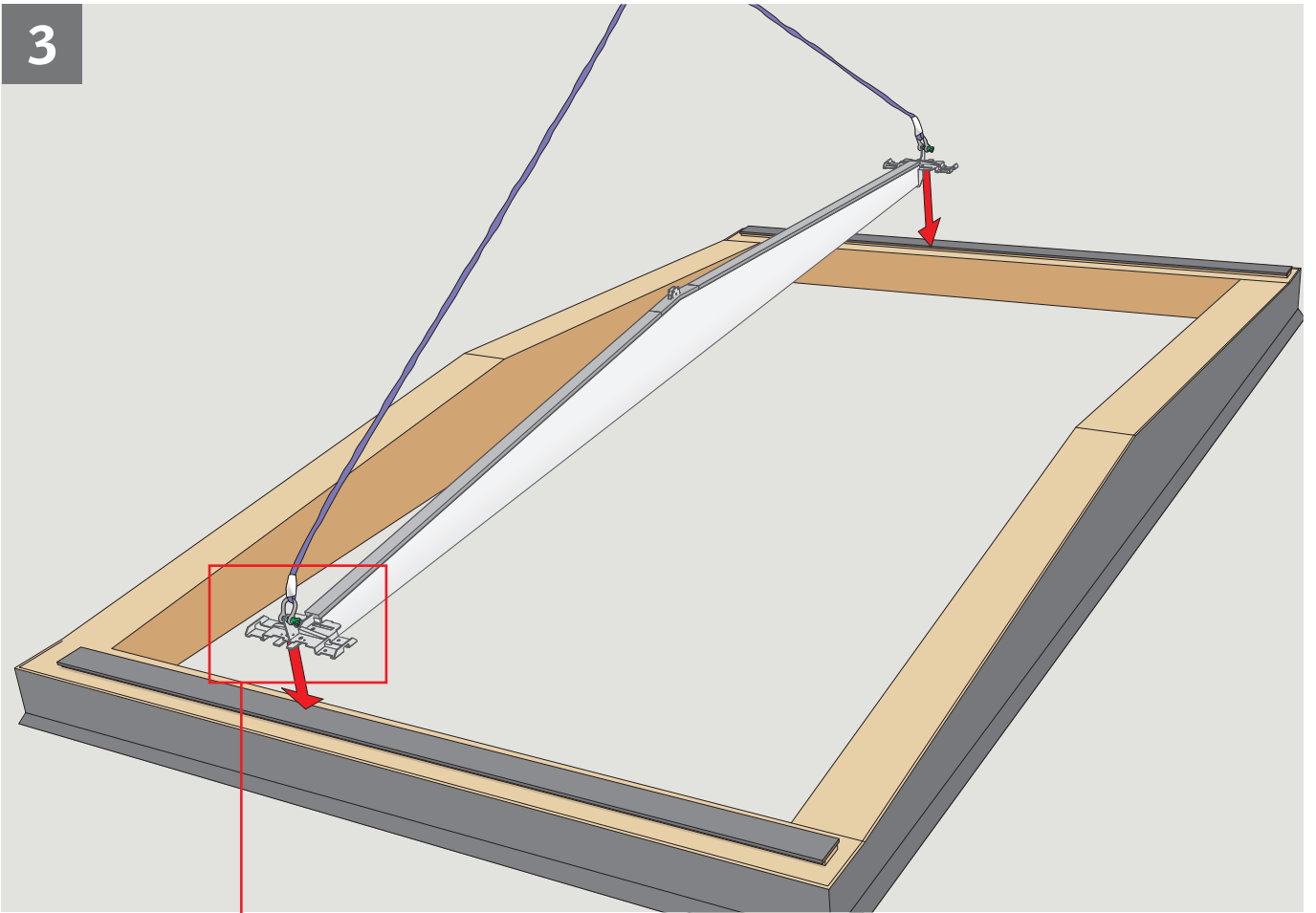

4

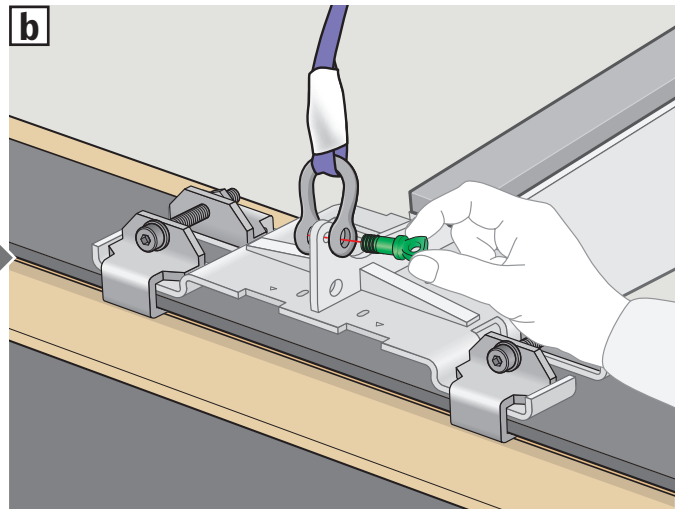
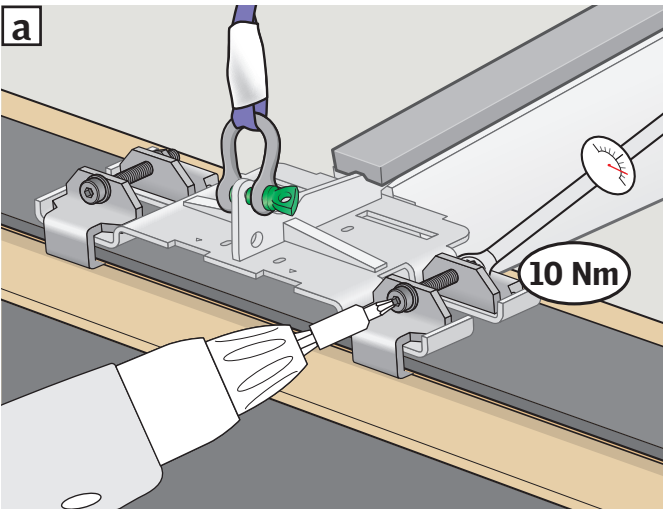
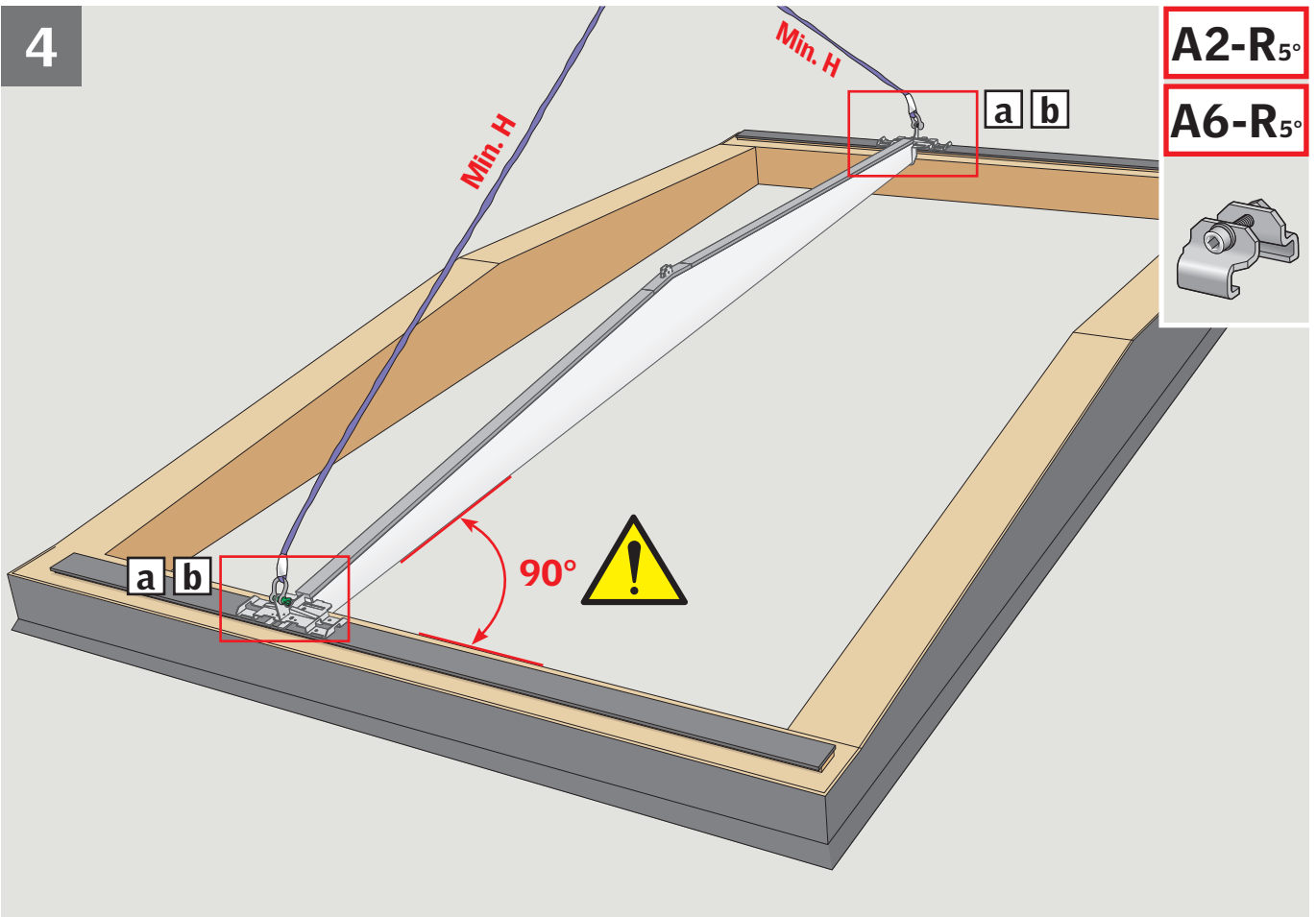



5

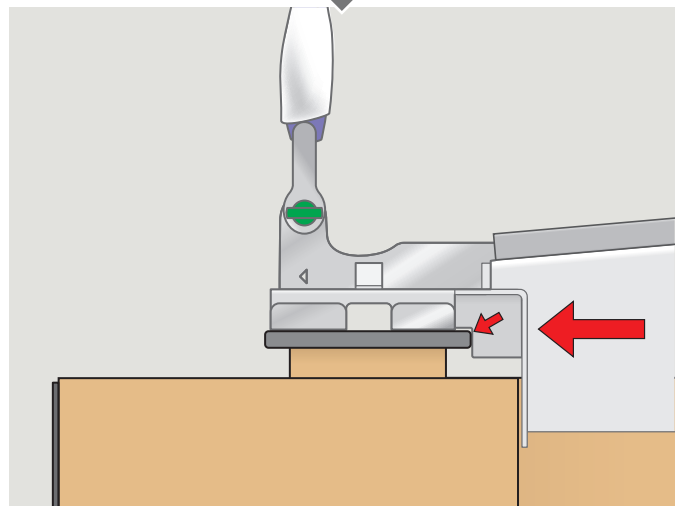
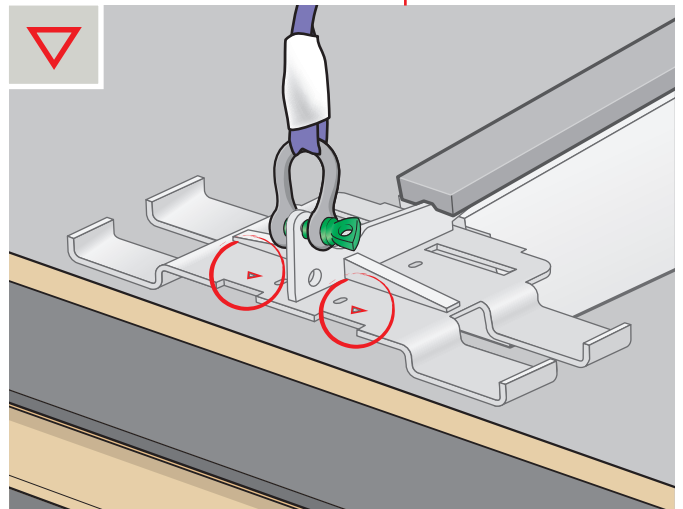
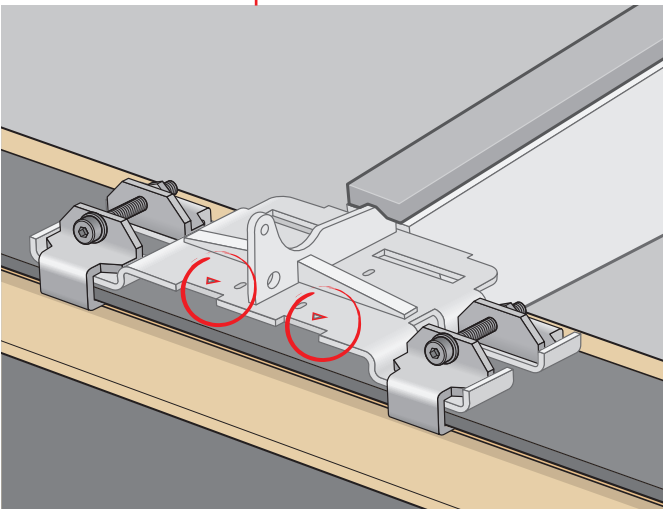
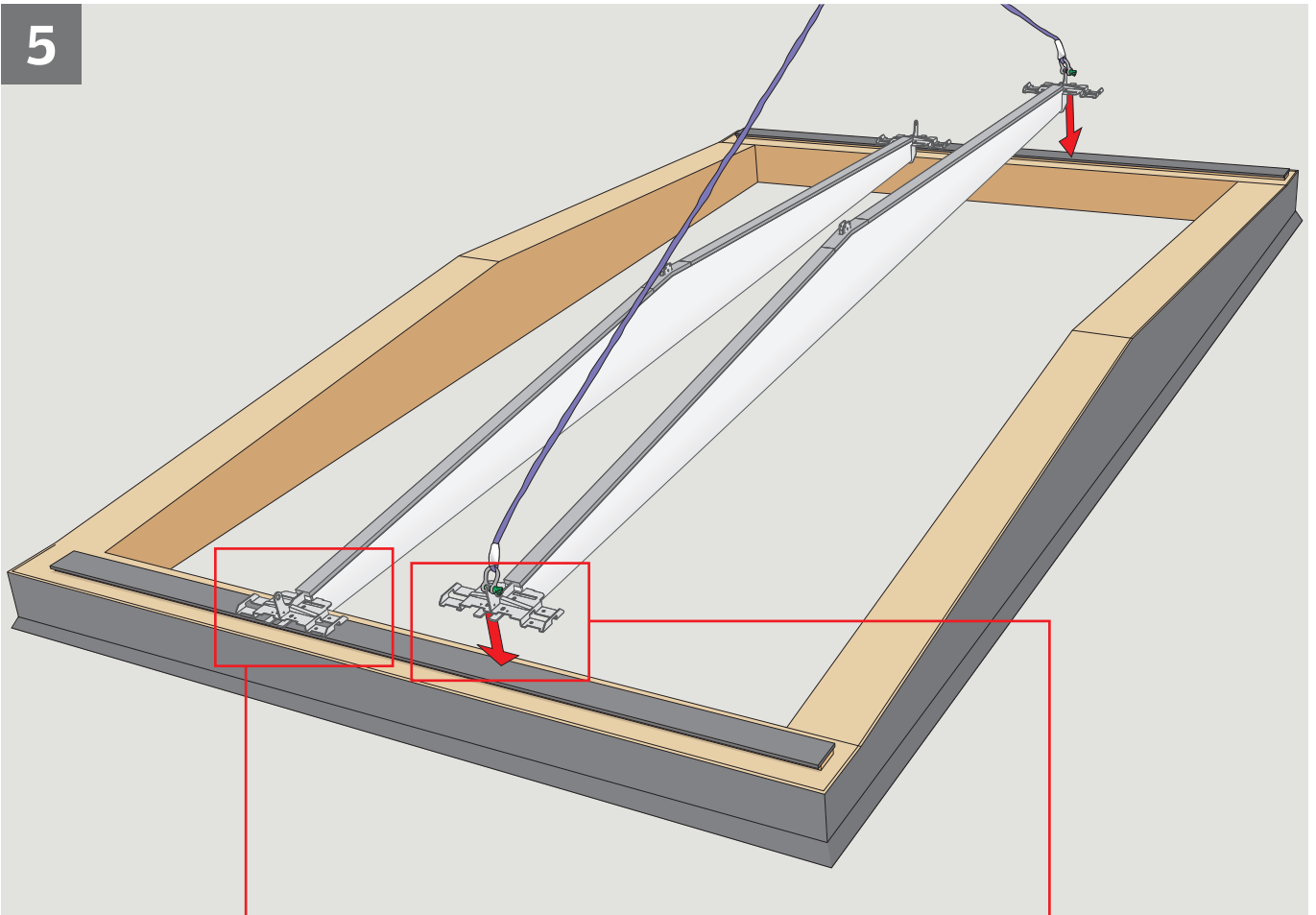

6

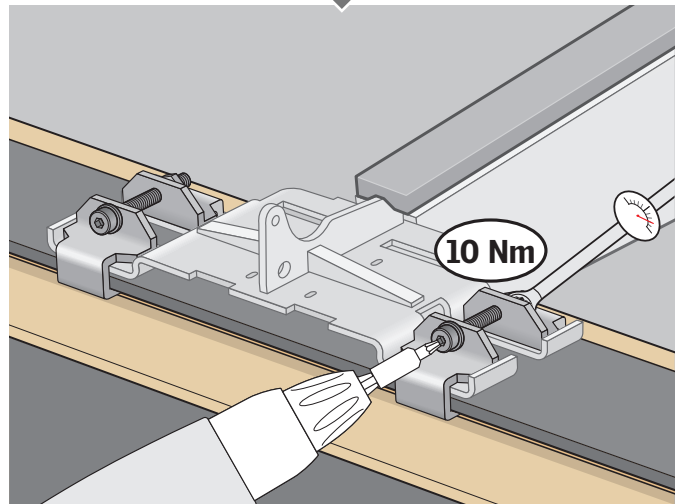
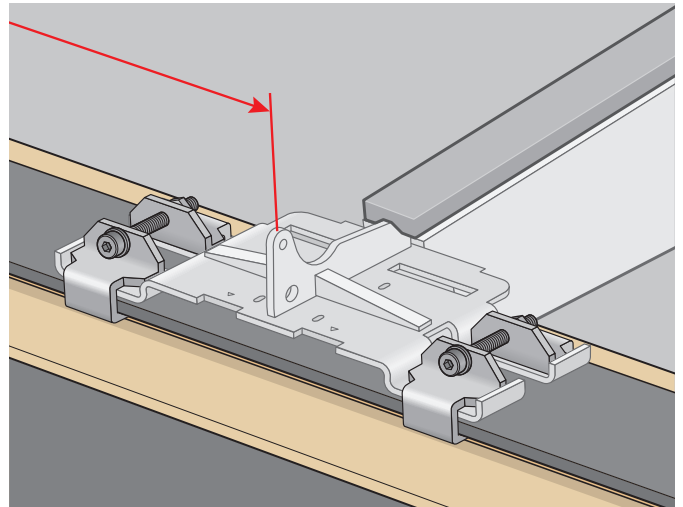
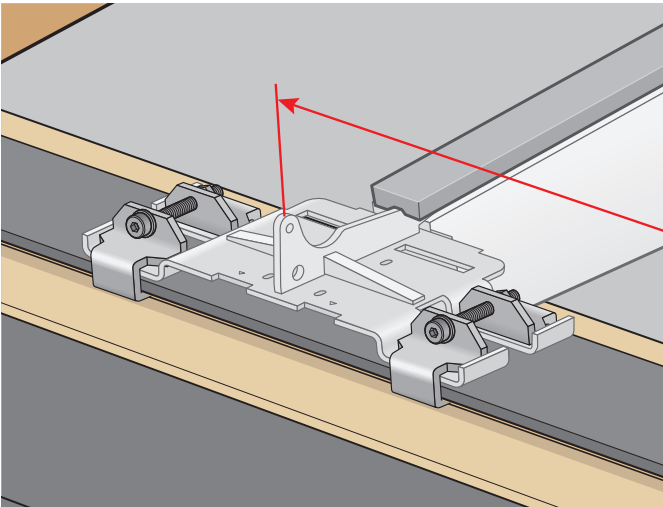
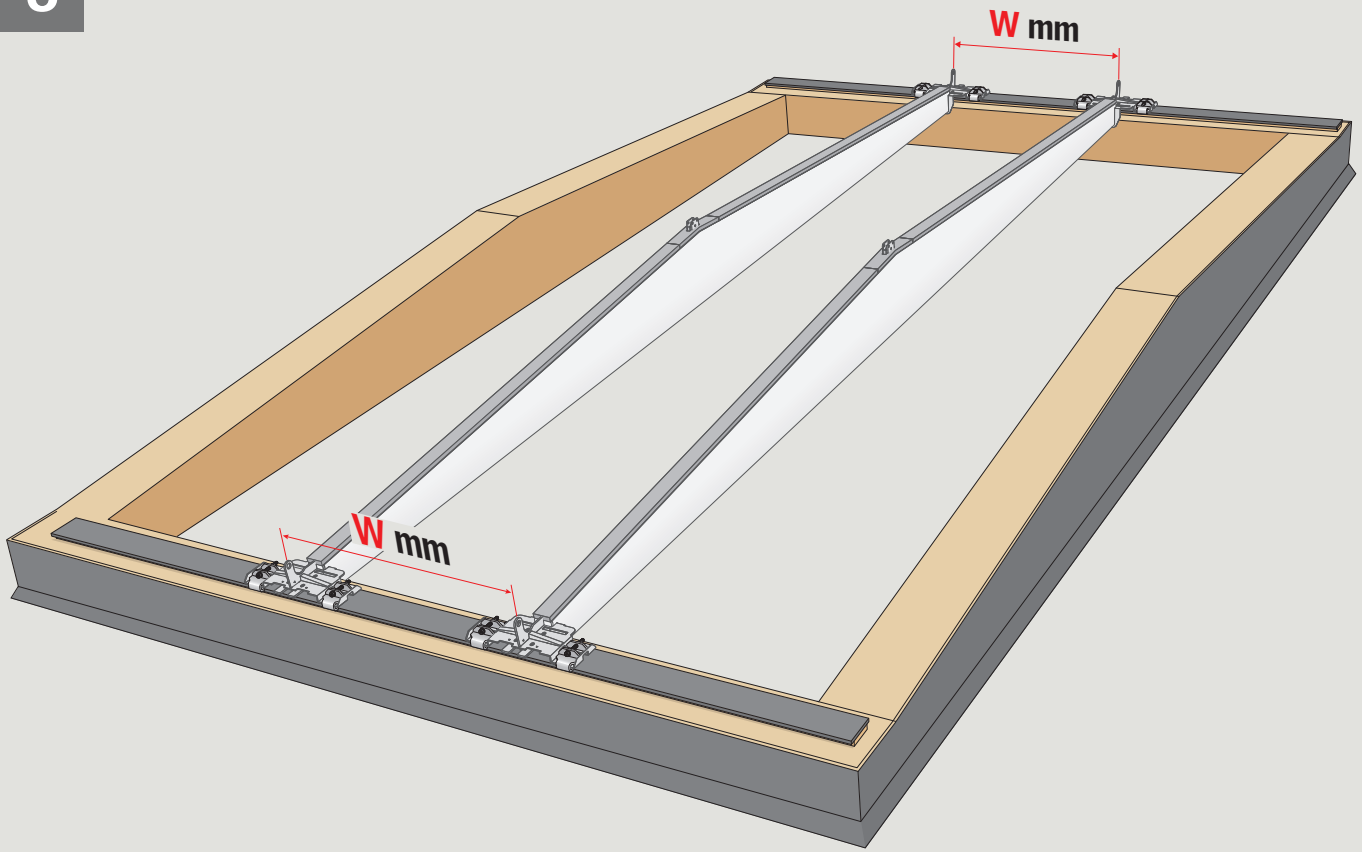

7

A4-R<sub>5</sub>°

A2-R<sub>5</sub>°

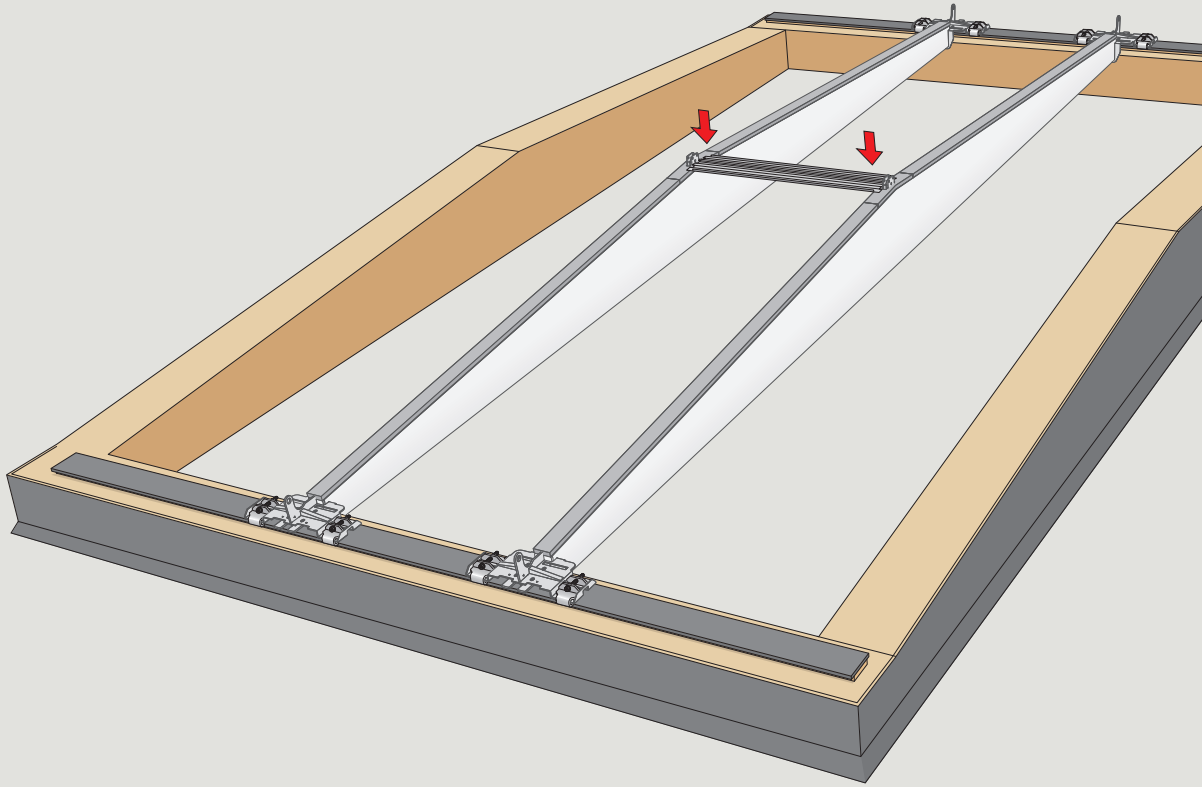

M8 x 10 mm

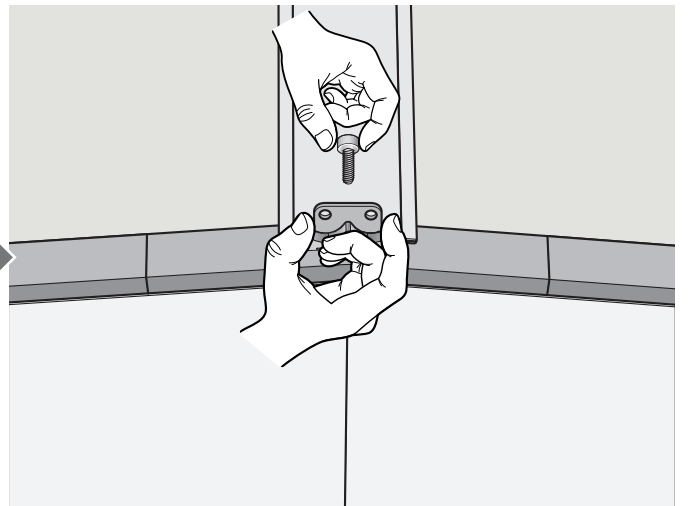
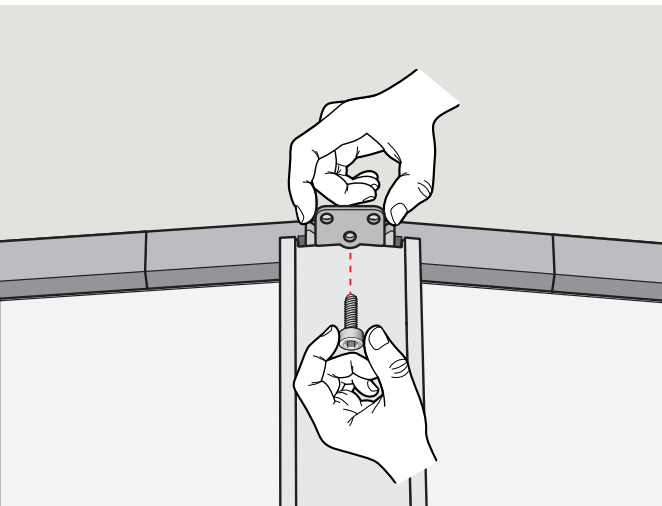
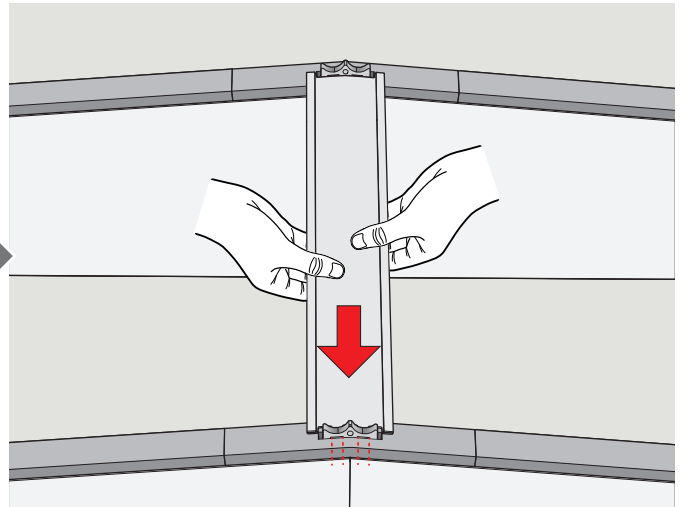
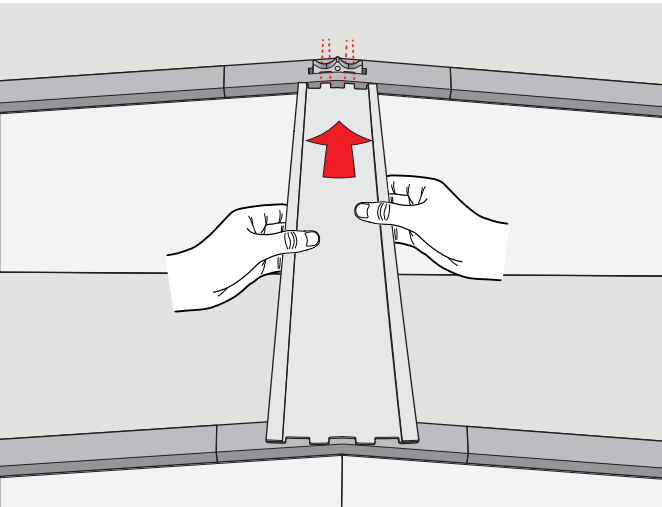
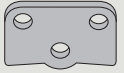

8

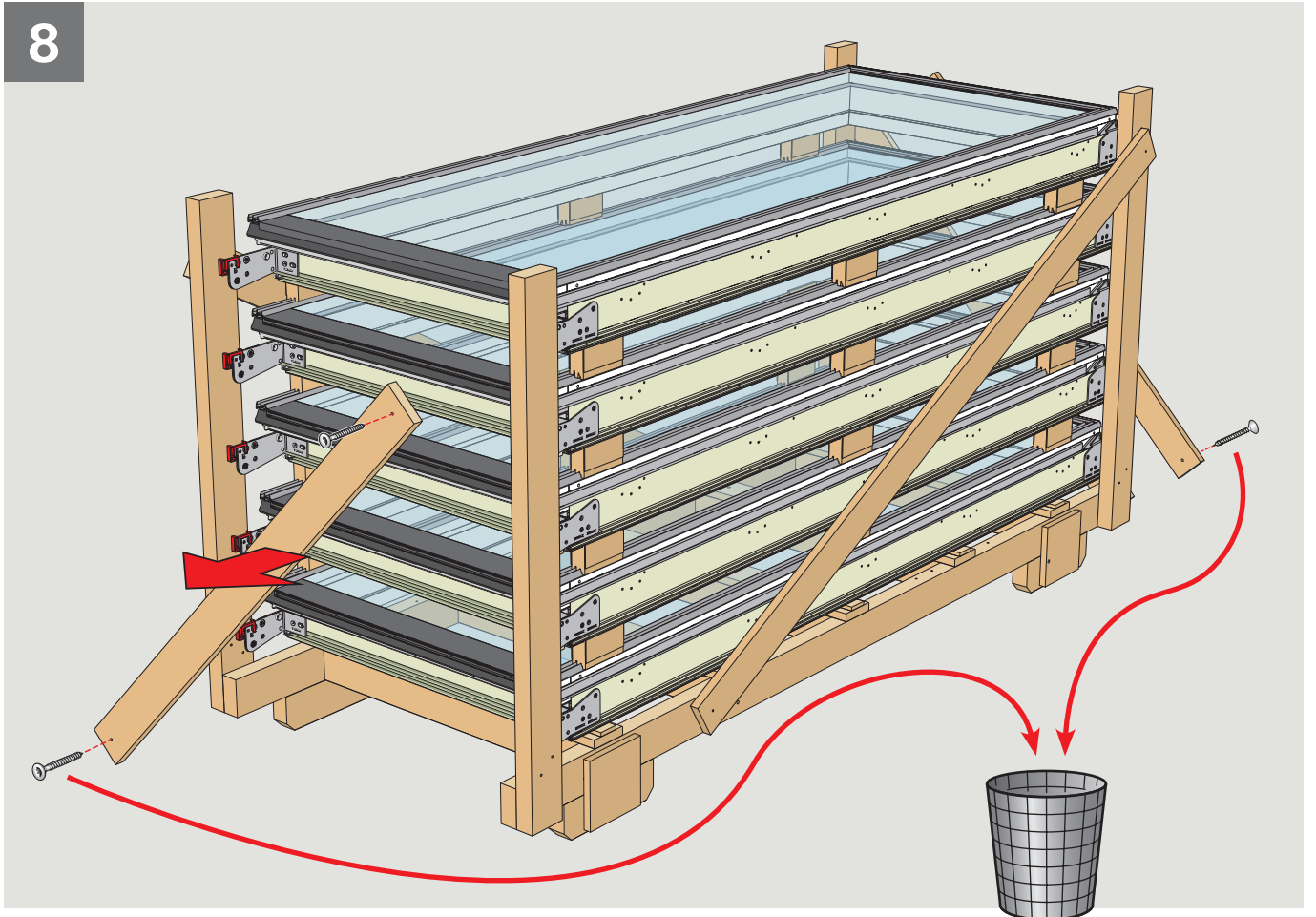

9

A2-R5°

34

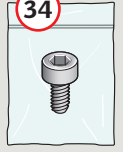

M8 x 10 mm

35



∅ 8 mm

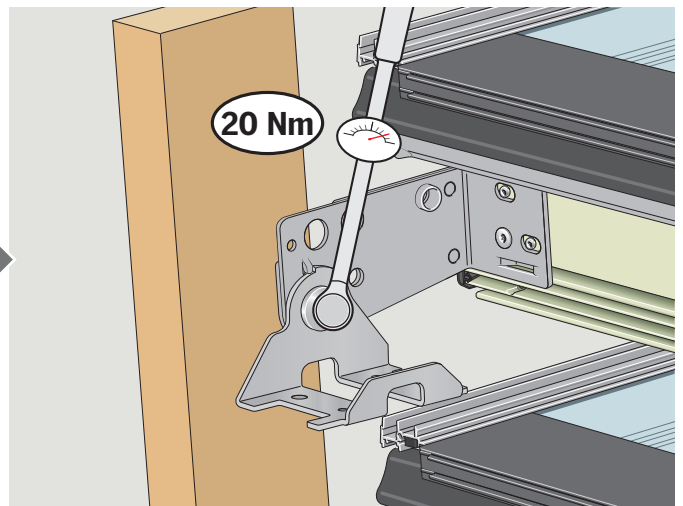
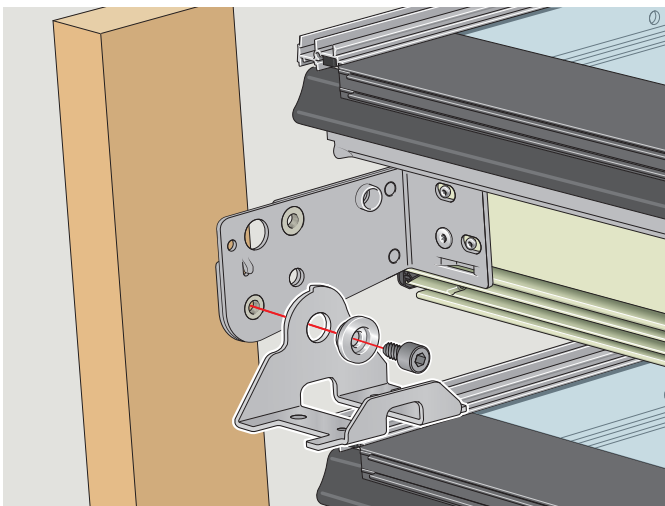
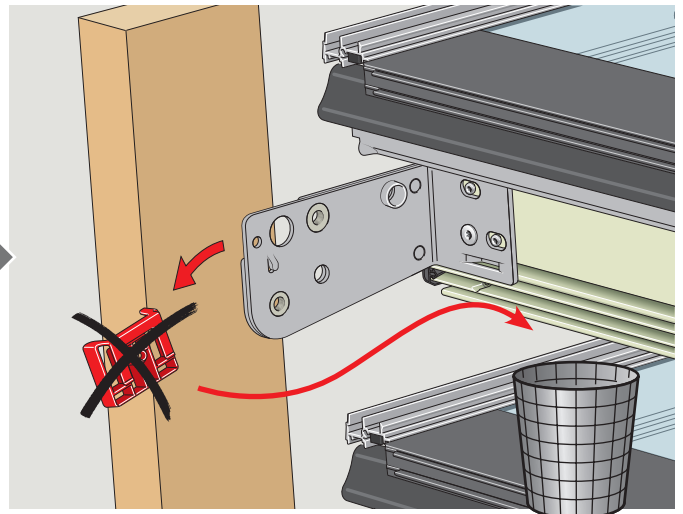
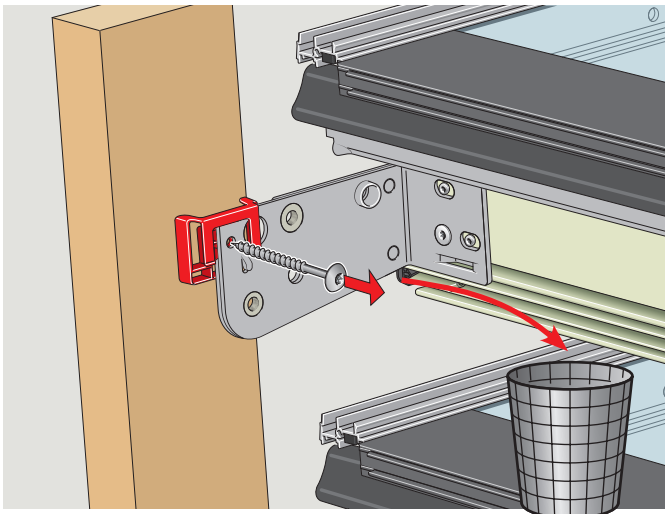
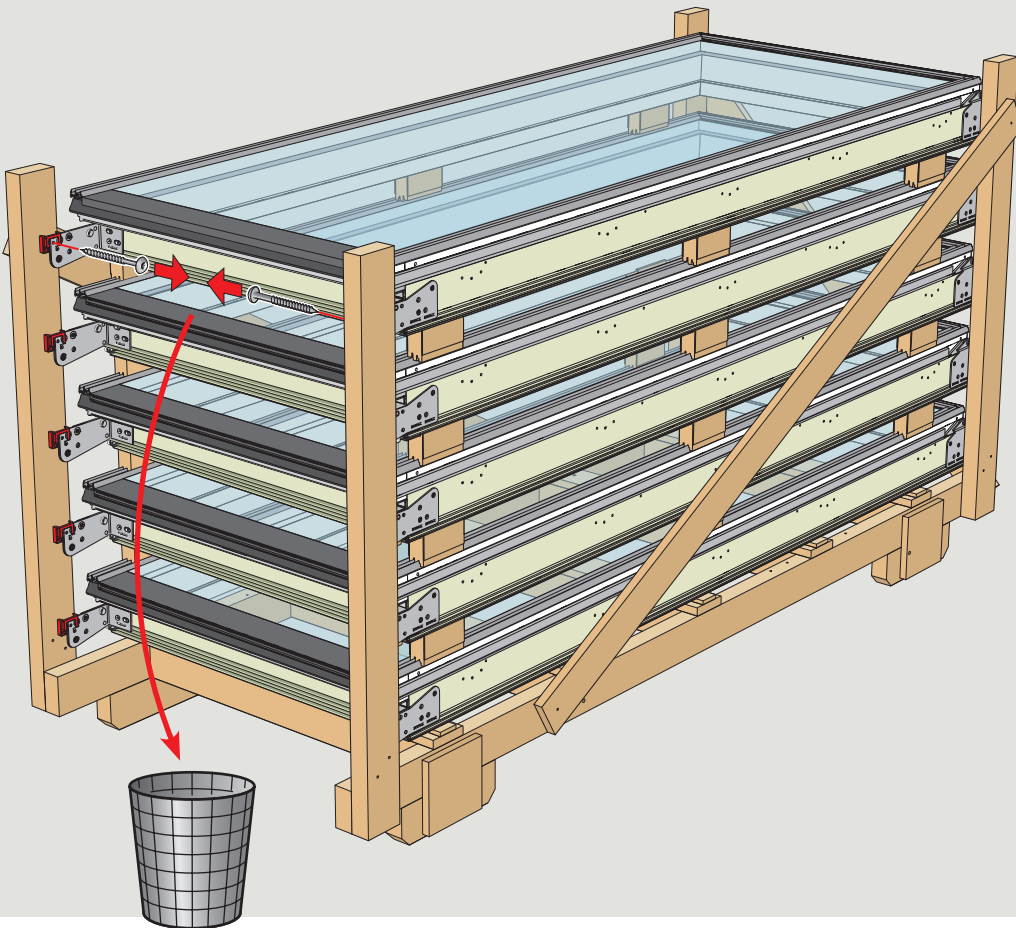
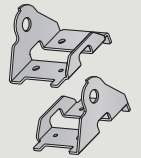

10

A2-R5°

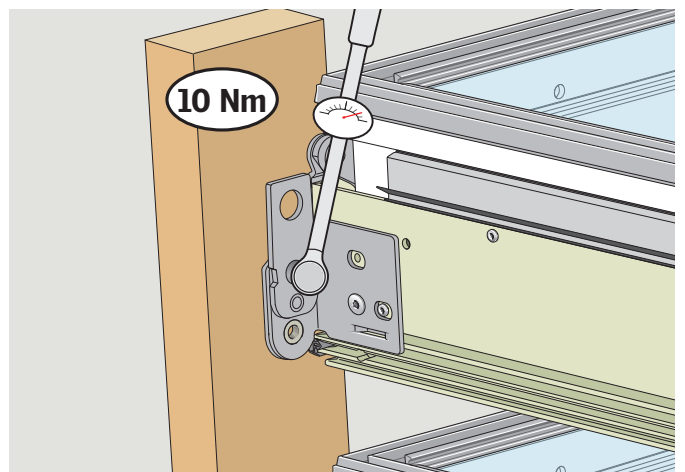
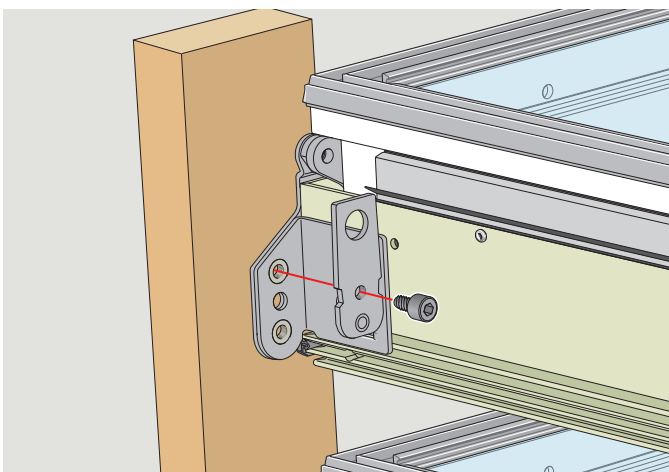
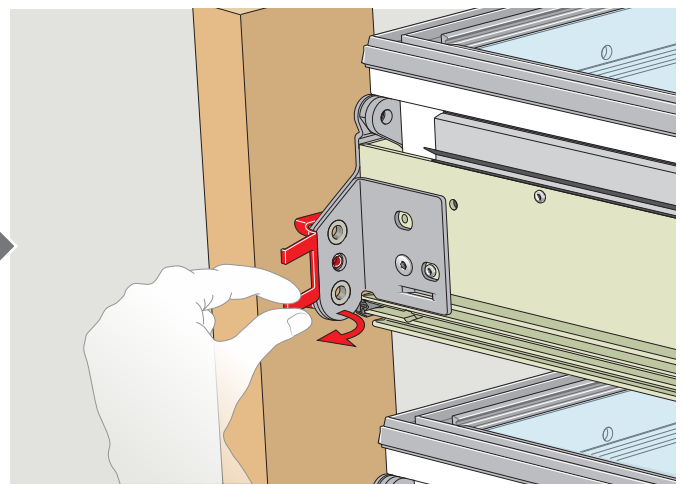
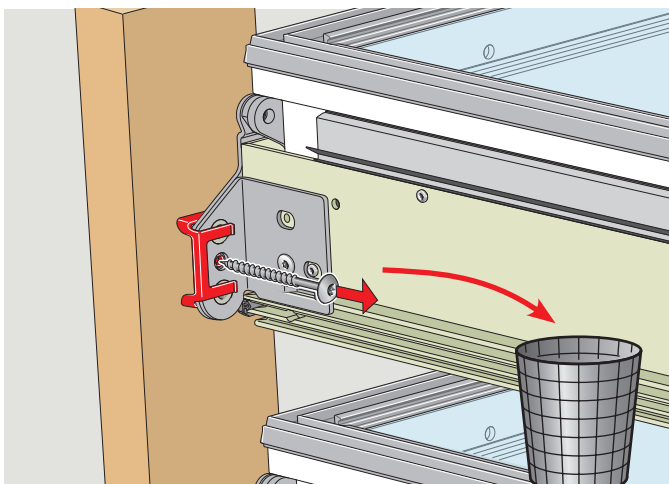
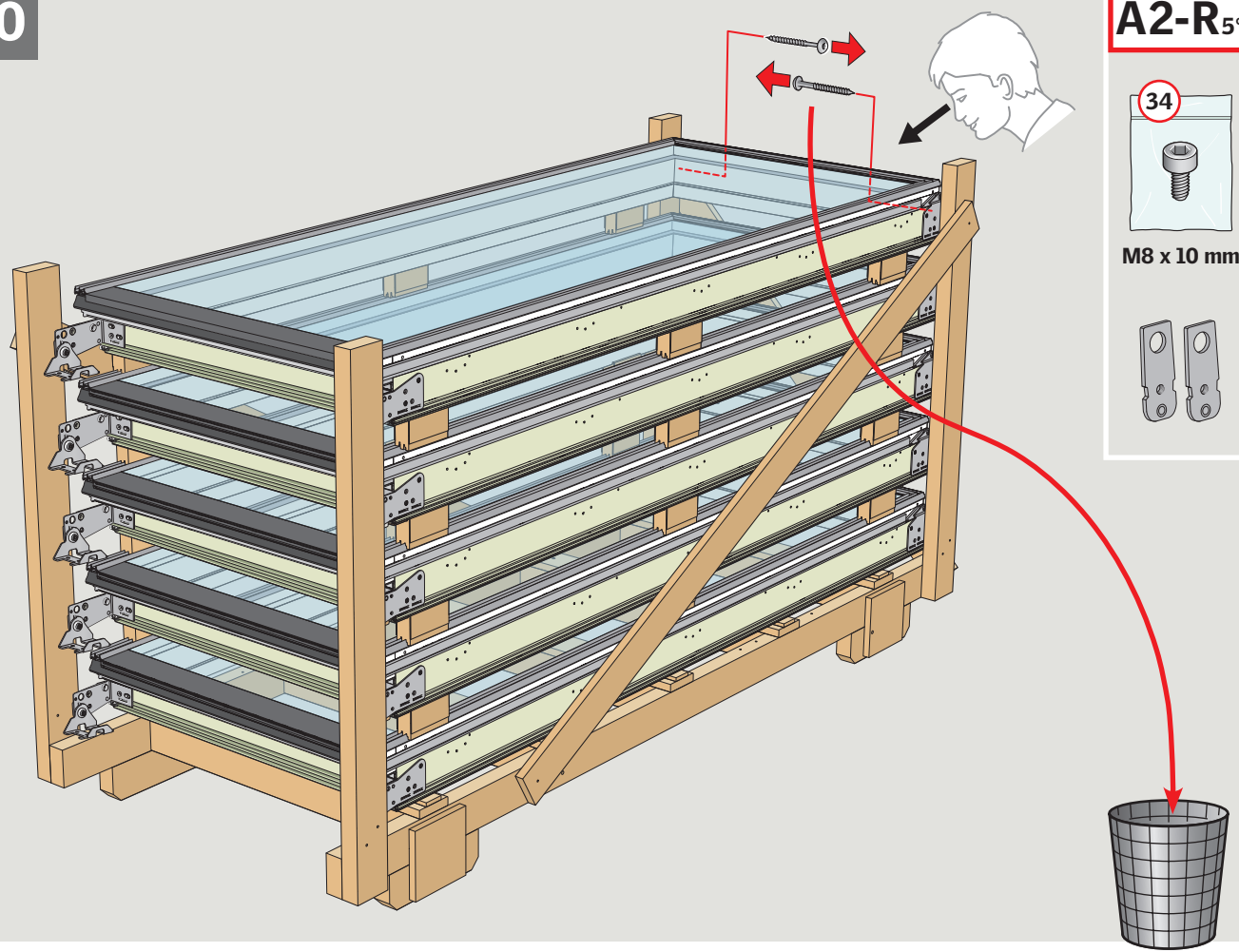

11

A3-R<sub>5</sub>°

WLL 220 kg /  
4x55 kg (SF4)

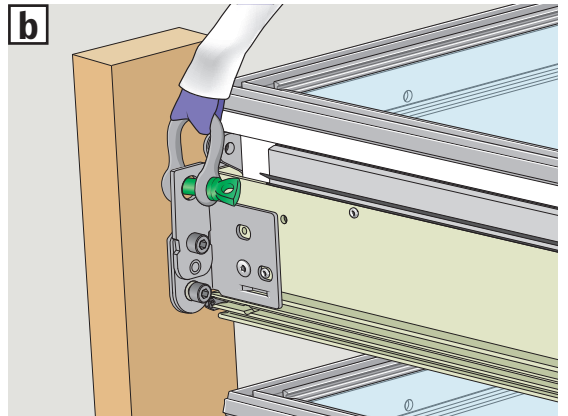
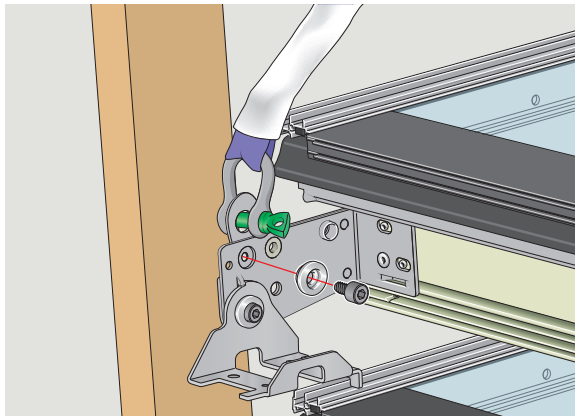
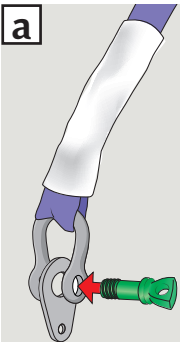
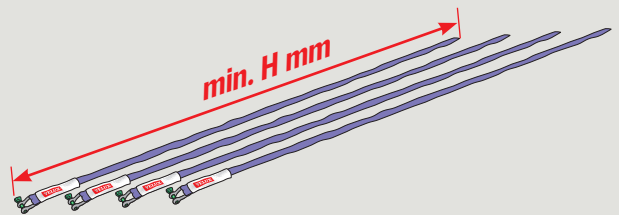
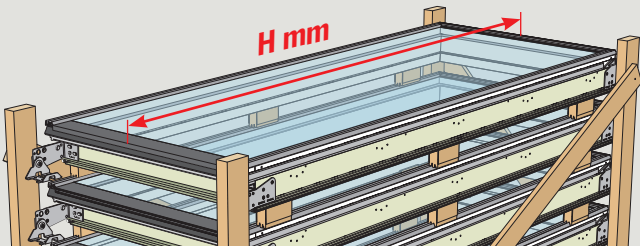
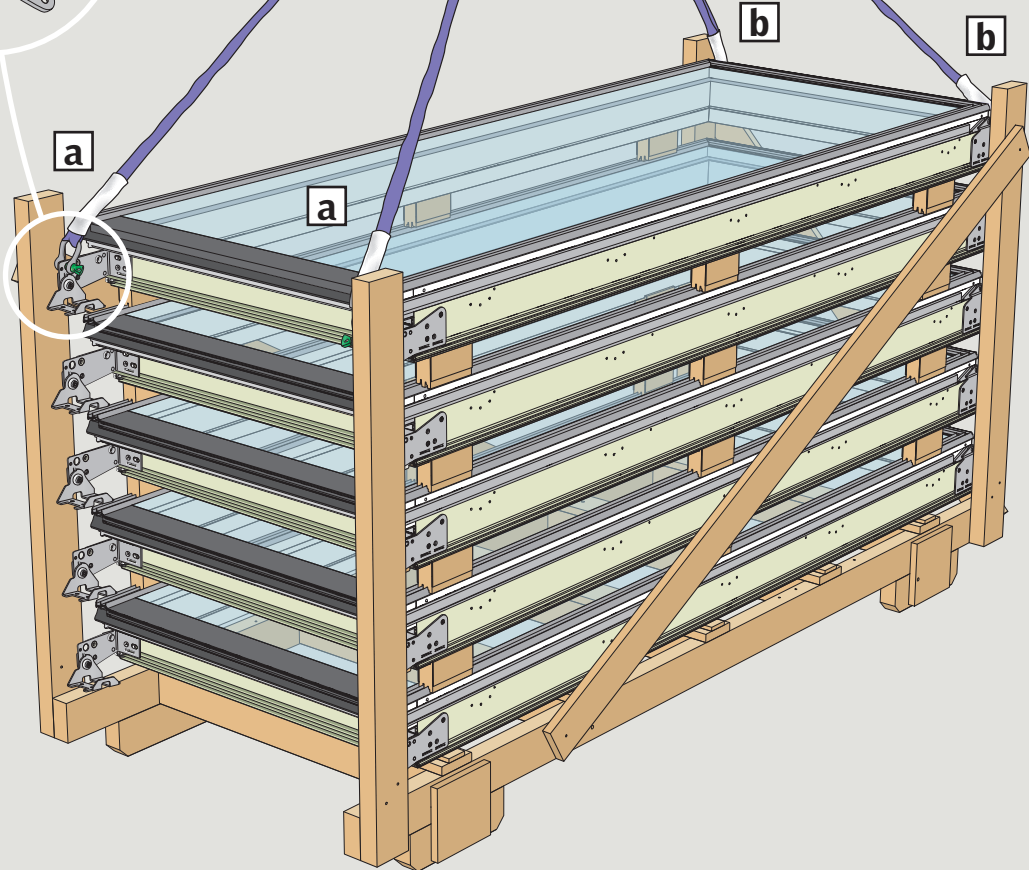
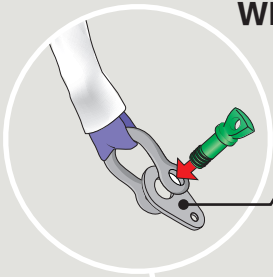

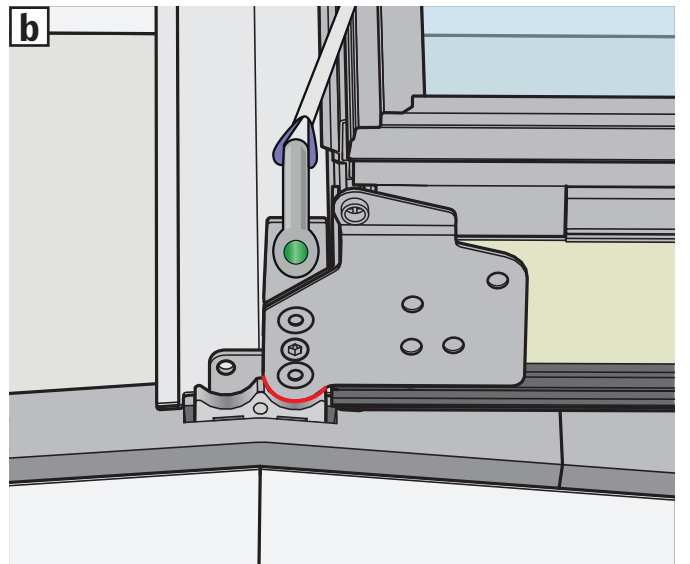
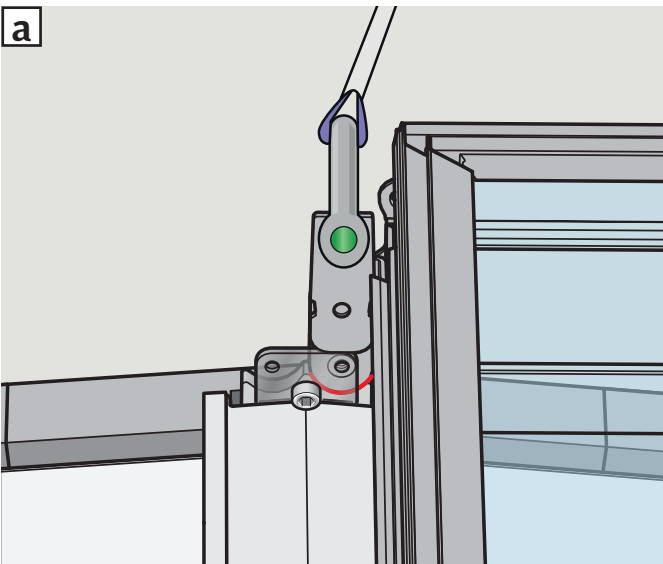
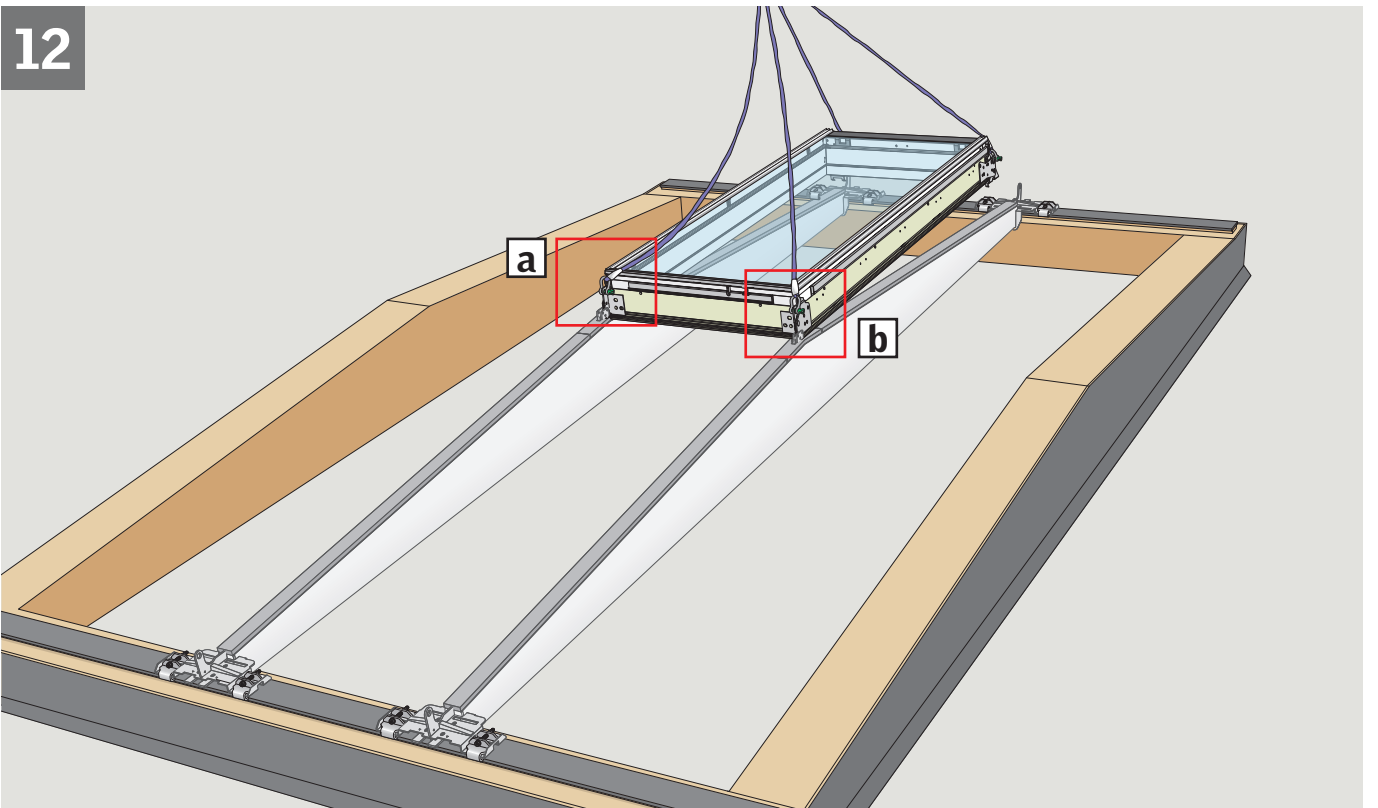
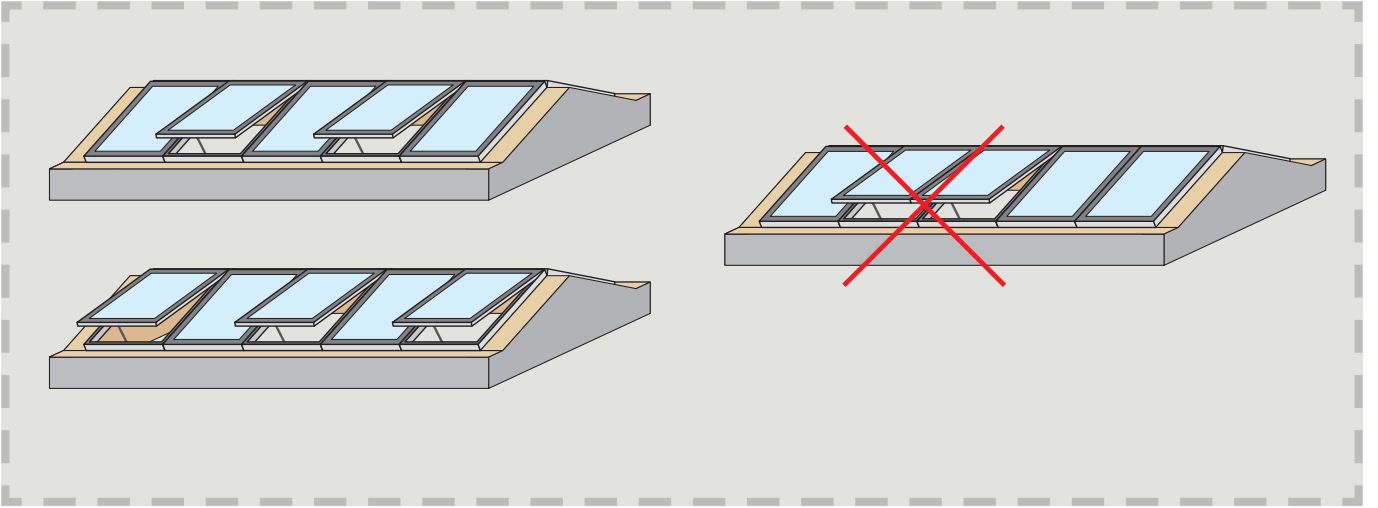



13

A2-R5°

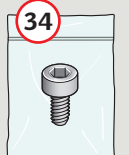
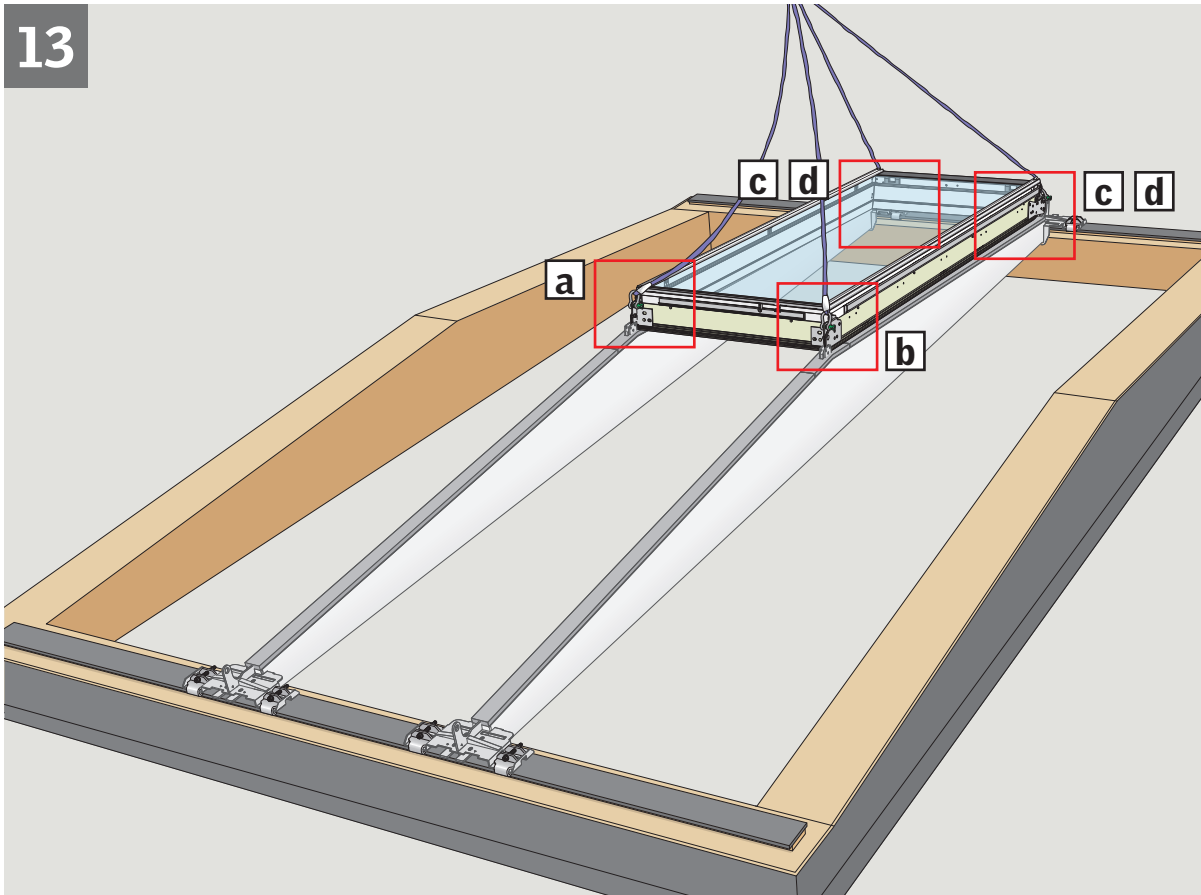

M8 x 10 mm



Ø 8 mm

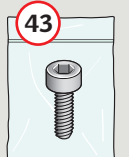

M8 x 20 mm

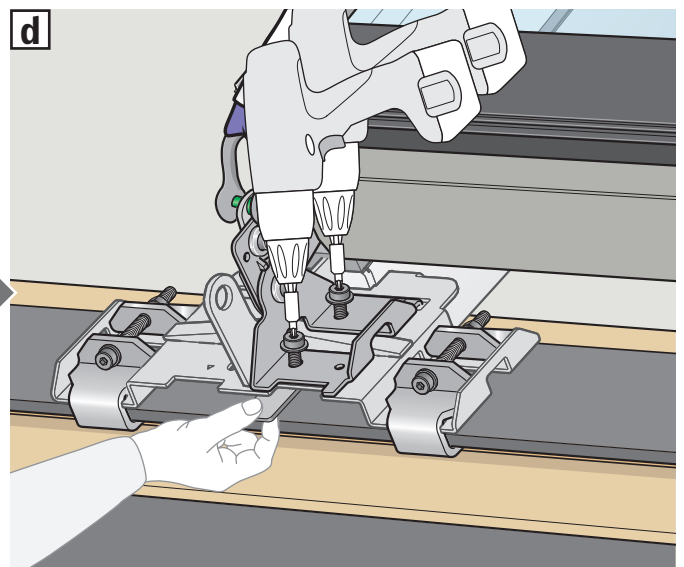
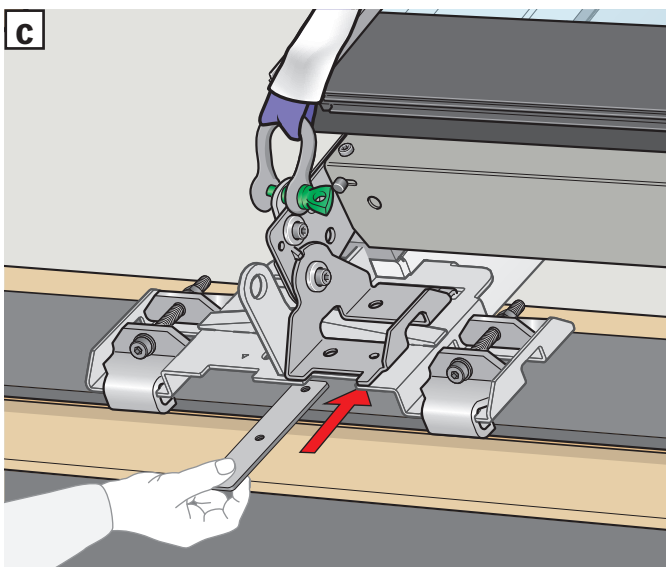
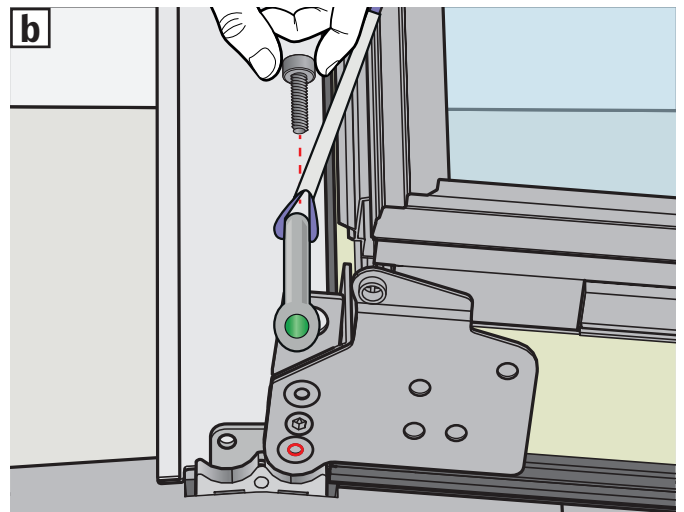
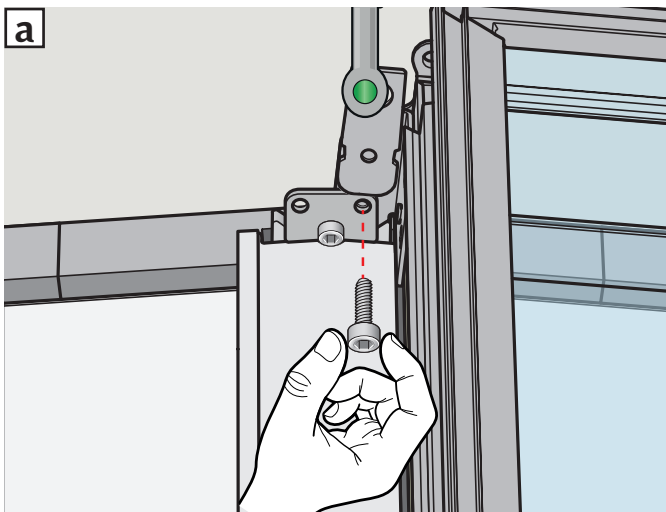

14

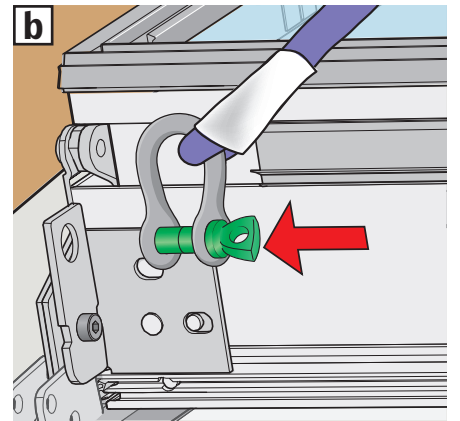
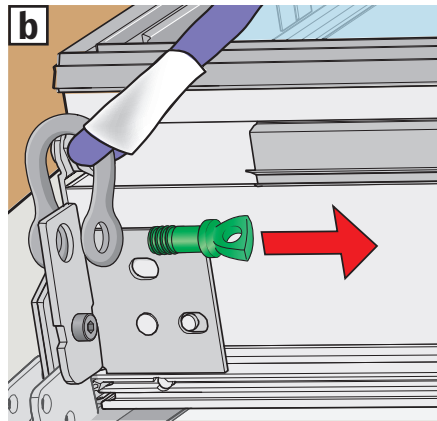
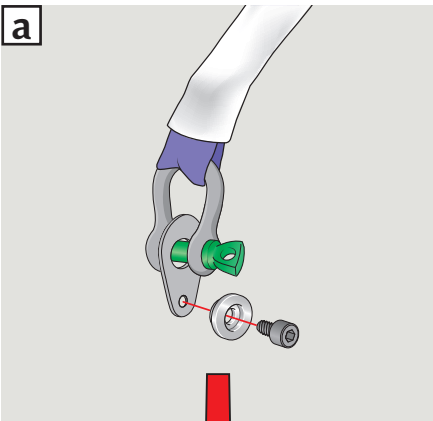
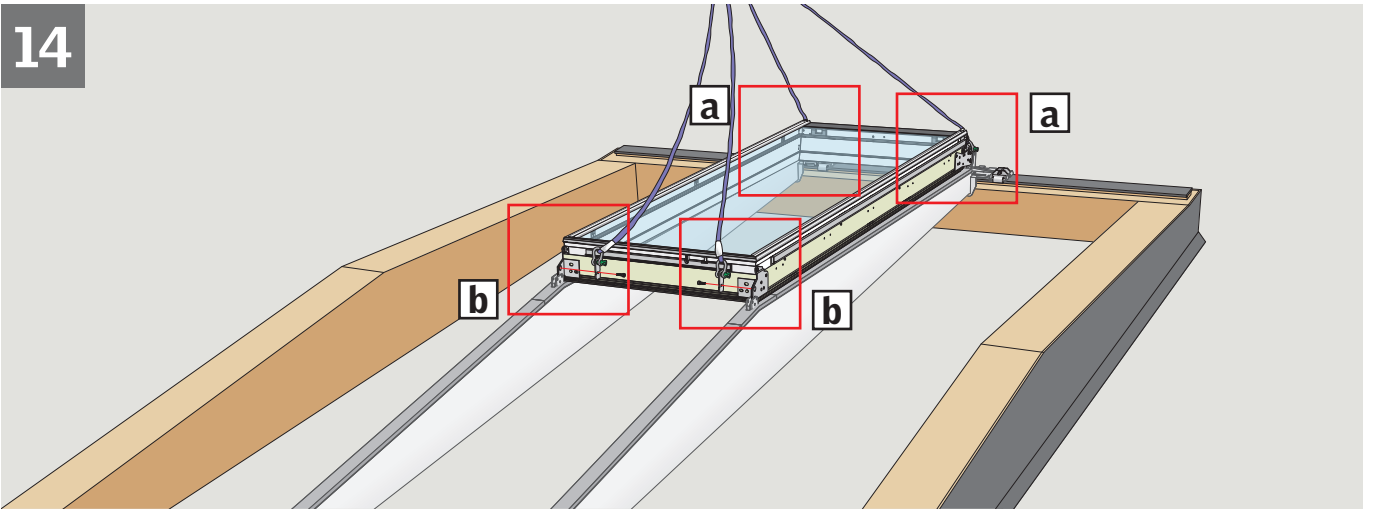

15

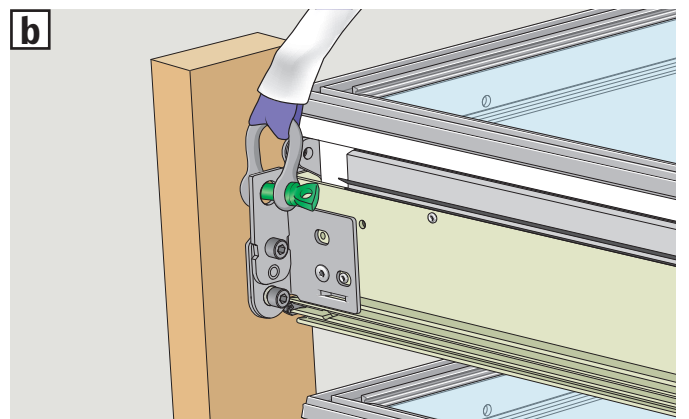
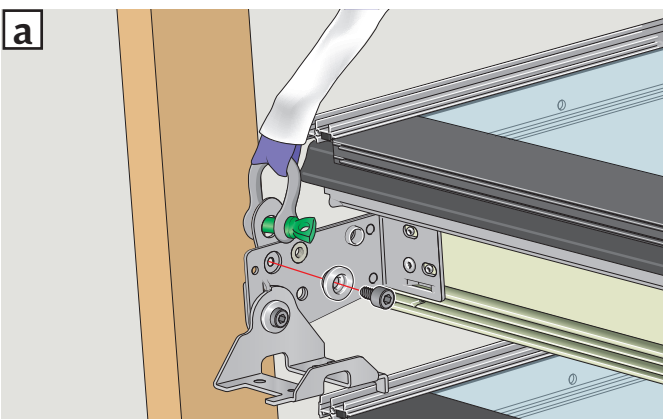
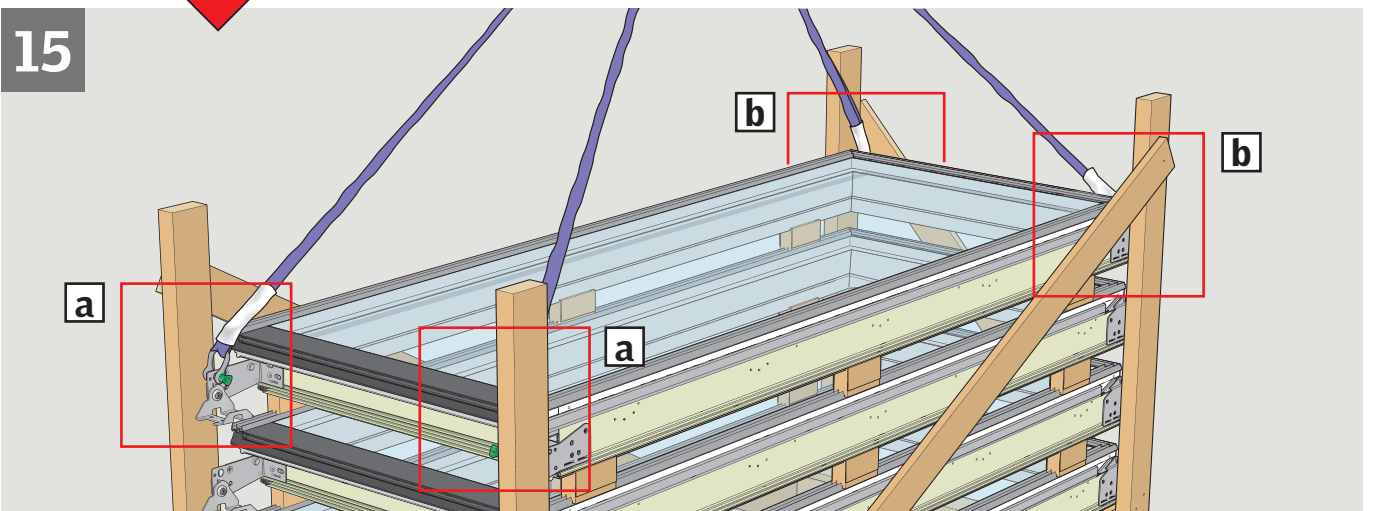

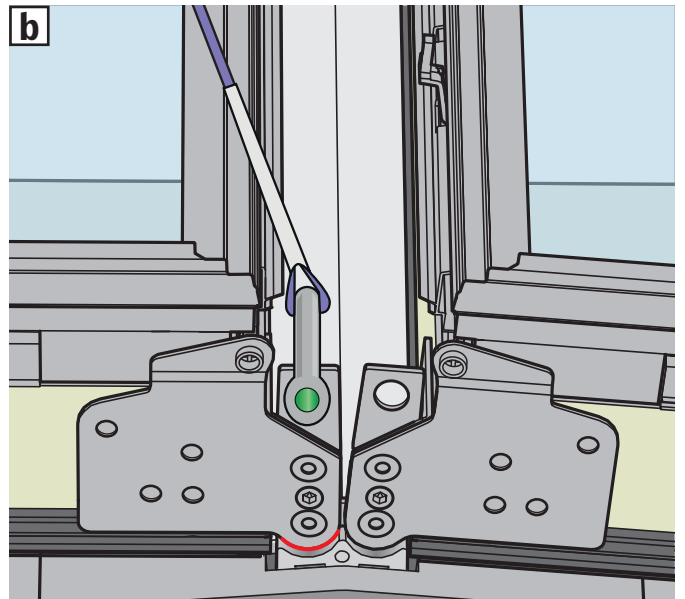
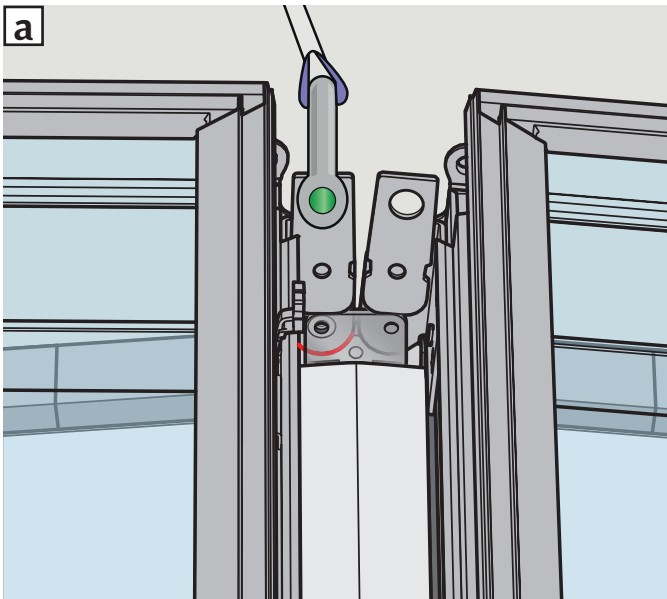
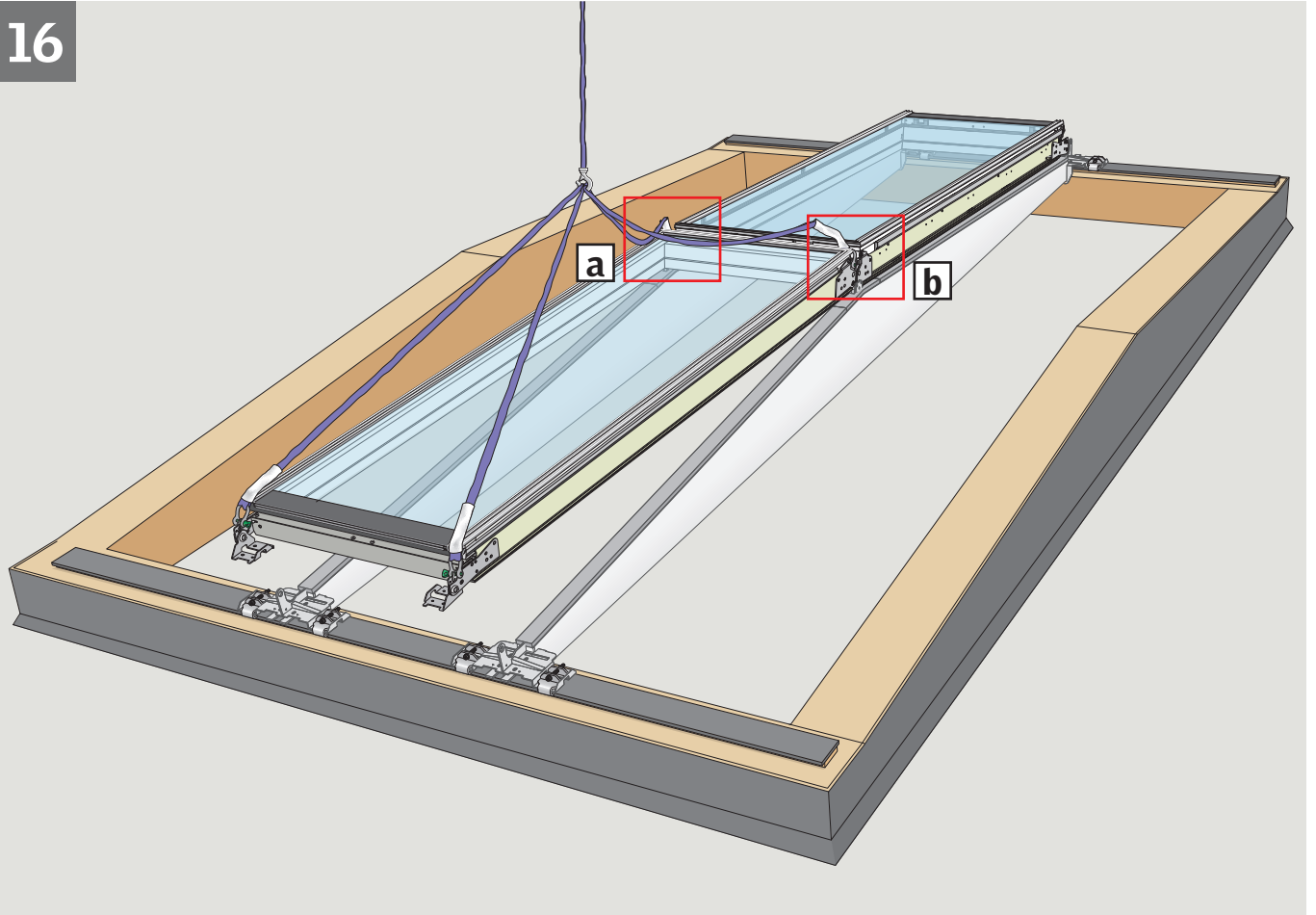

17

A2-R<sub>5°</sub>

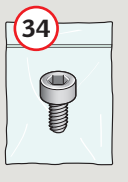

M8 x 10 mm

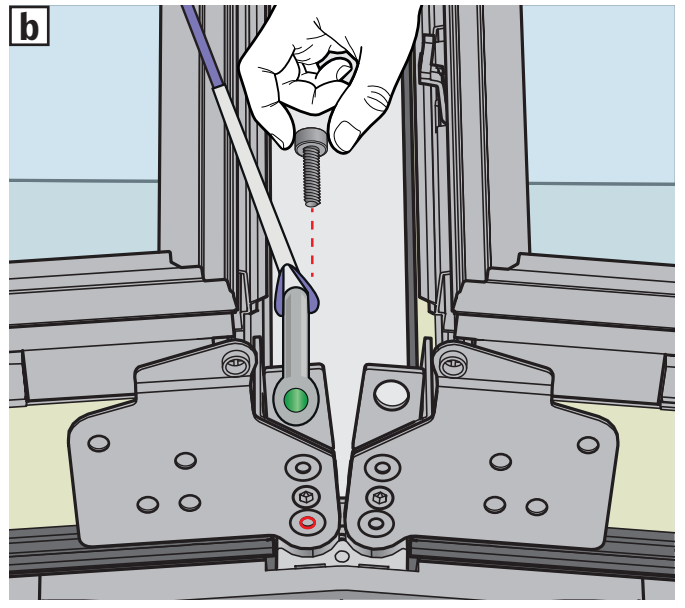
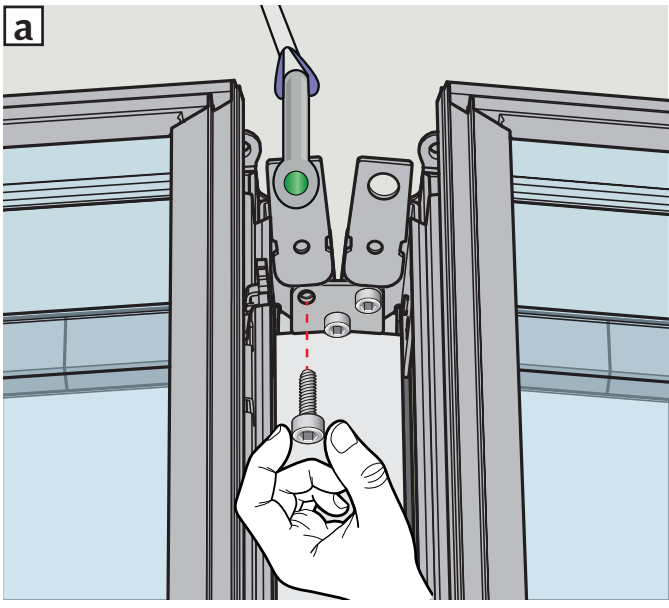
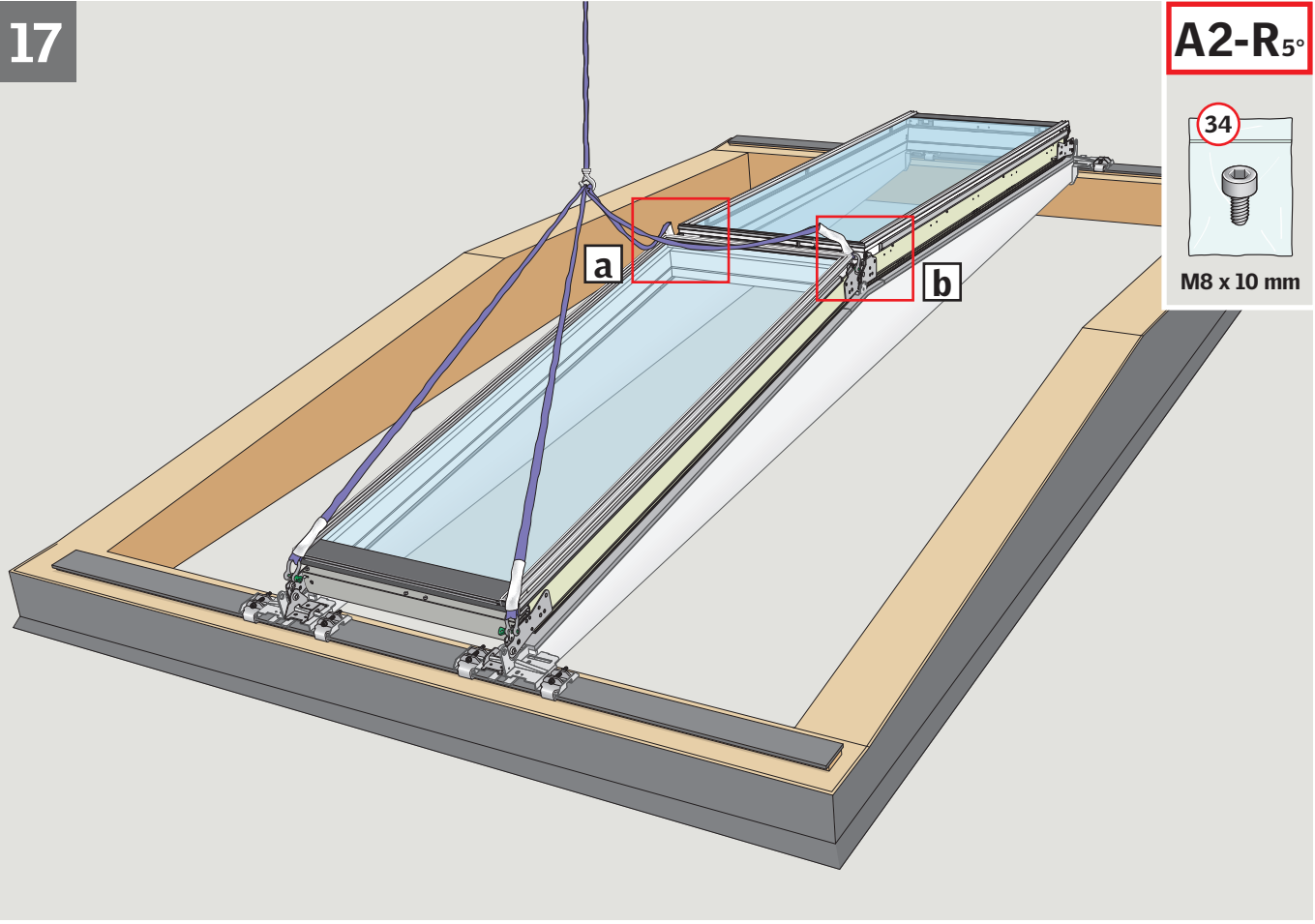

18

A2-R<sub>5°</sub>

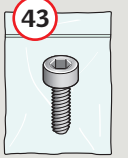
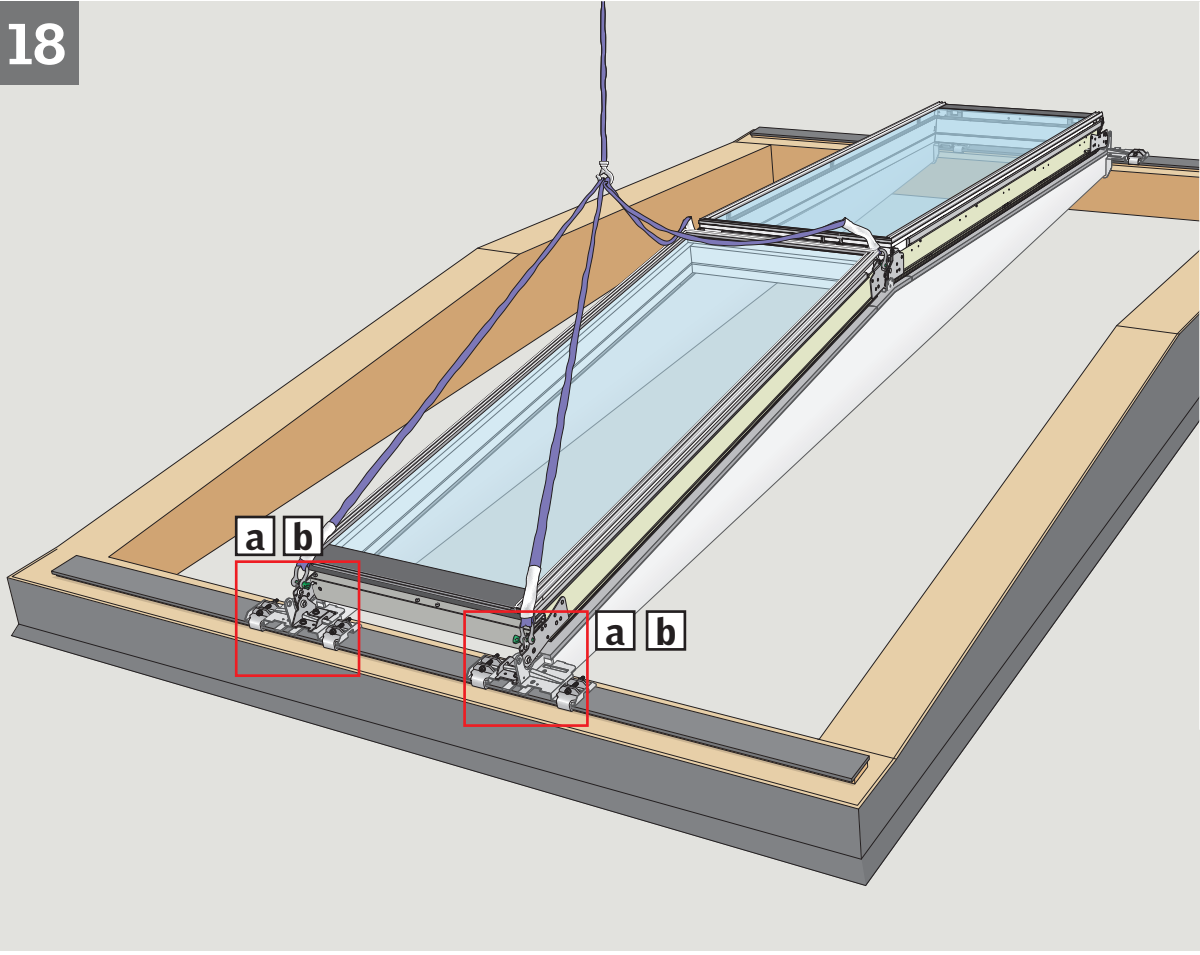

M8 x 20 mm

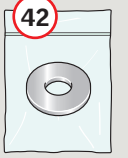

M8

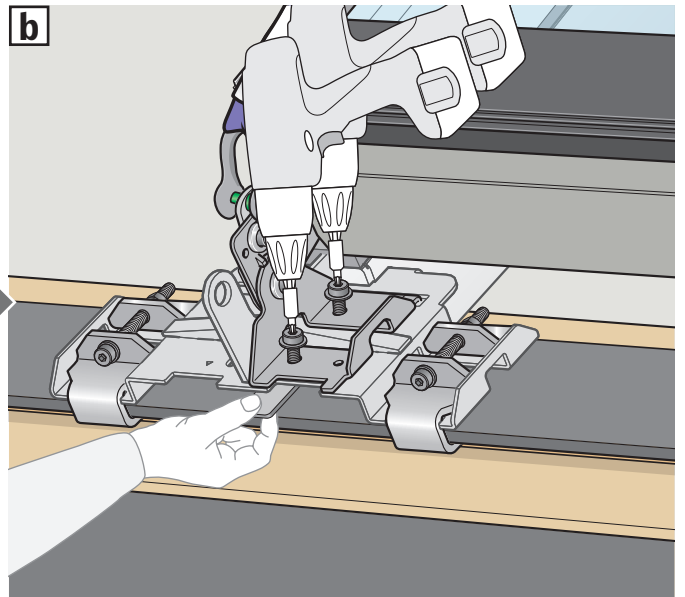
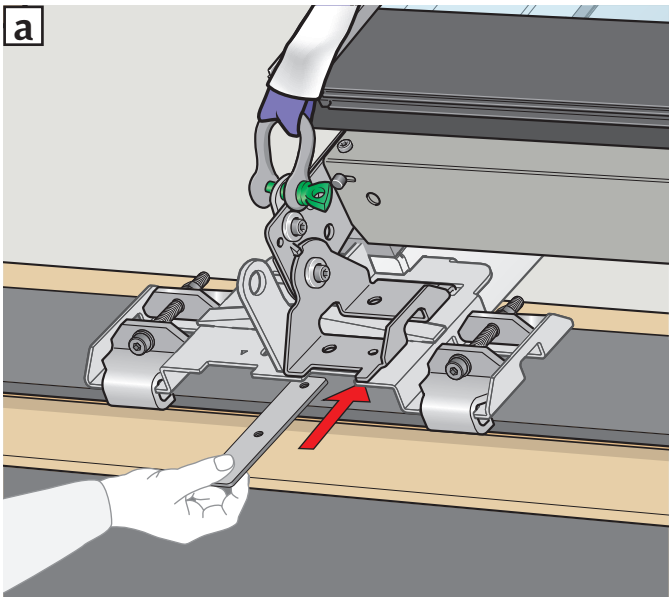
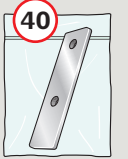

**i** → 4 5 6 7

19

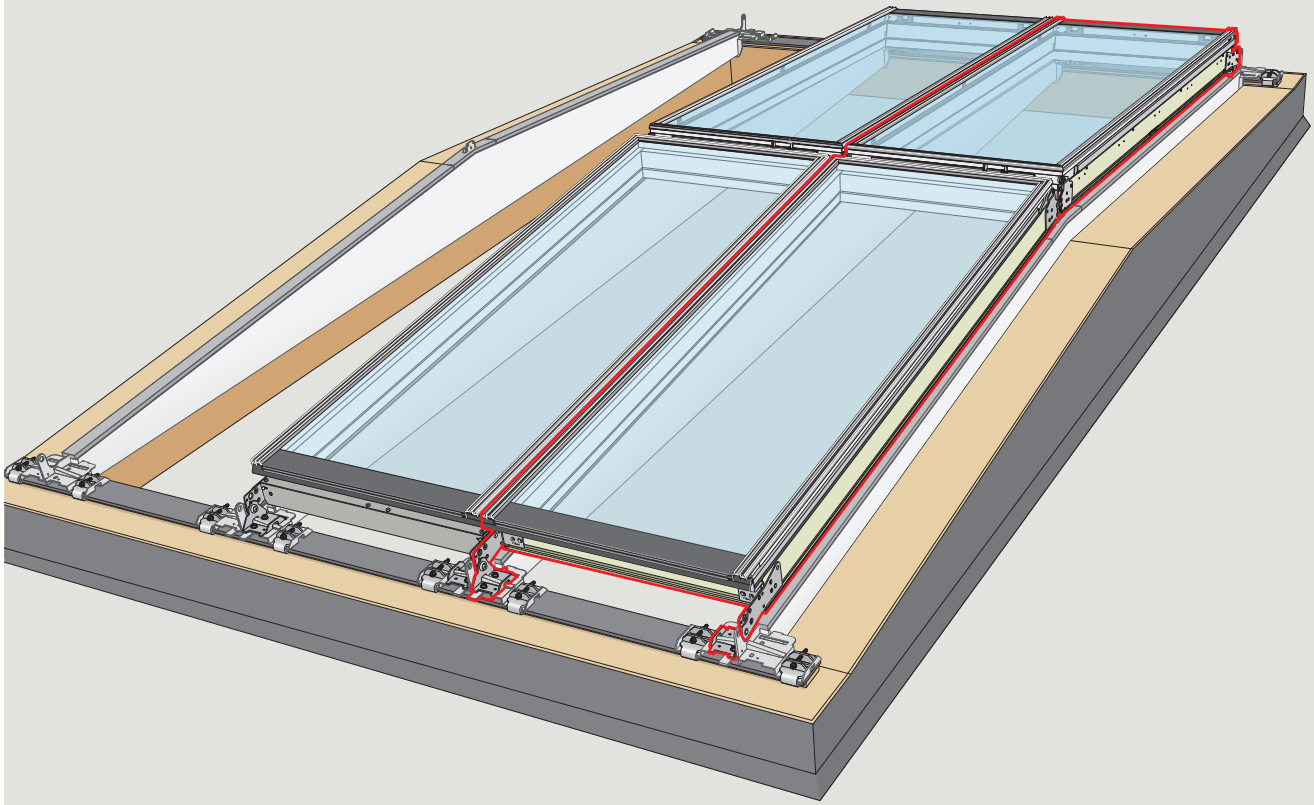

11

12

13

14

15

16

17

18

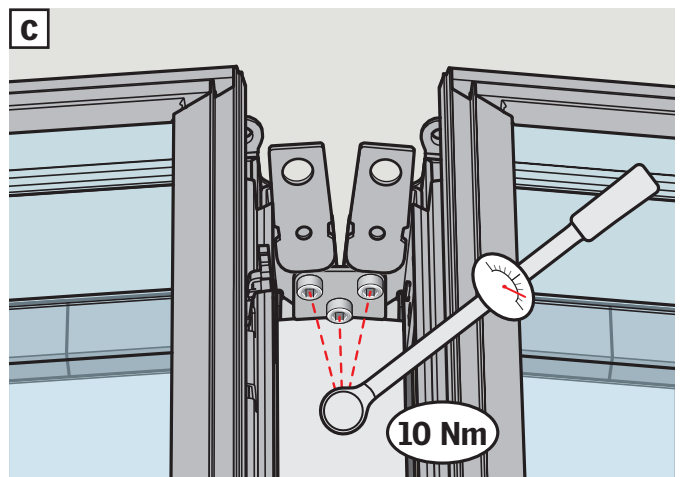
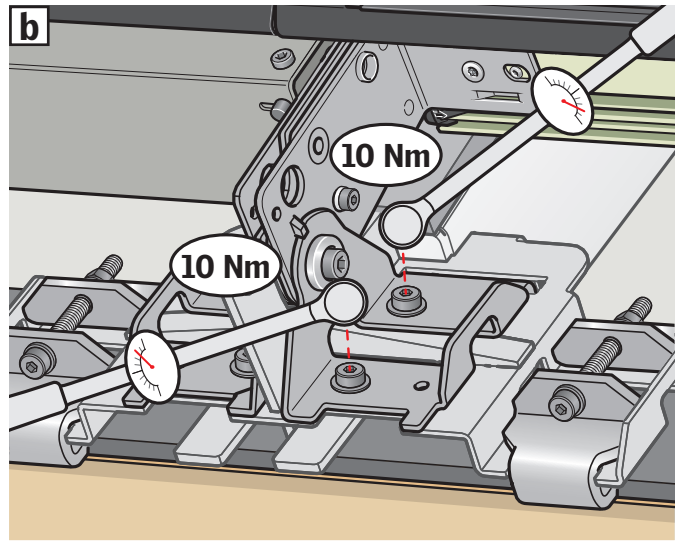
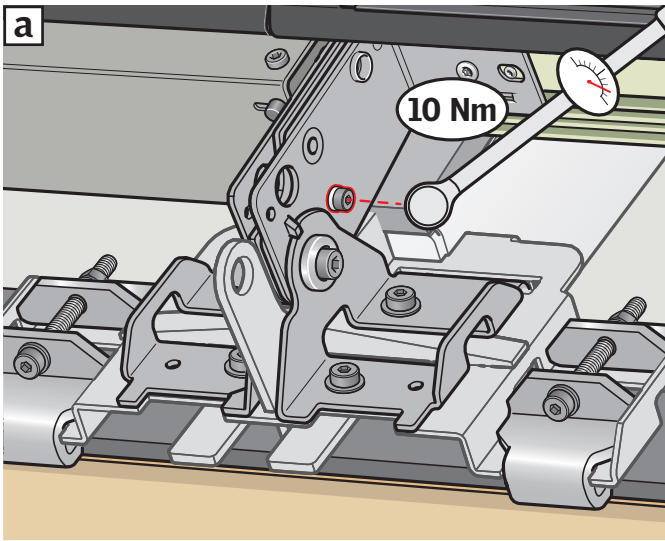
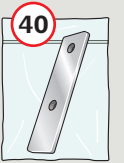
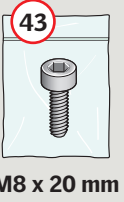
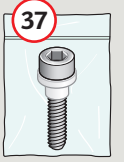
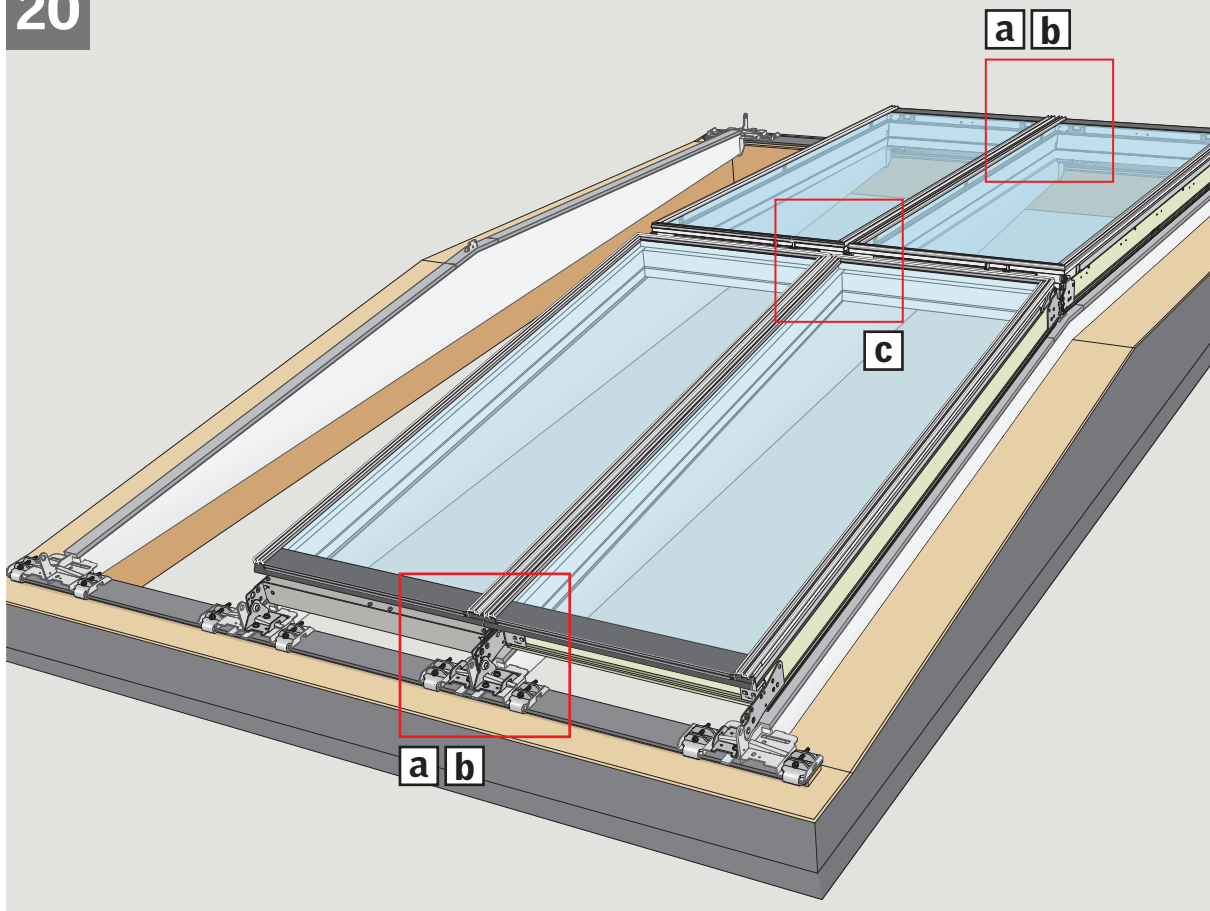

21

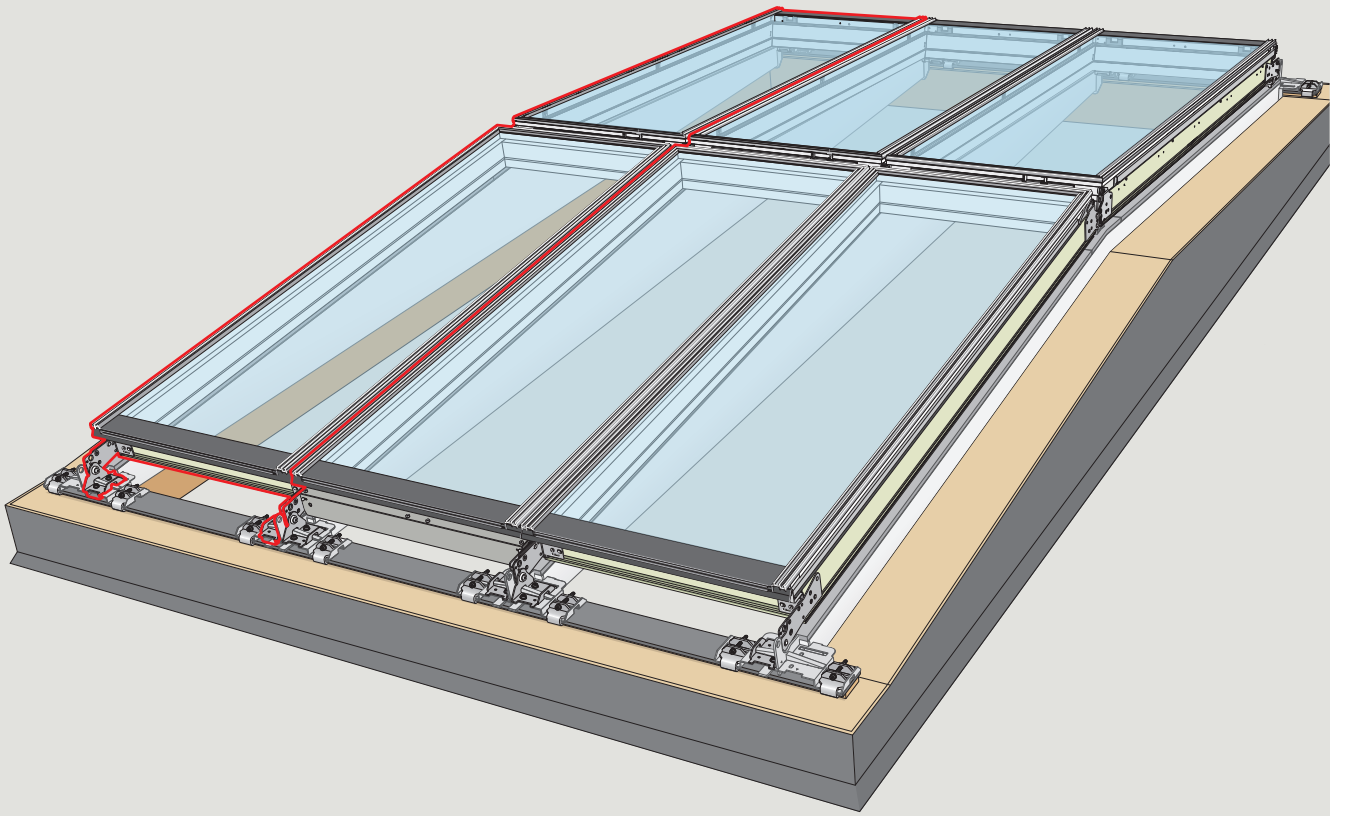

- 11
- 12
- 13
- 14
- 15
- 16
- 17
- 18
- 20



22

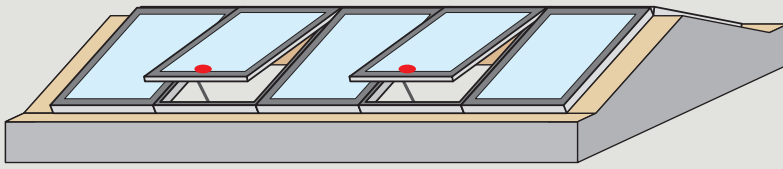

# KLC 400

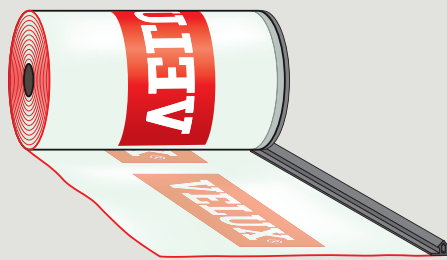
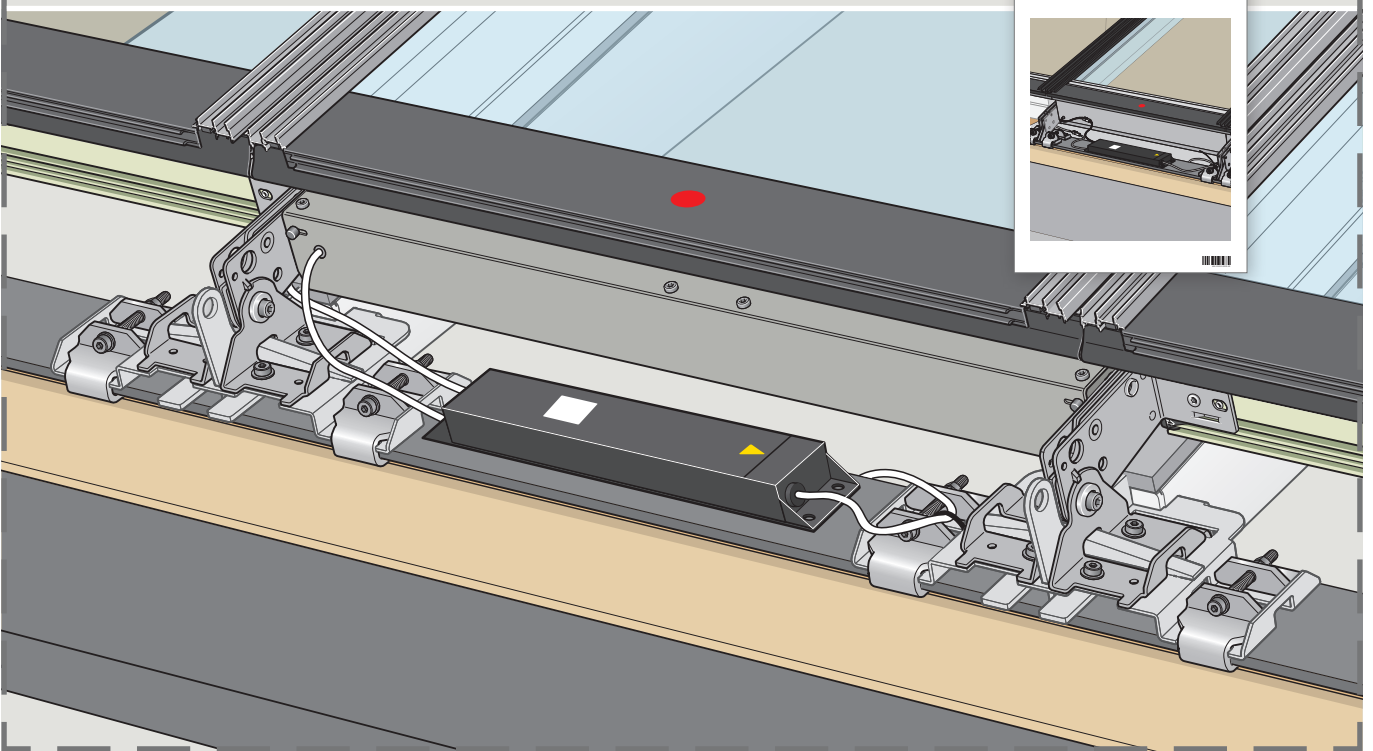
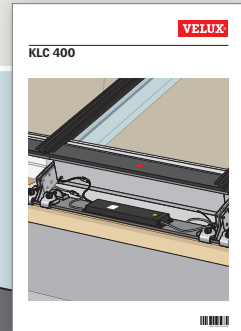

# BCX

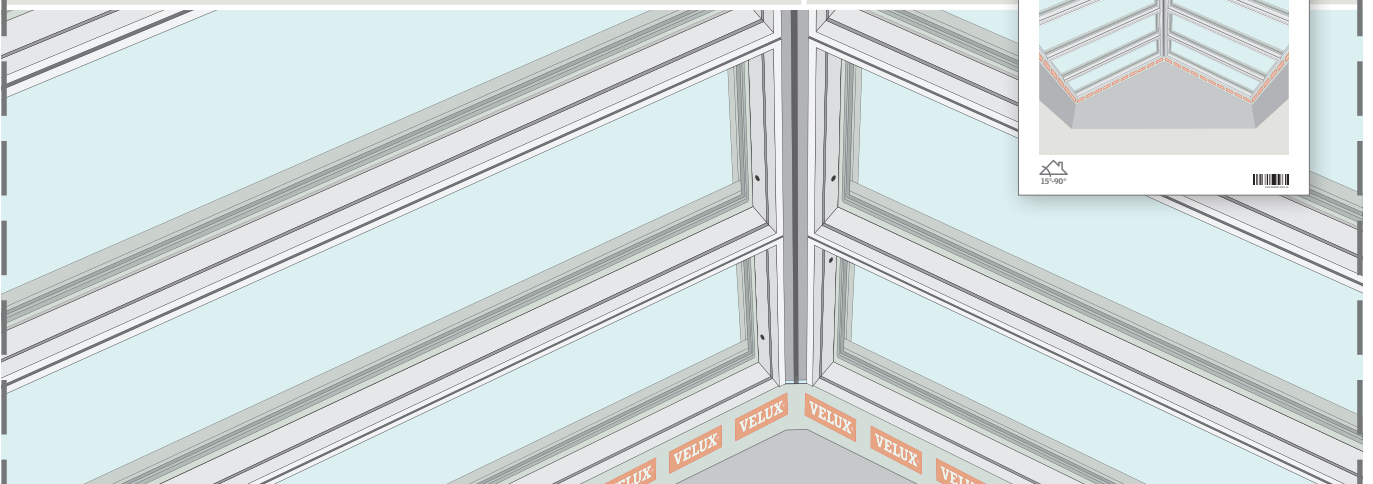
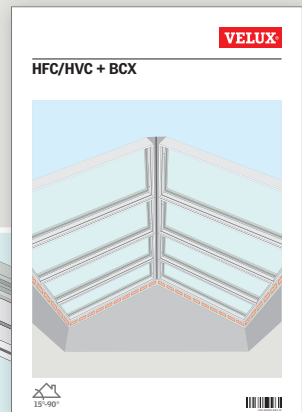

23

B2-R<sub>5°</sub>



5,5 x 27 mm

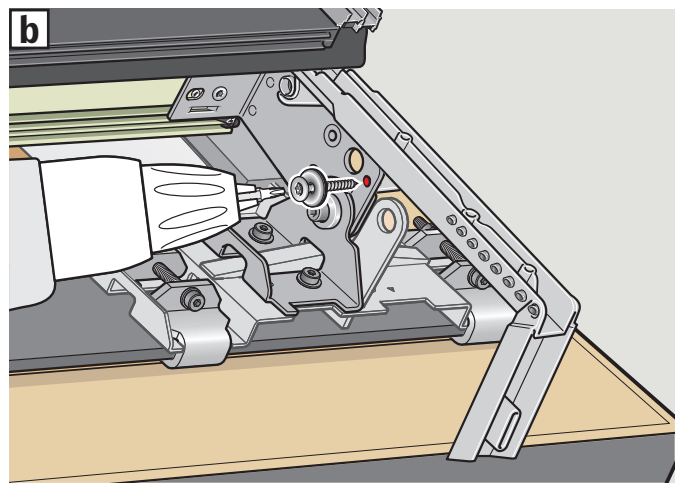
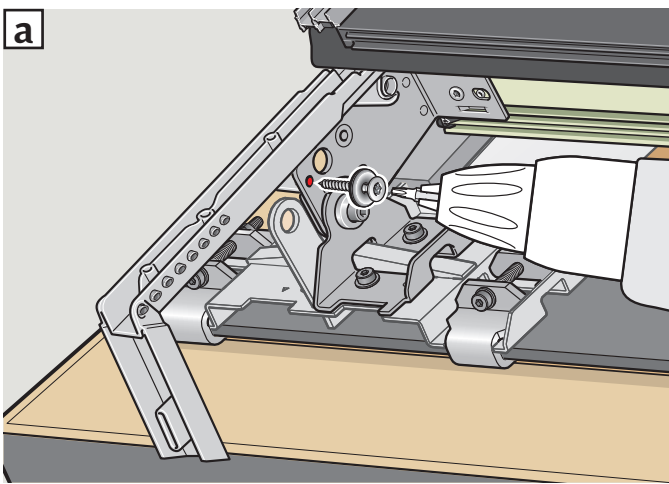
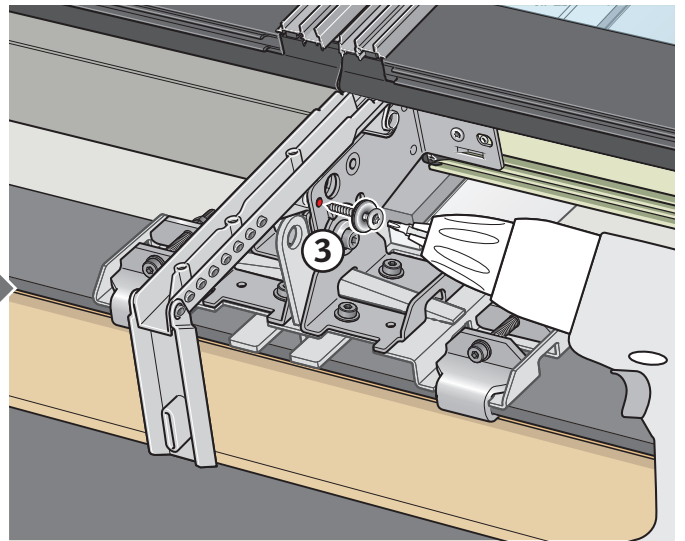
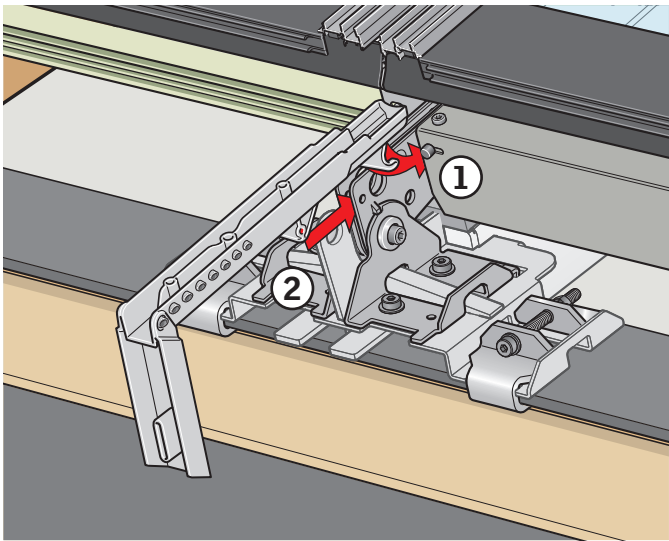
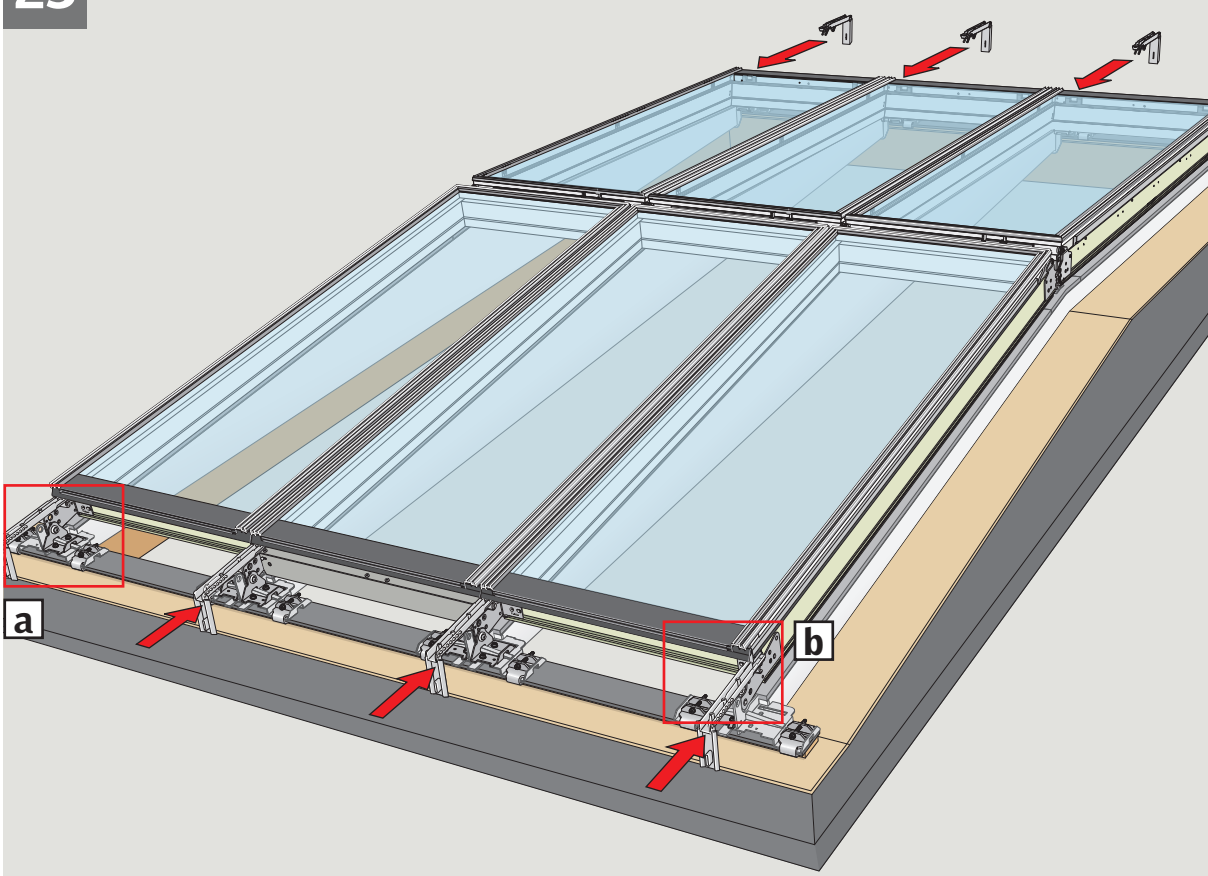
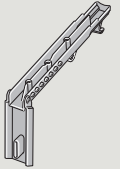

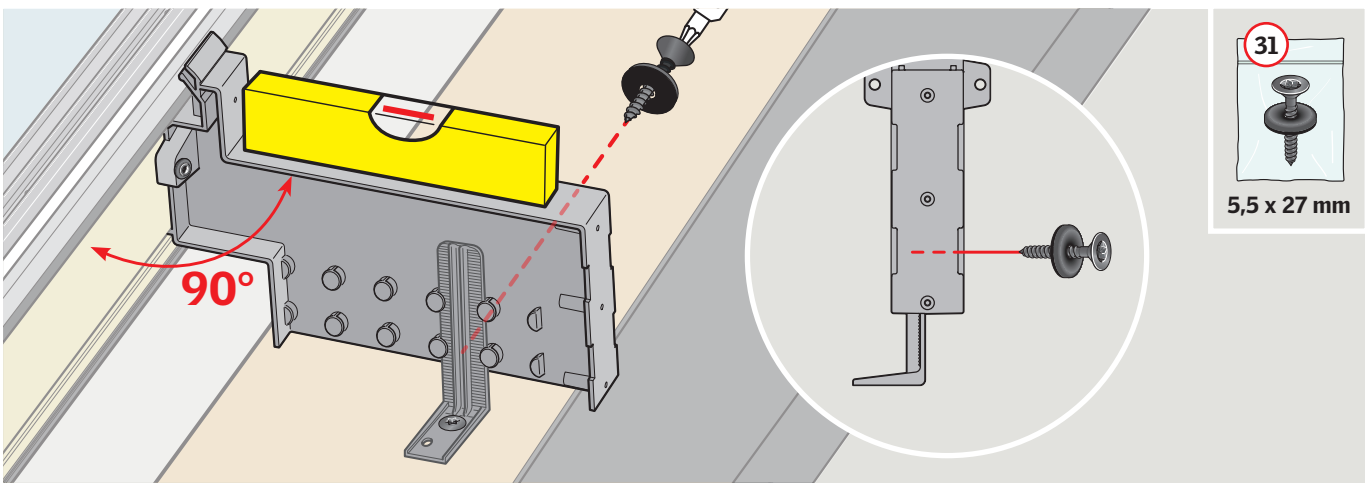
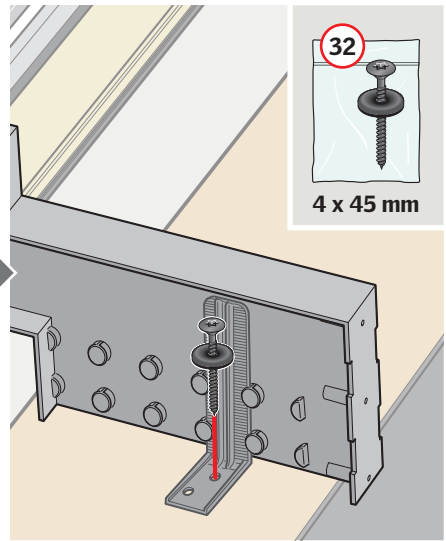
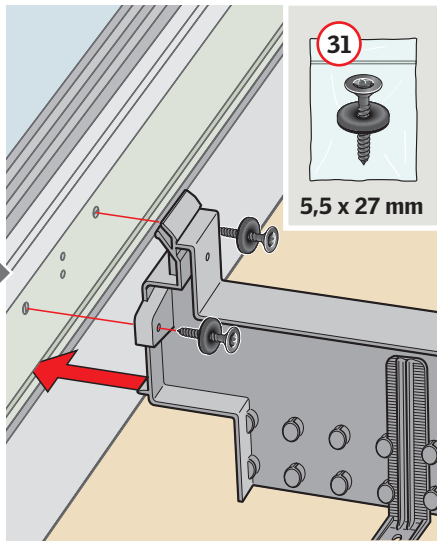
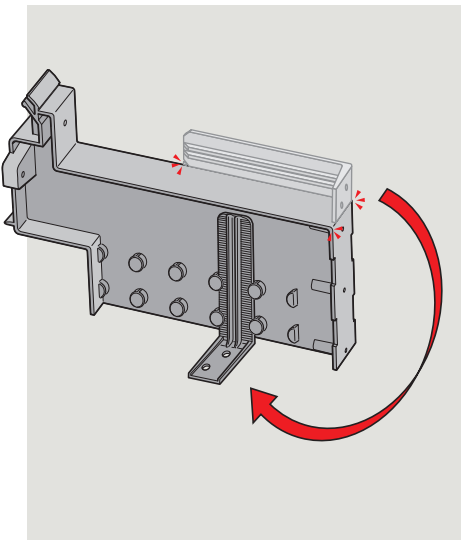
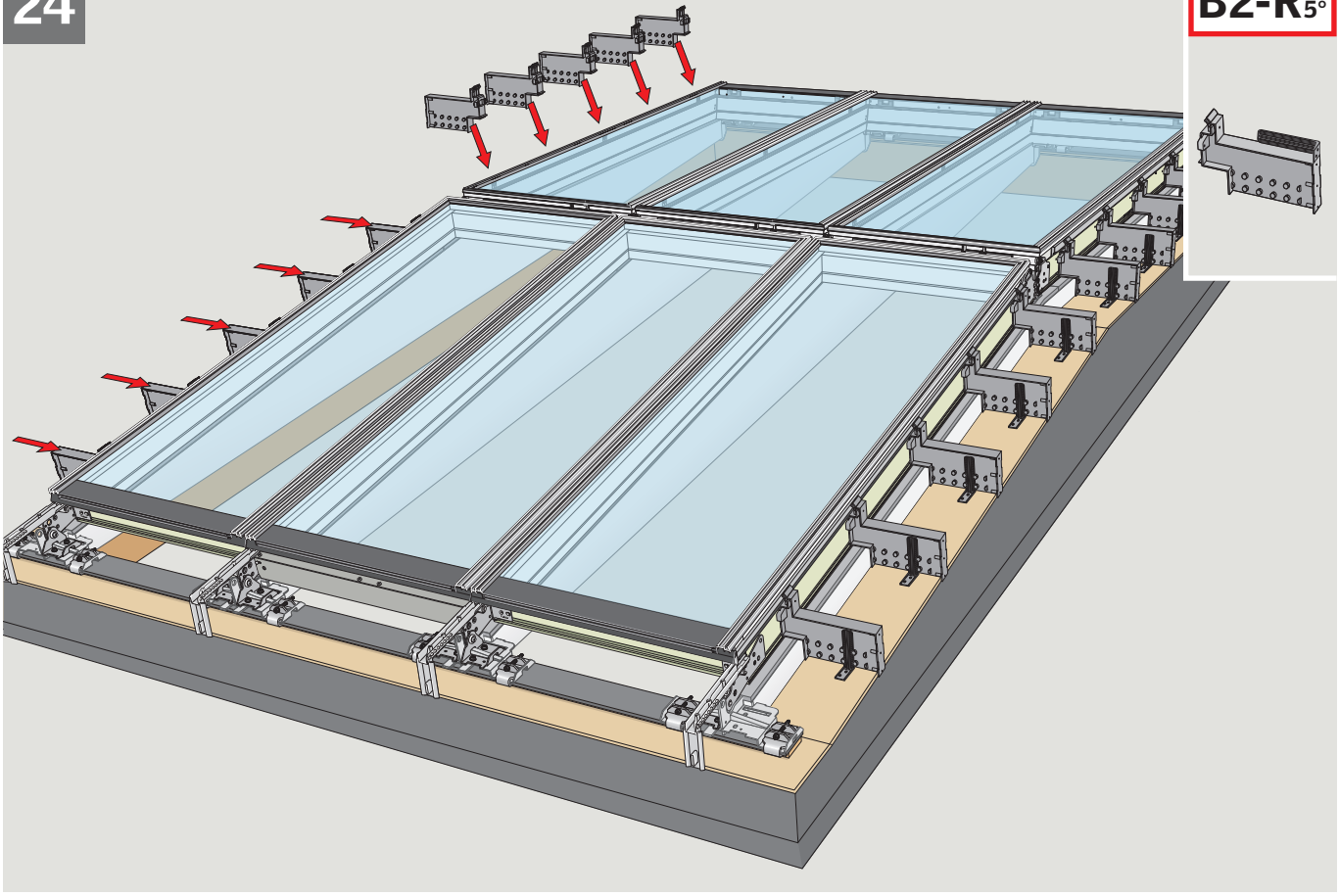

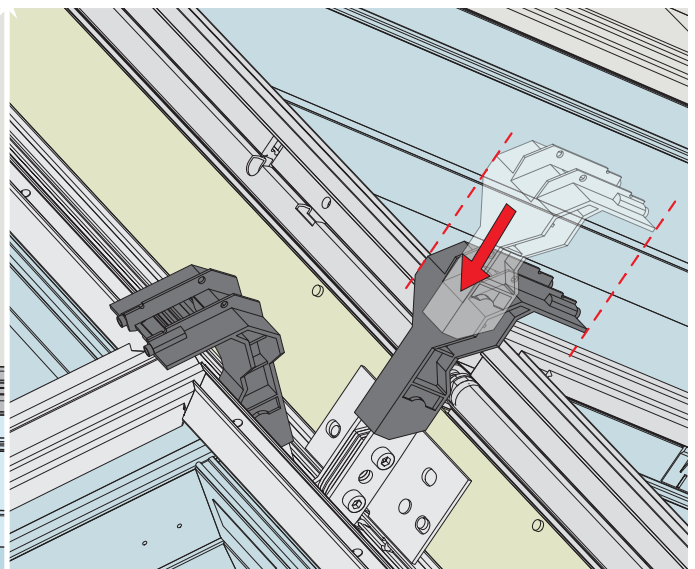
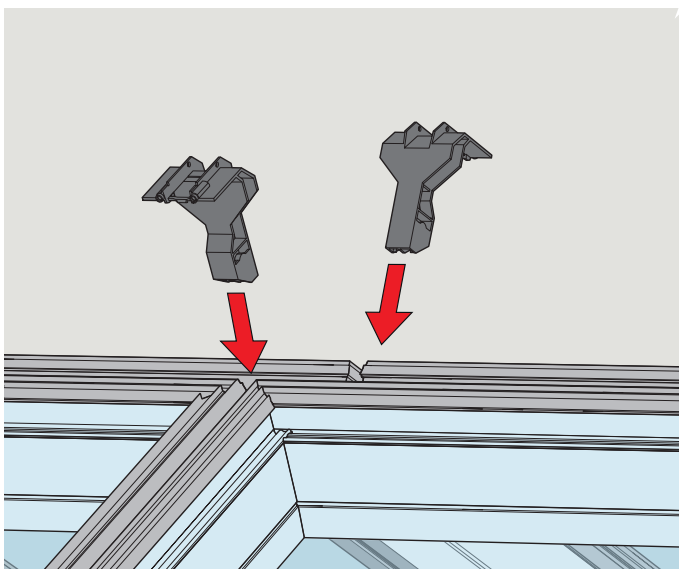
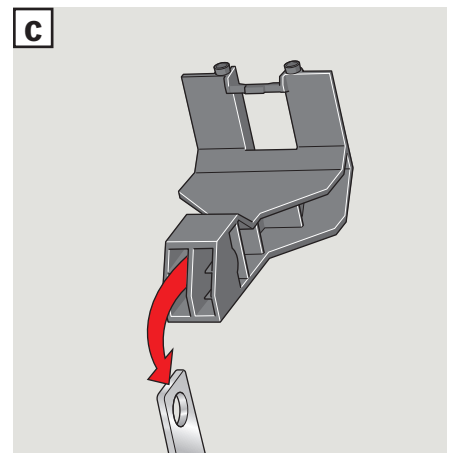
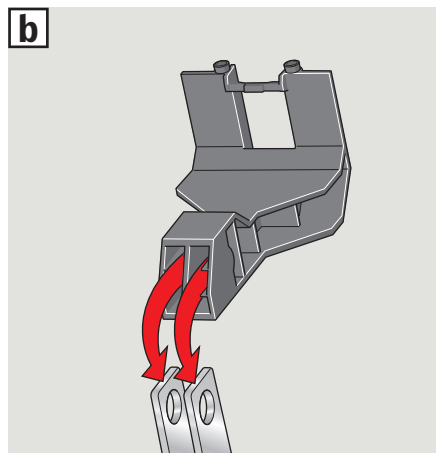
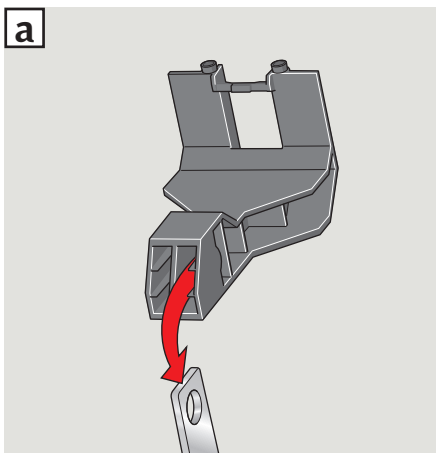
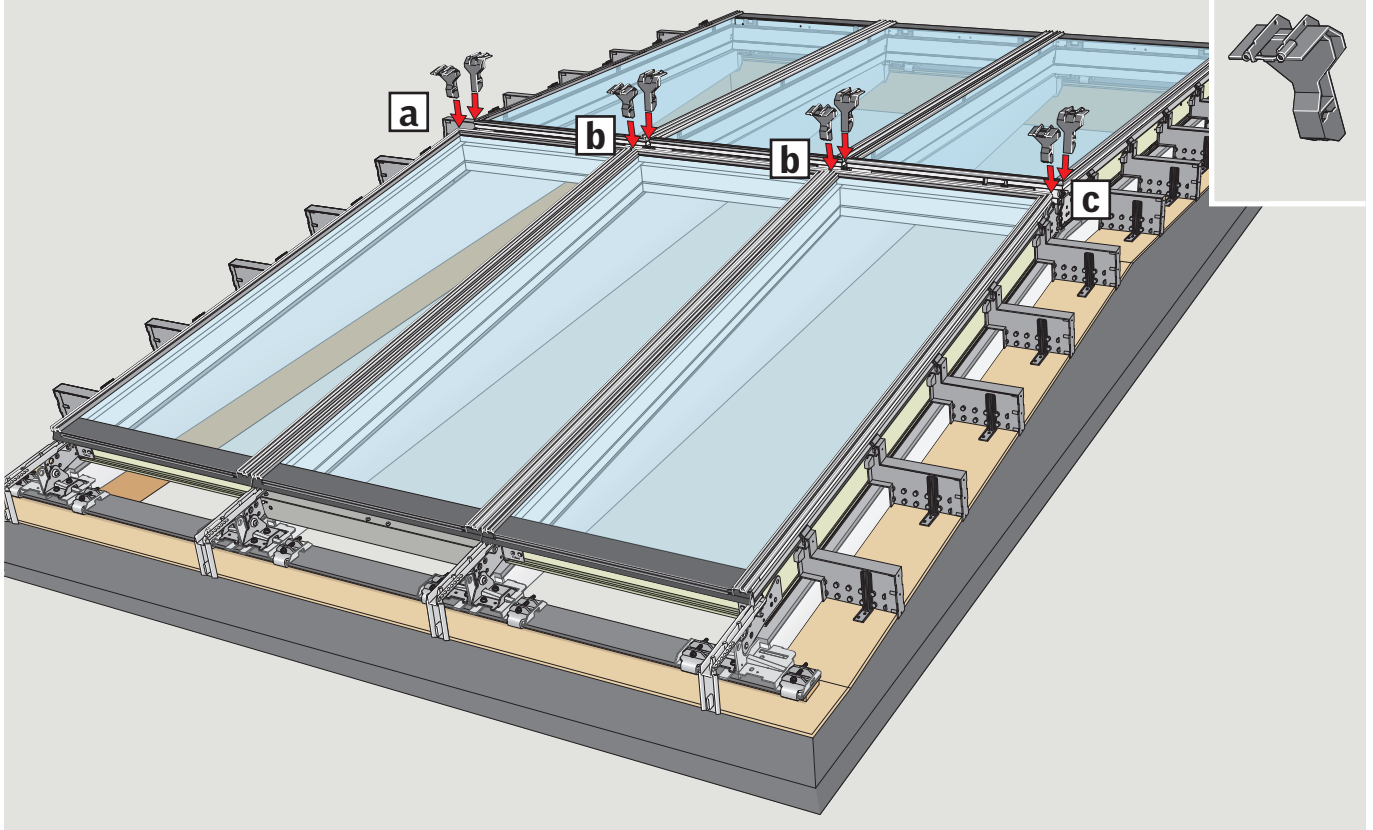

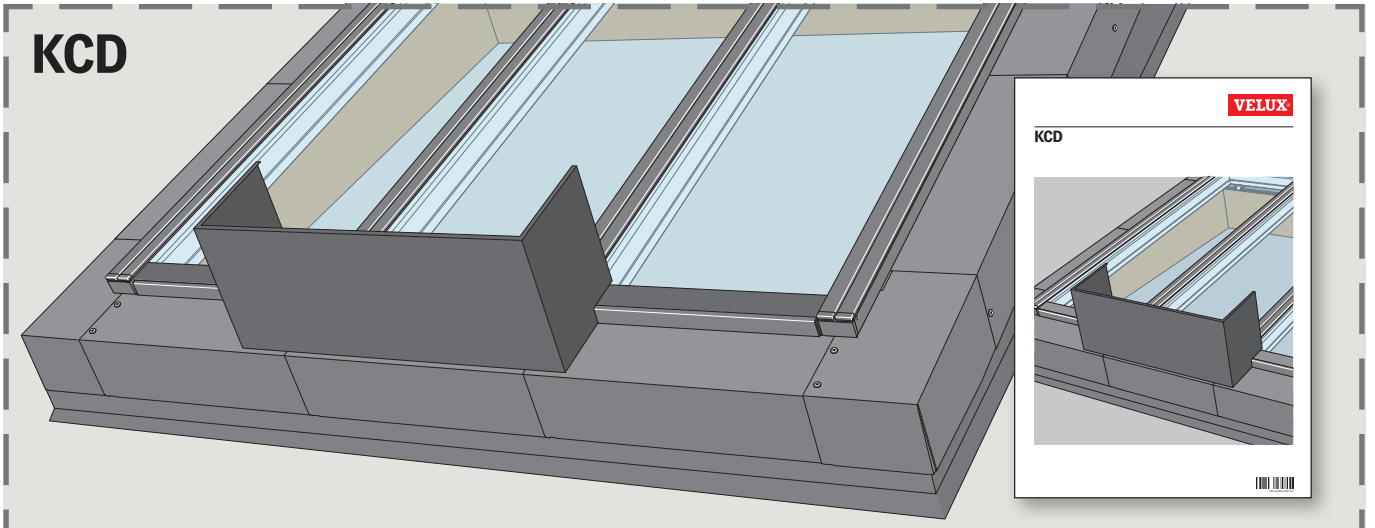
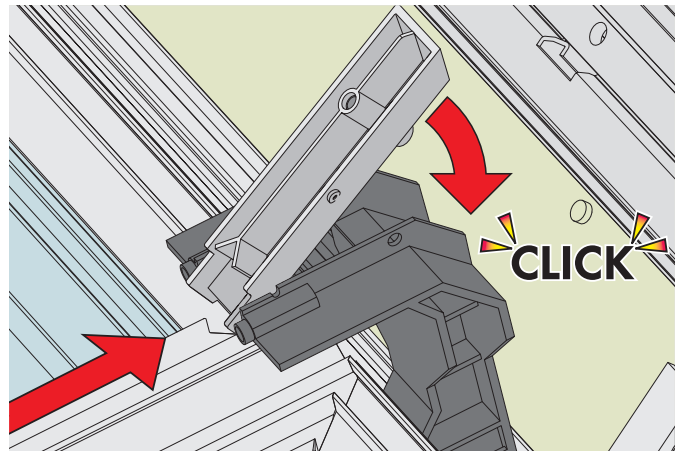
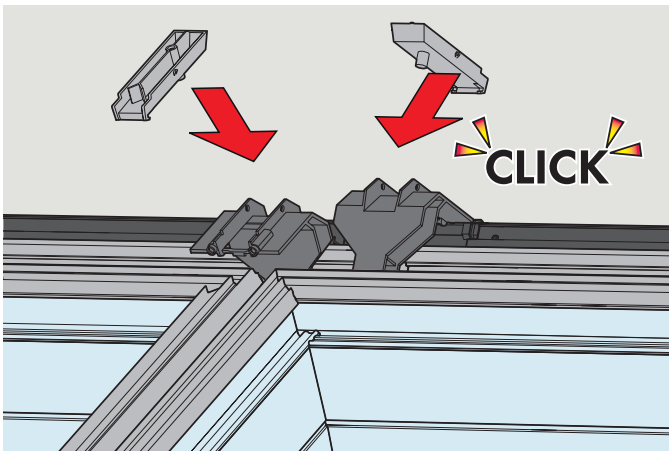
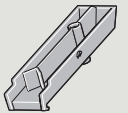
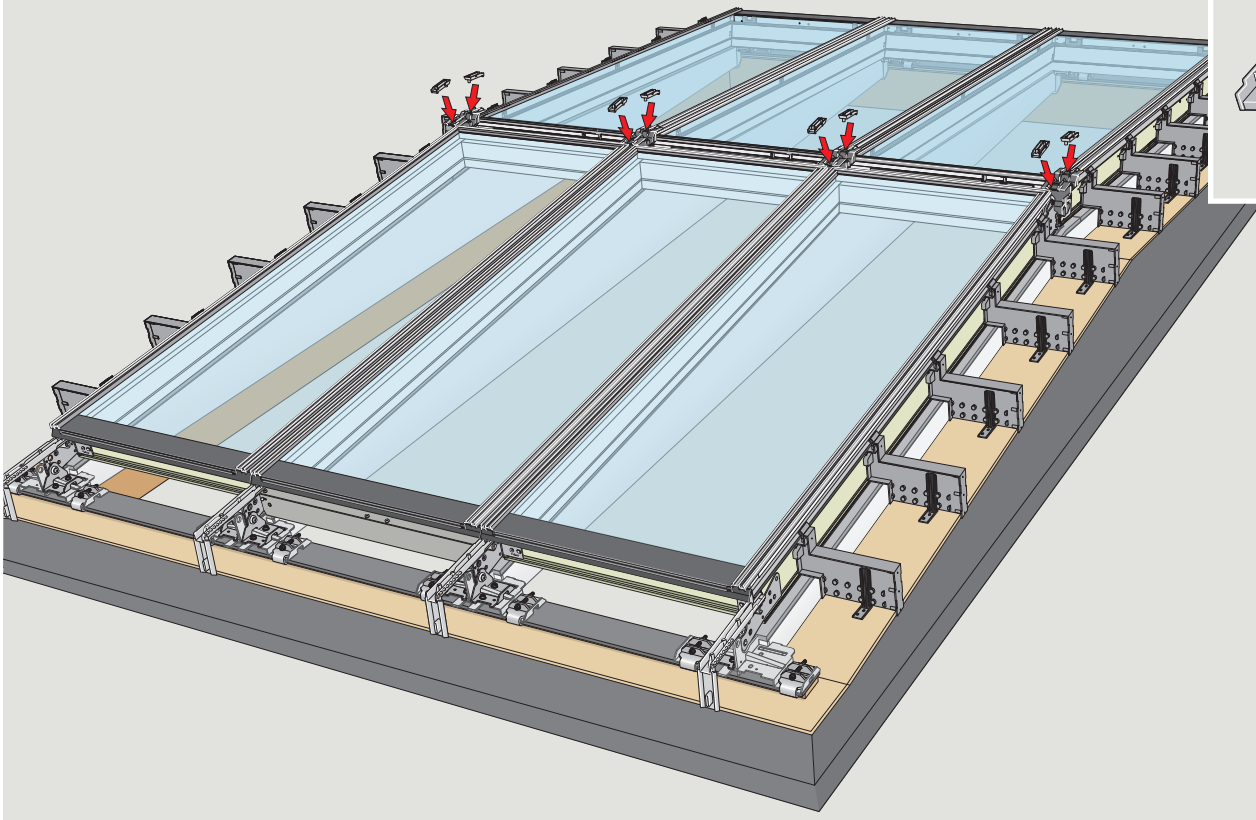

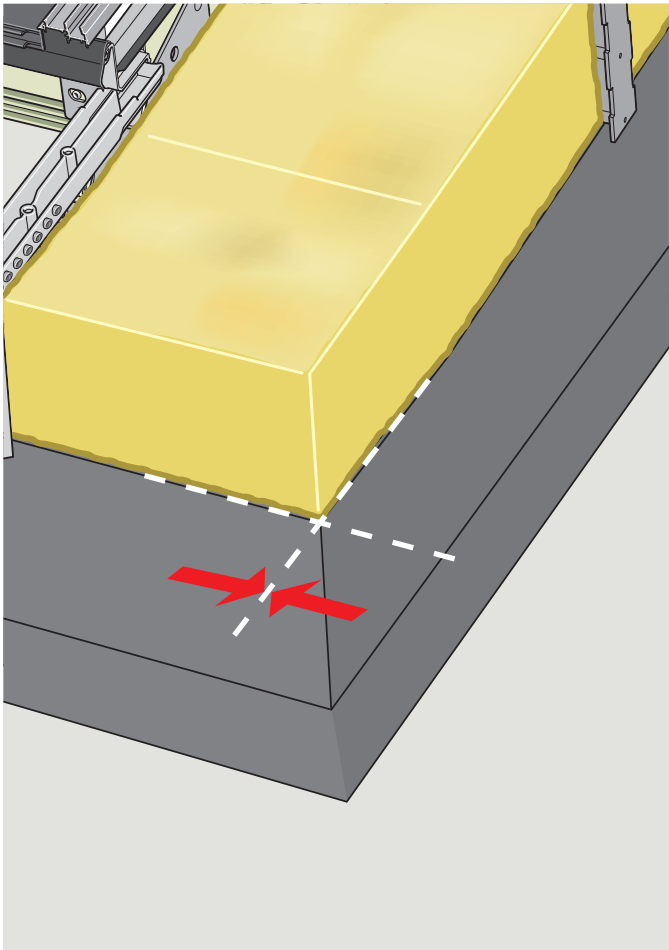
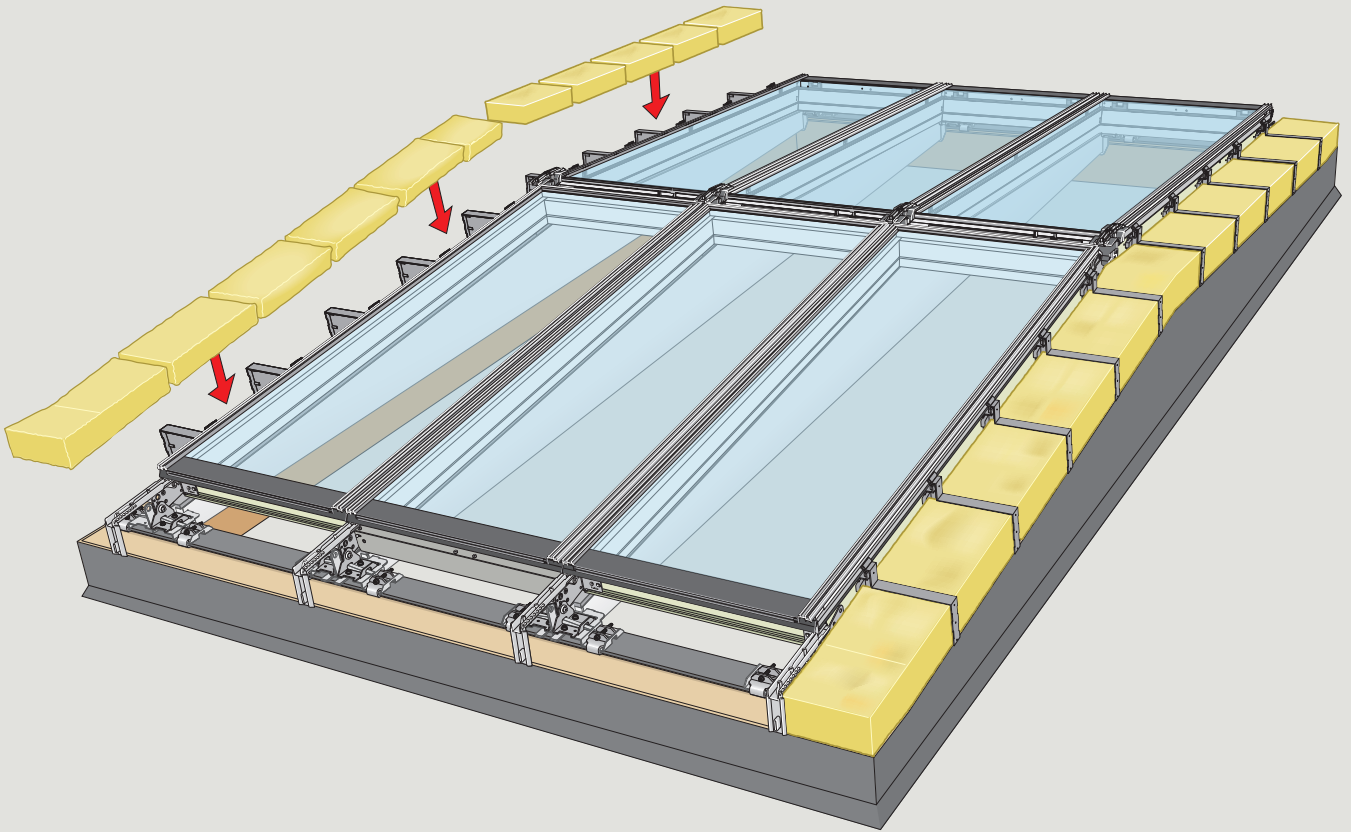

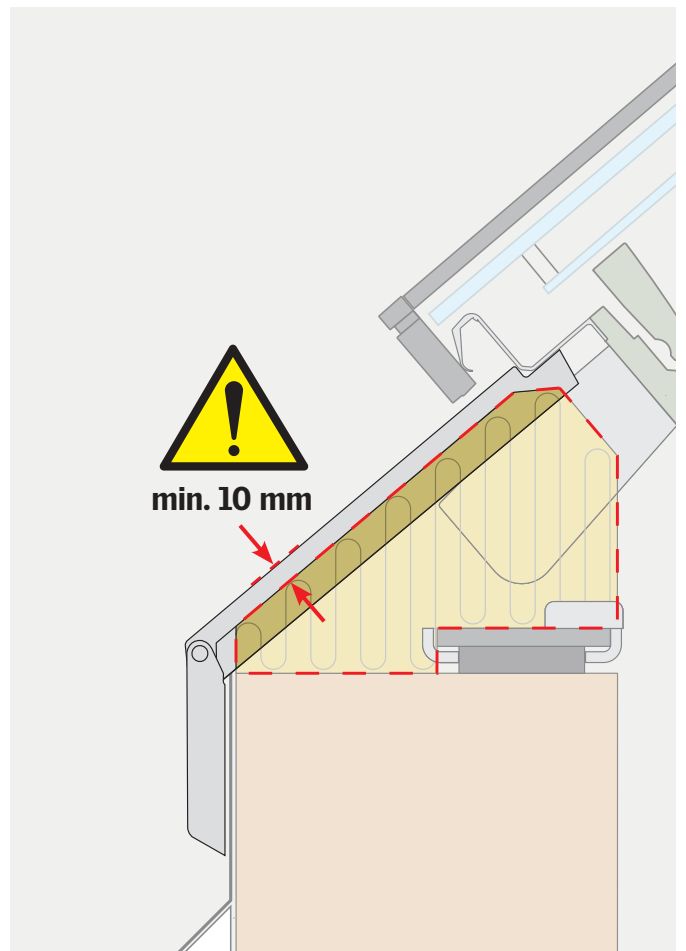
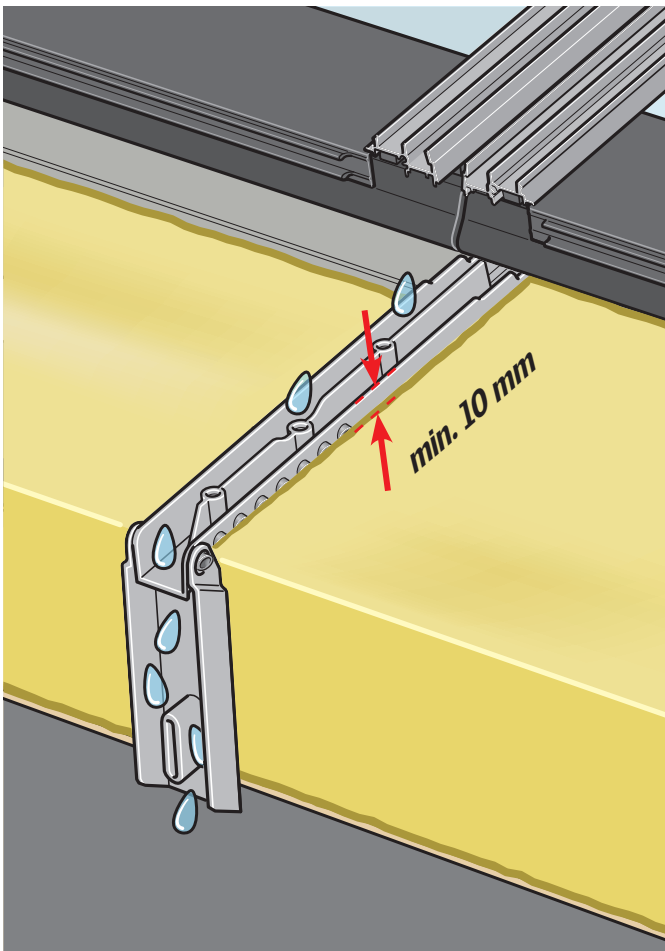
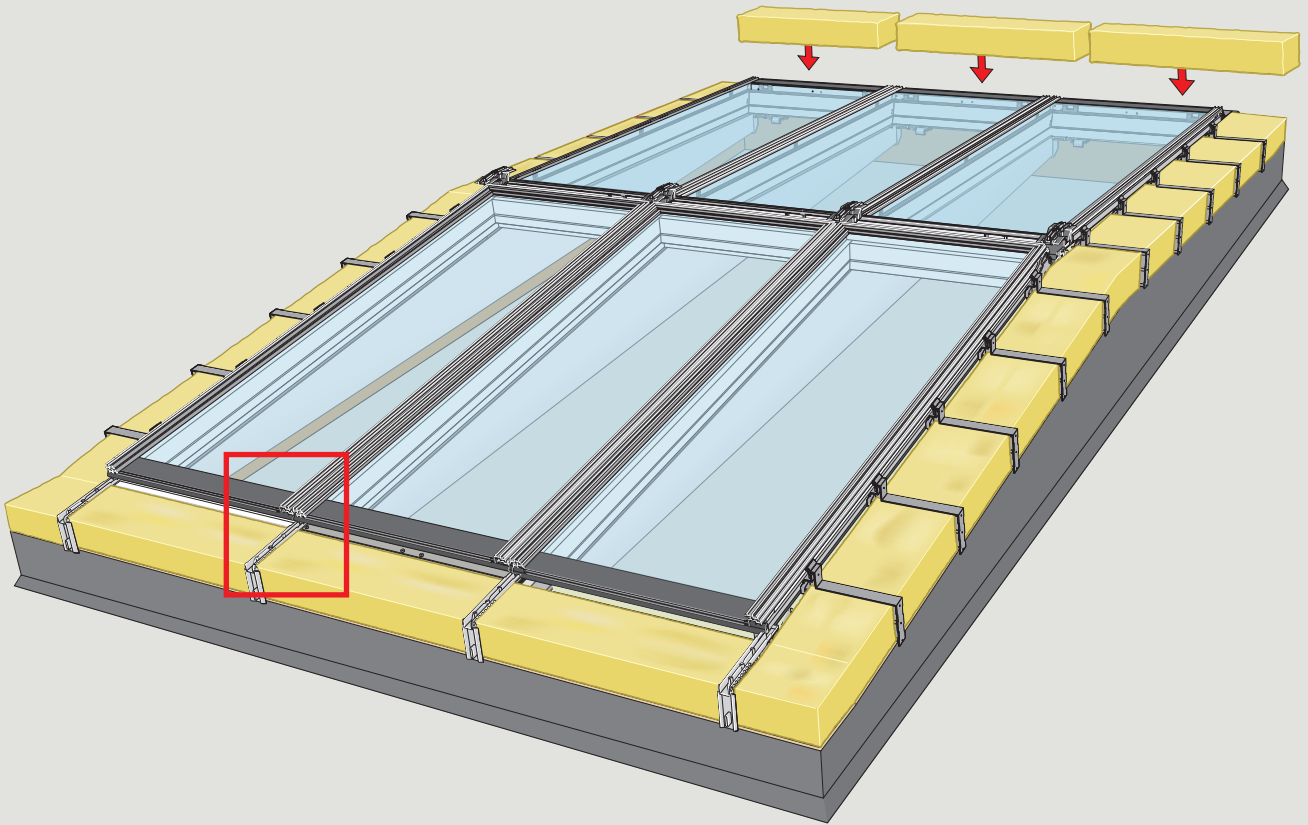

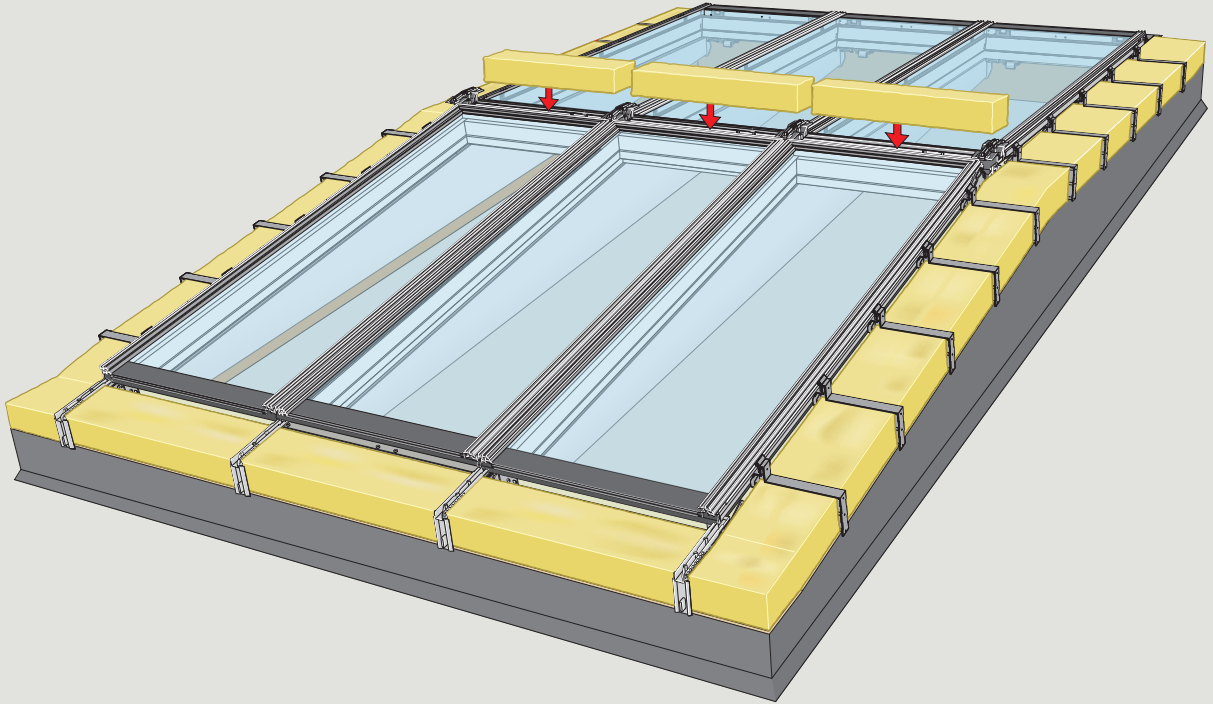



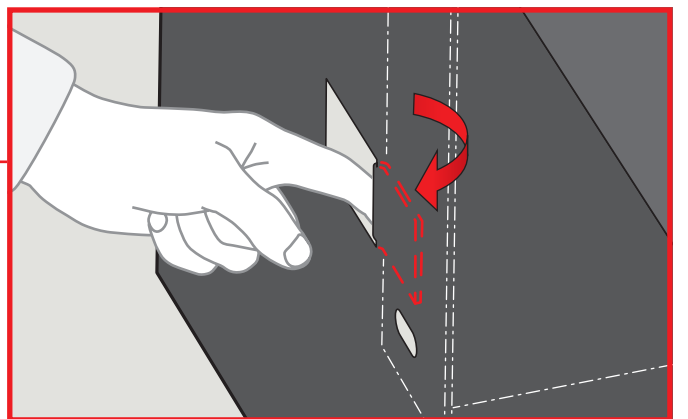
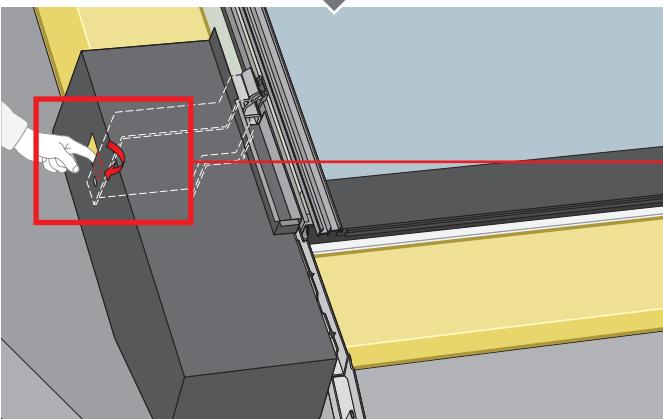
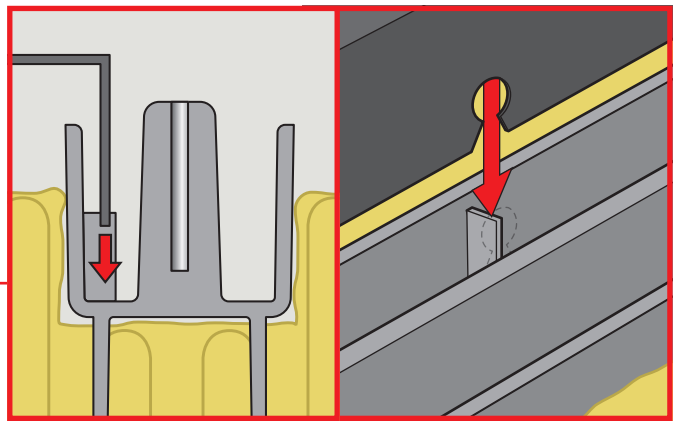
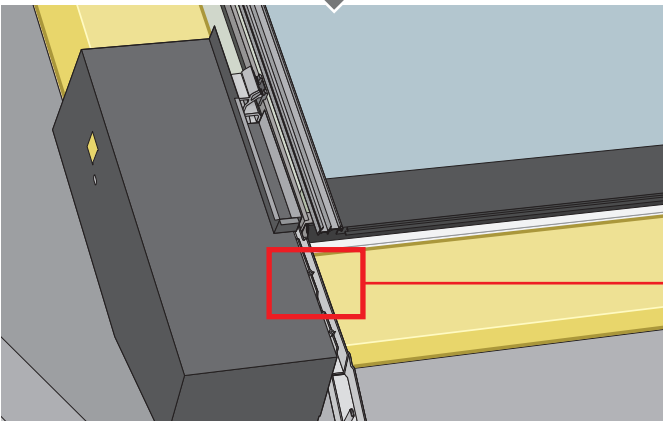
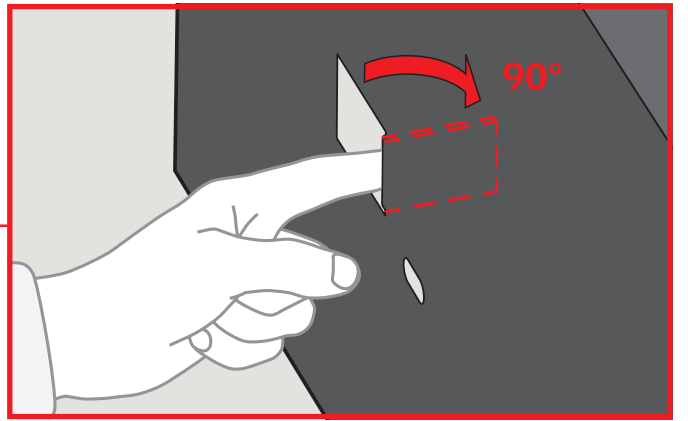
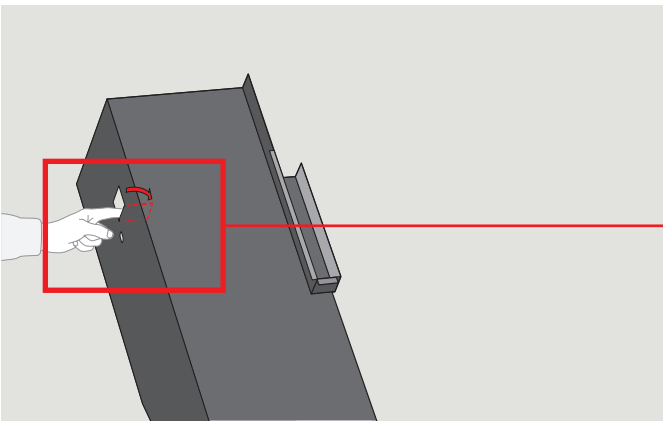
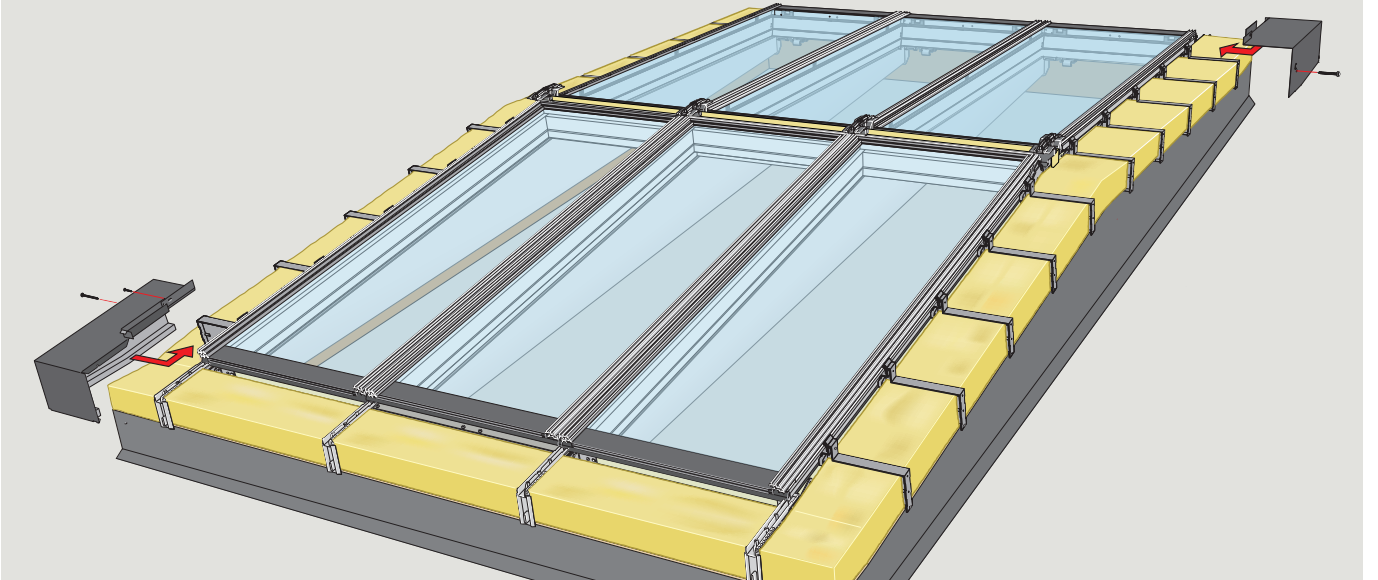

31

C1-R<sub>5°</sub>

B2-R<sub>5°</sub>



5,5 x 27 mm

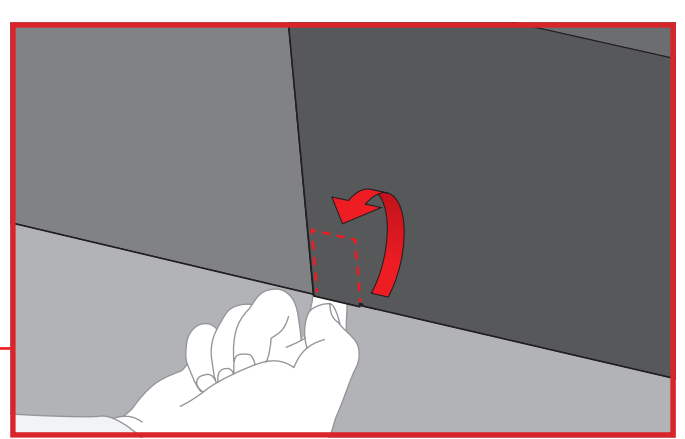
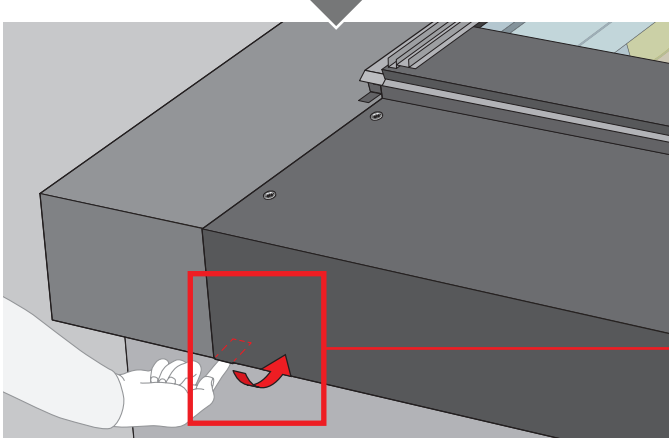
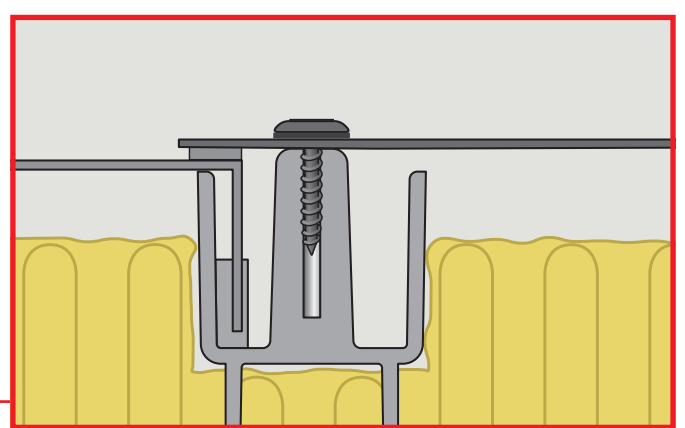
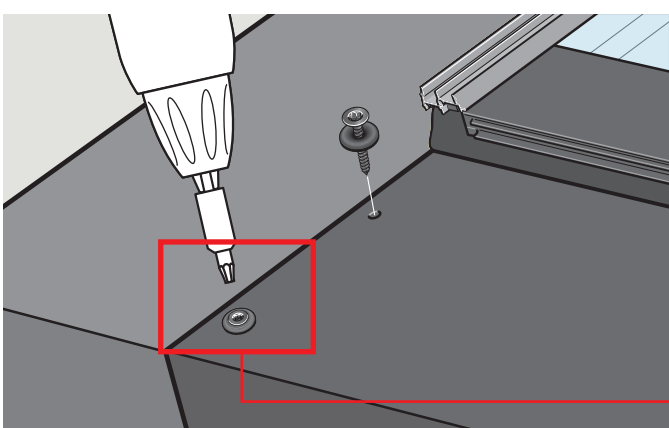
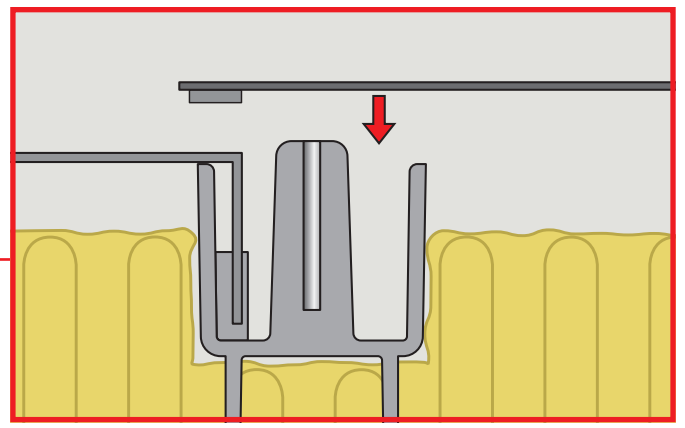
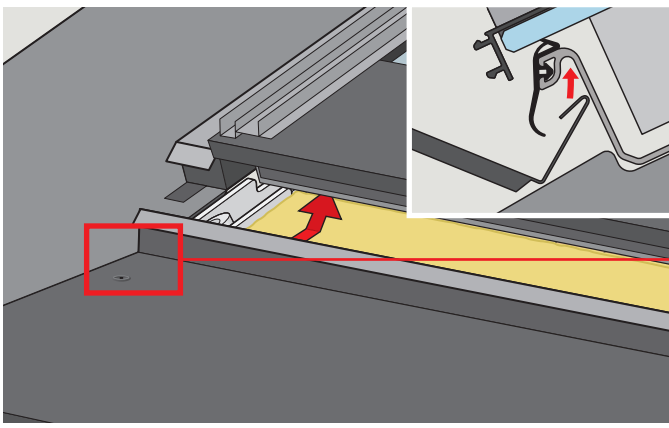
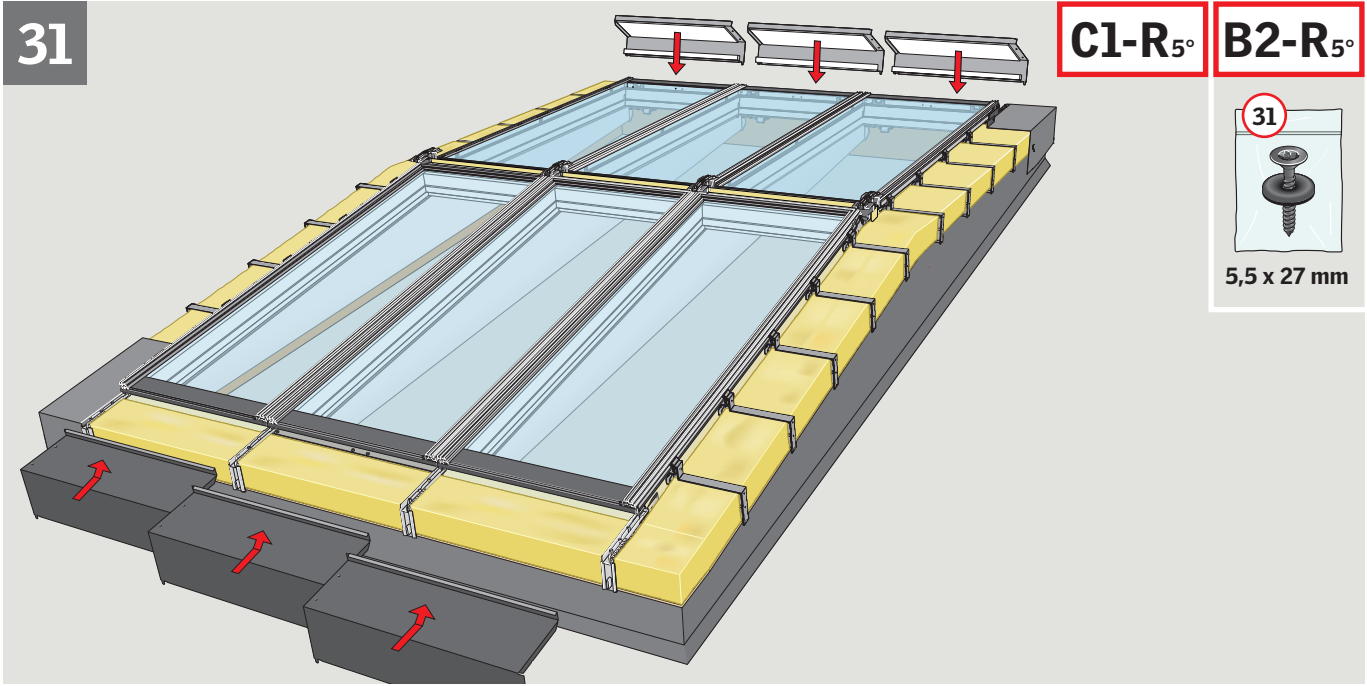

32

C3-R<sub>5°</sub> B2-R<sub>5°</sub>

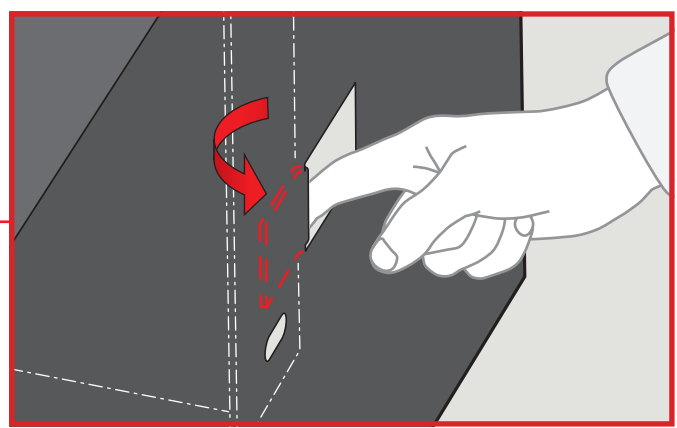
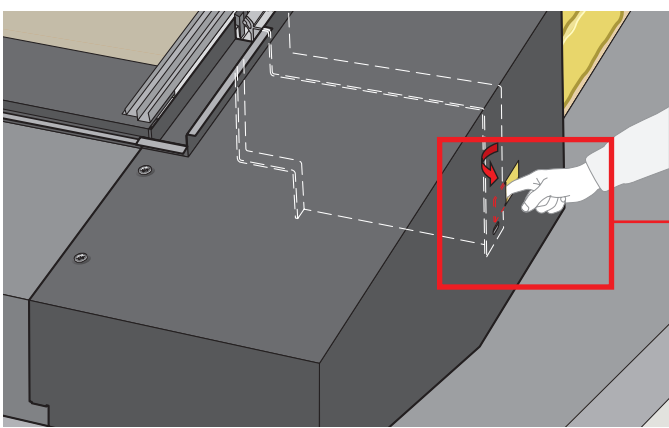
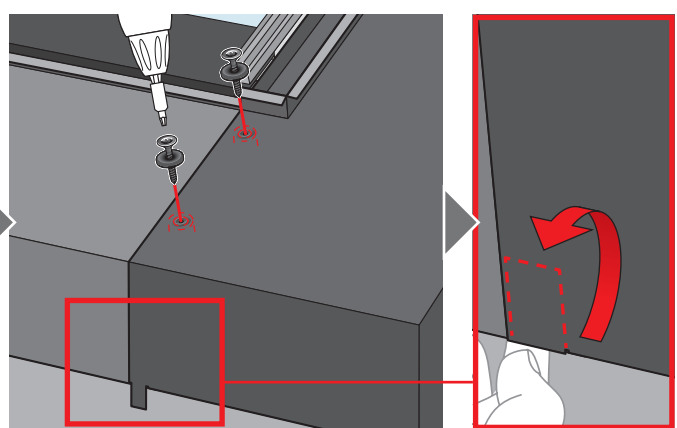
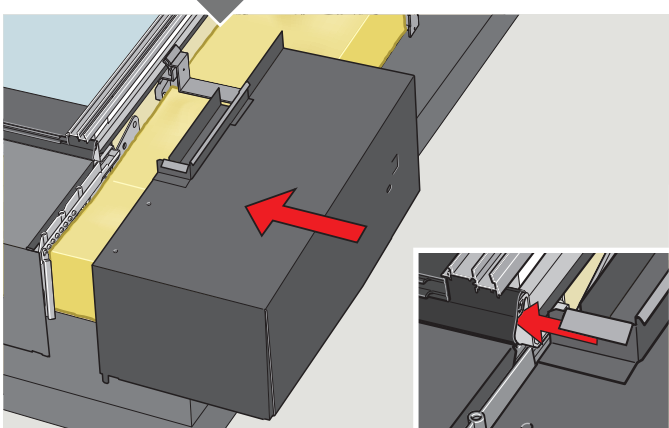
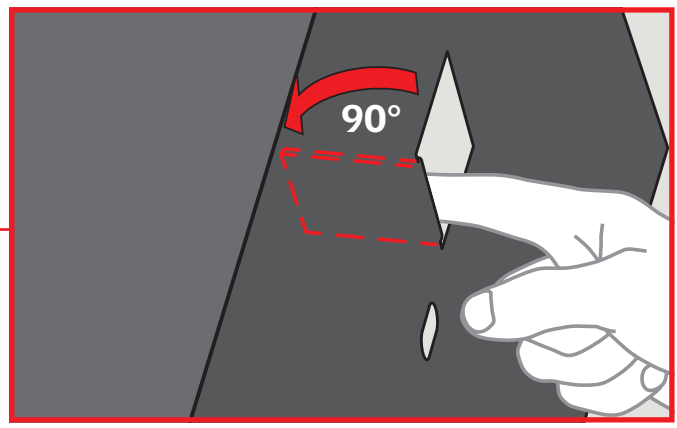
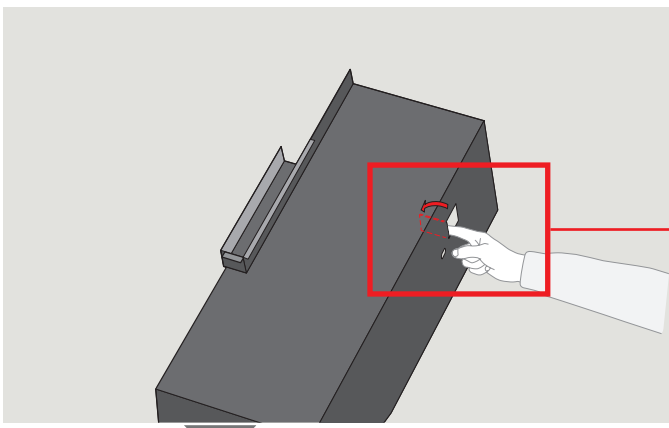
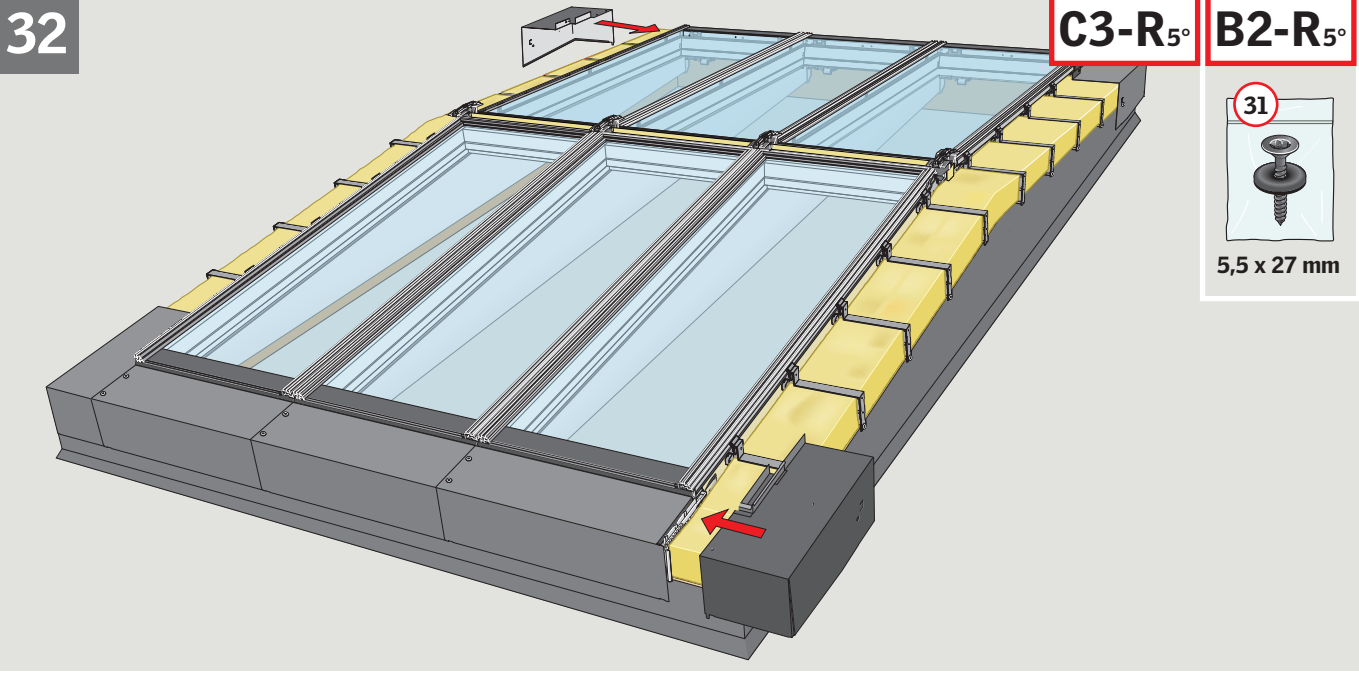

< 2 m =

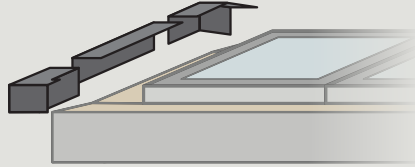
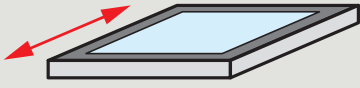

> 2 m =

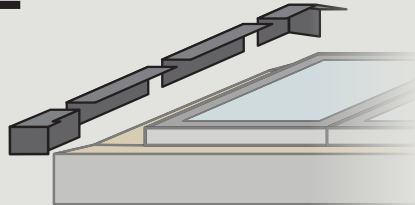
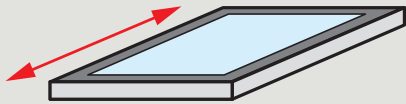

34

C3-R<sub>5°</sub> B2-R<sub>5°</sub>

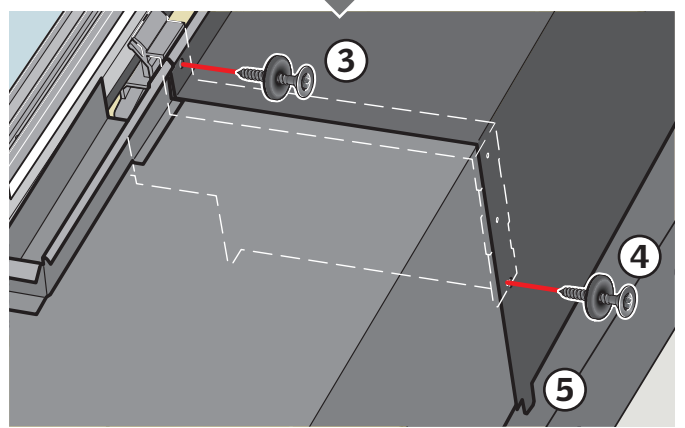
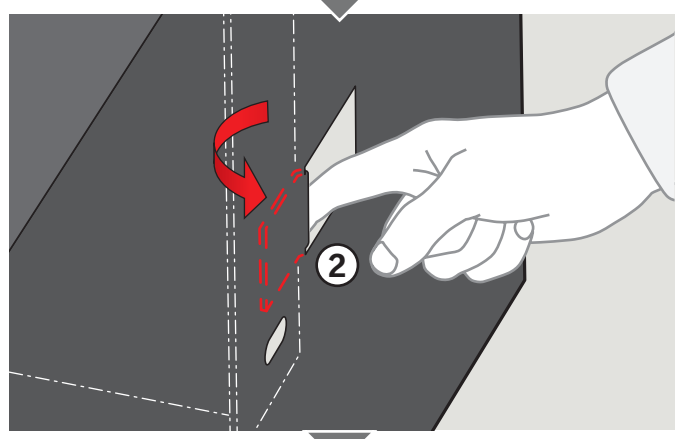
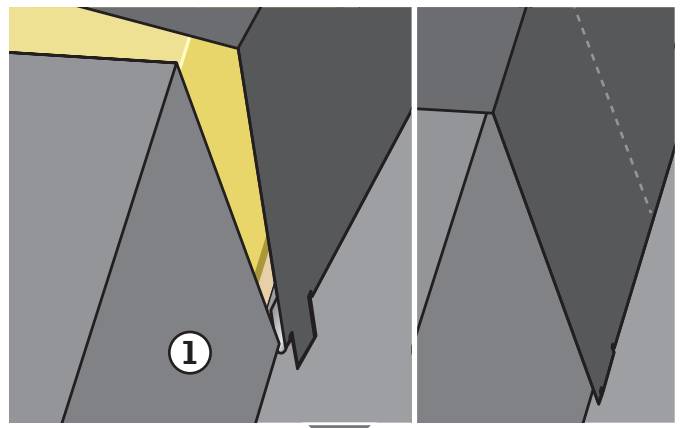
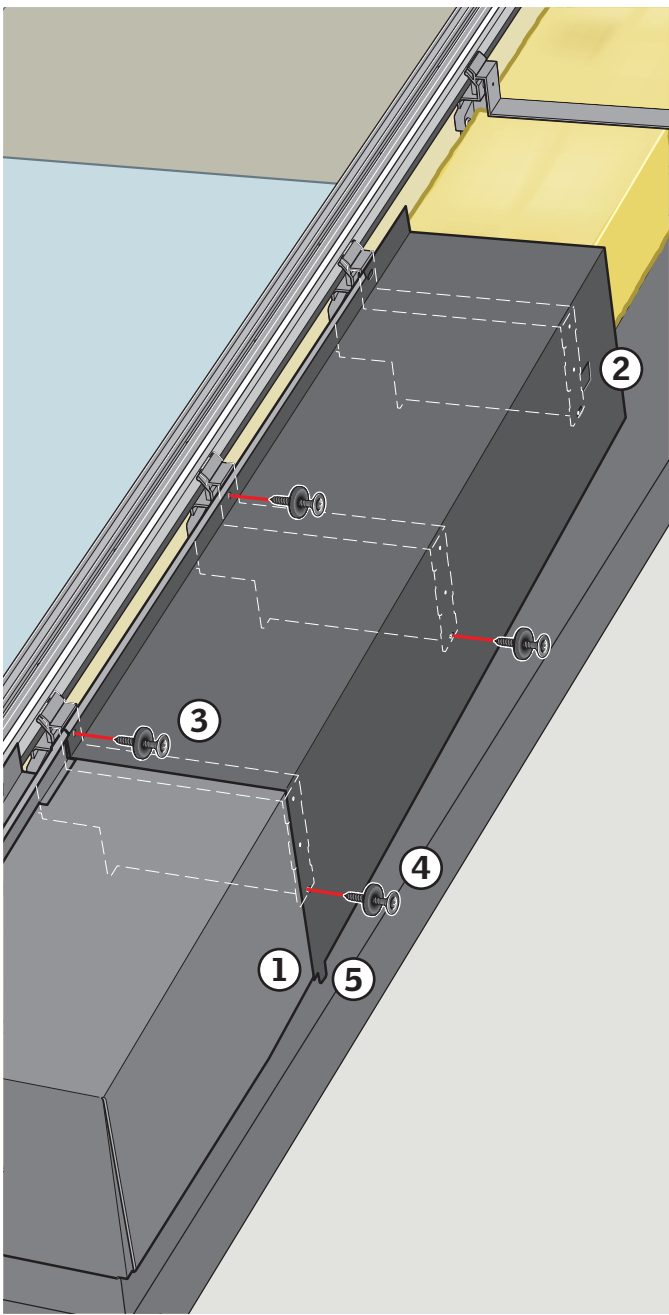
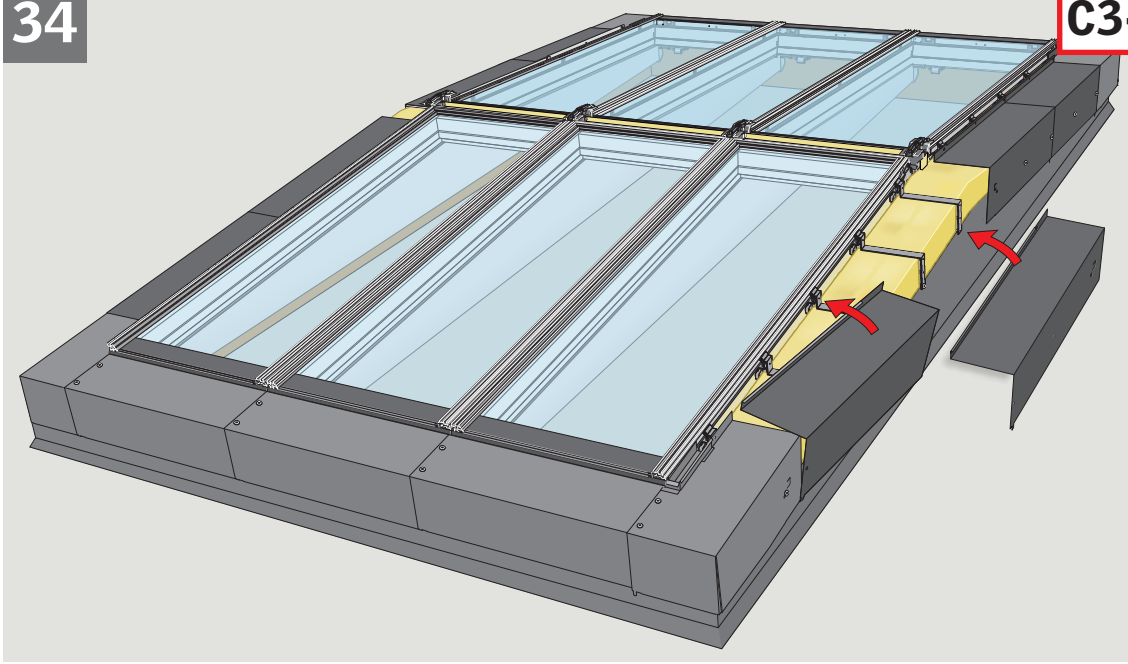
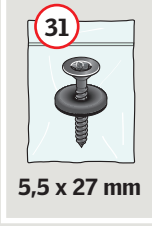



5,5 x 27 mm

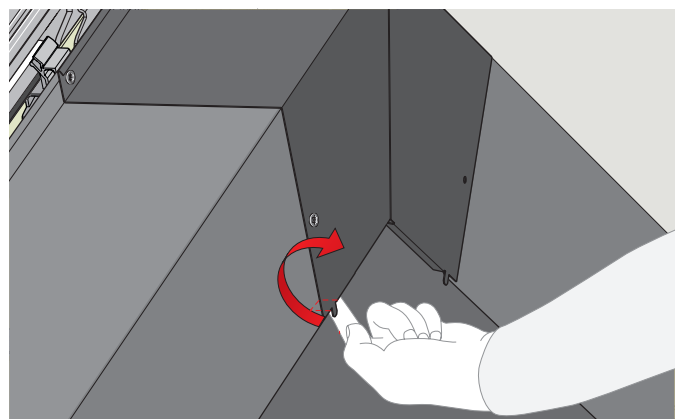
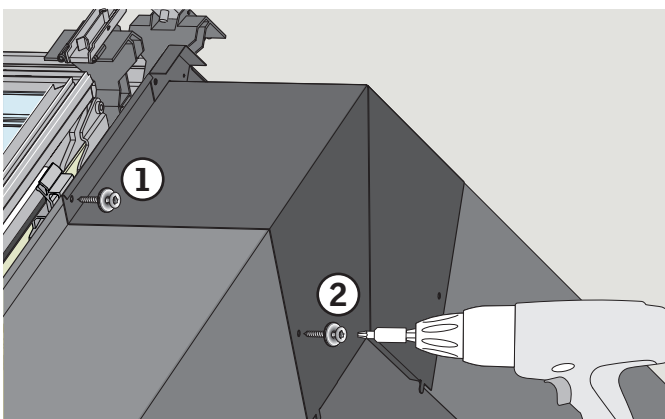
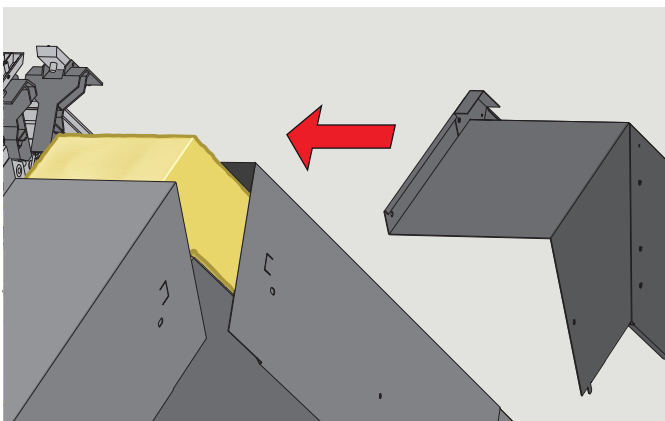
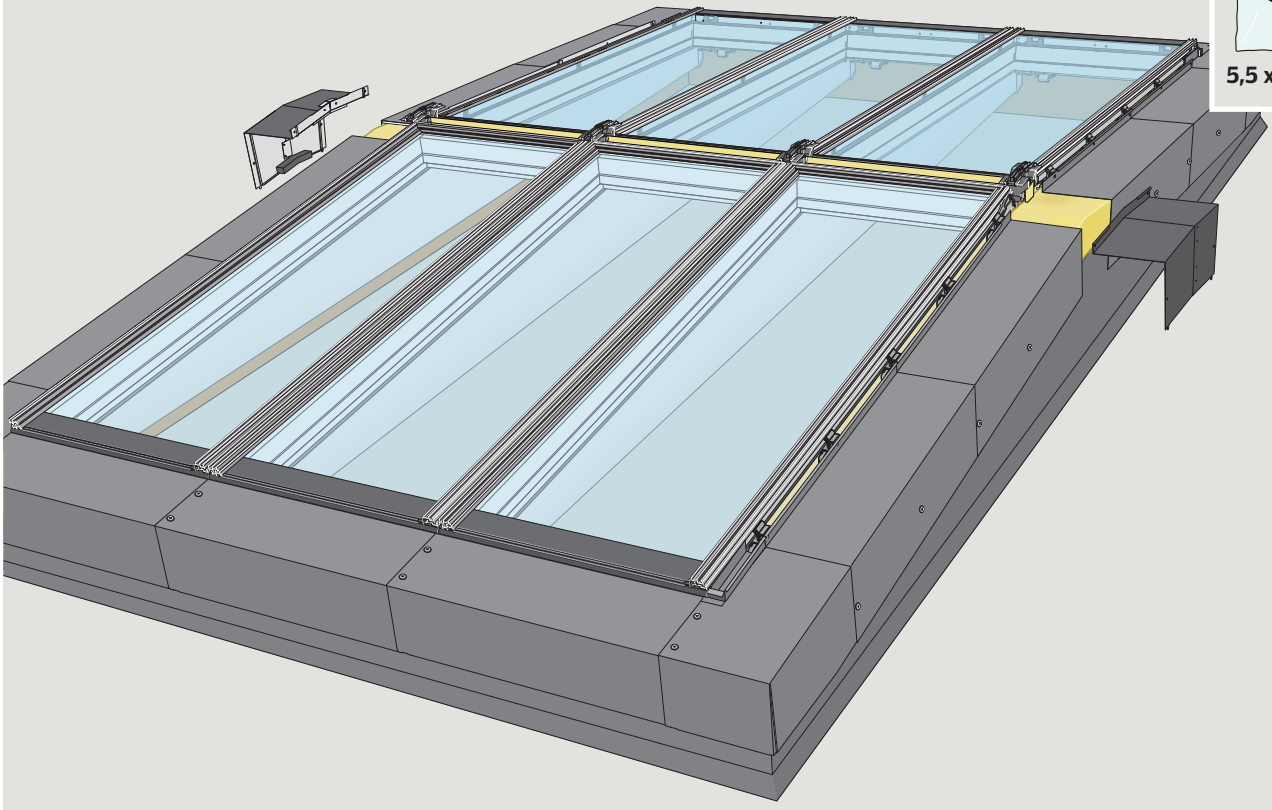

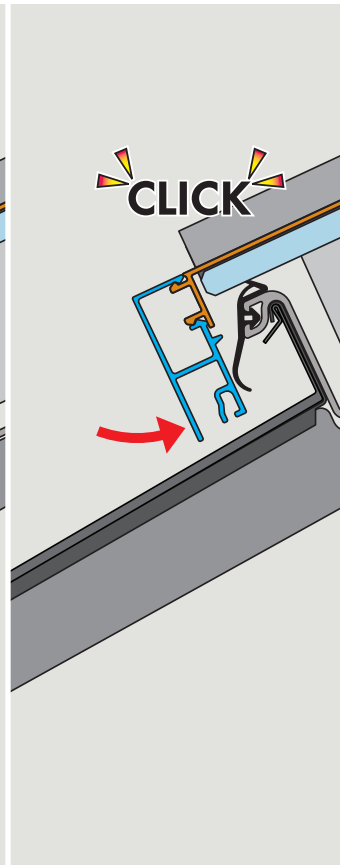
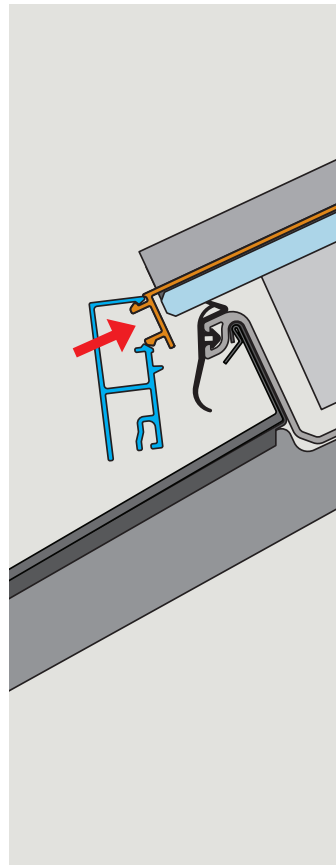
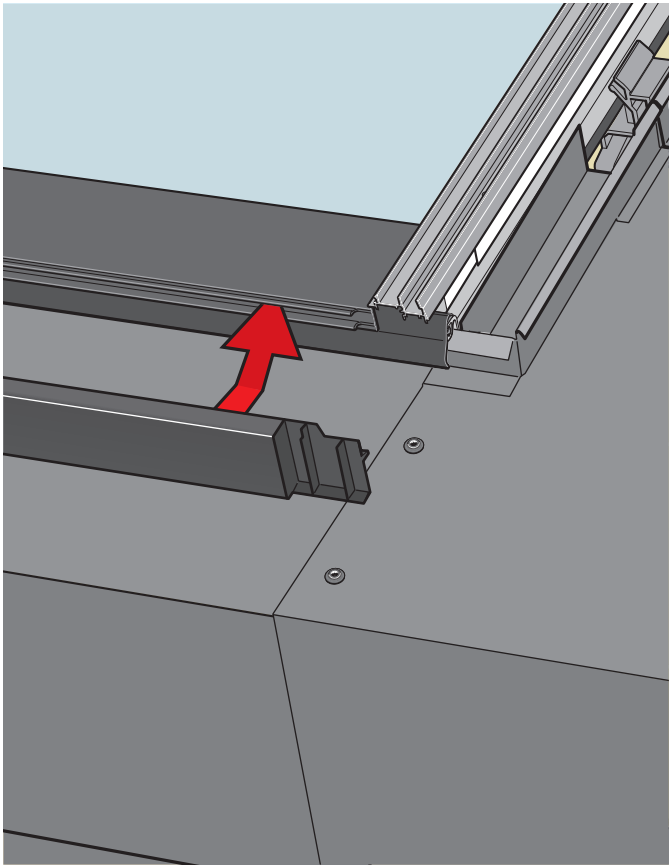
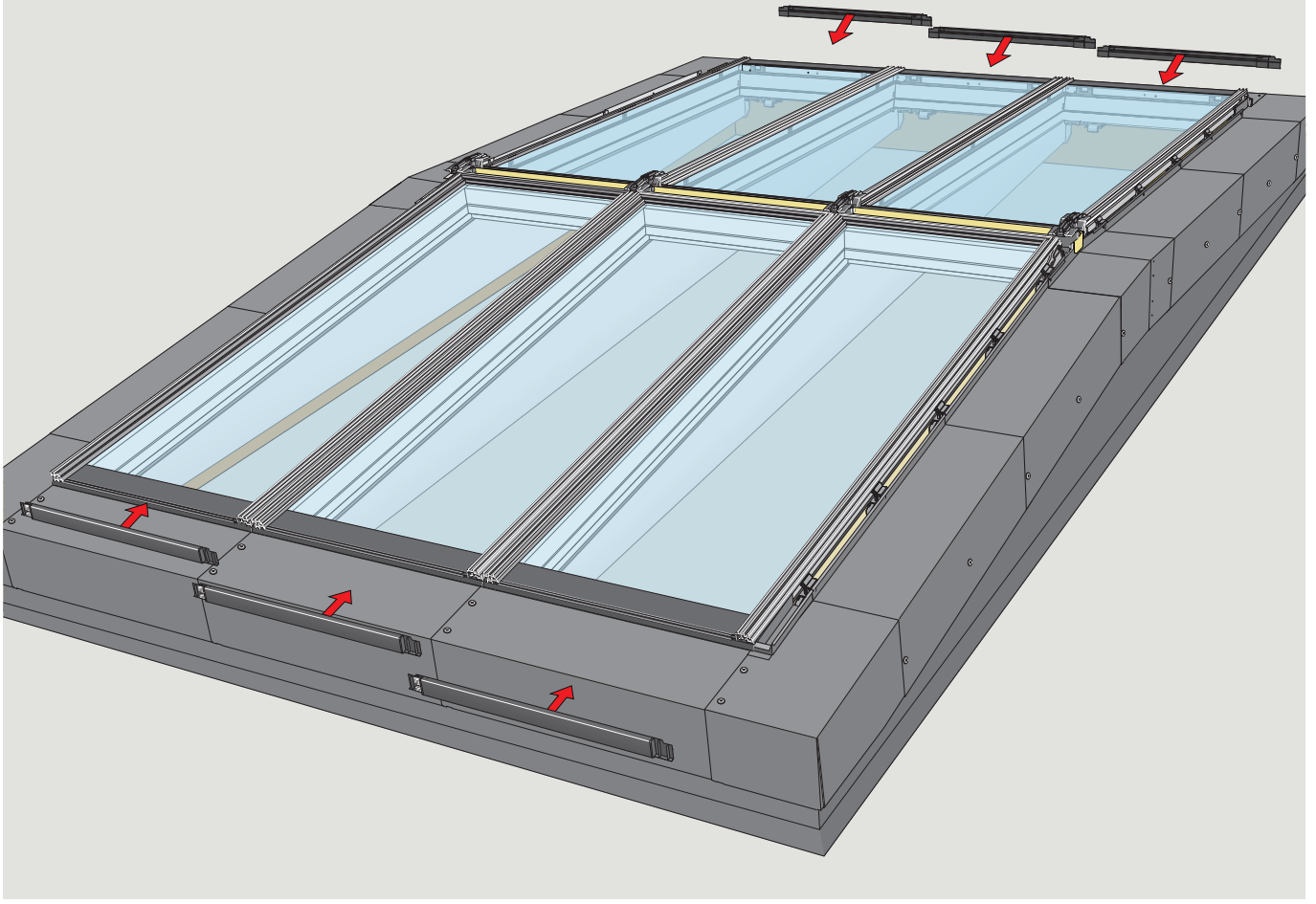

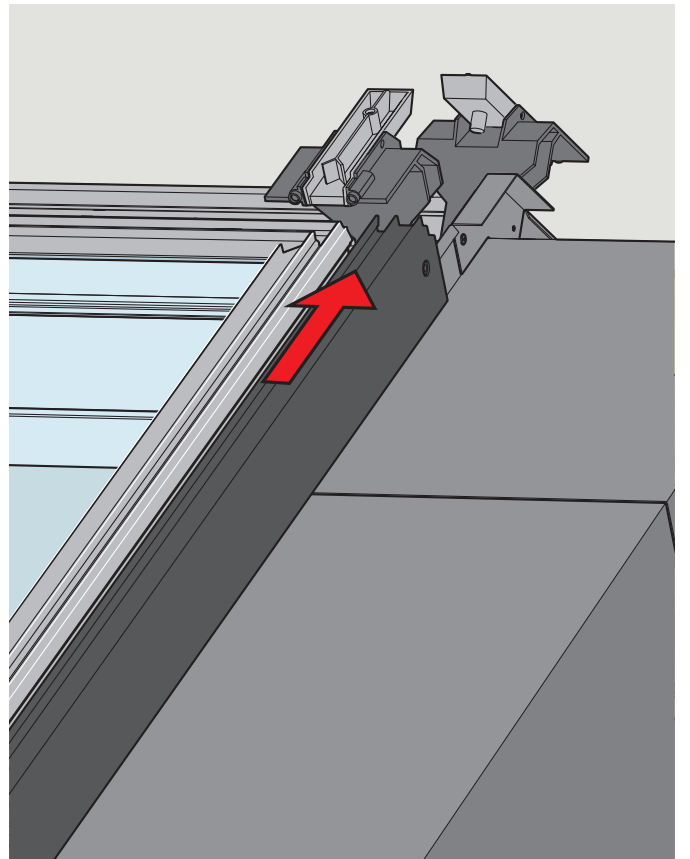
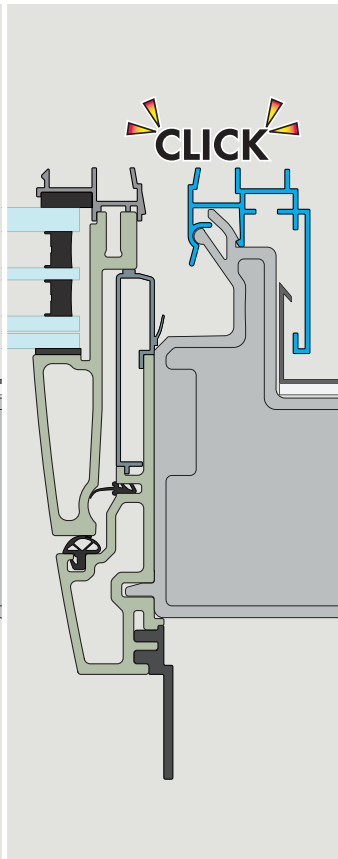
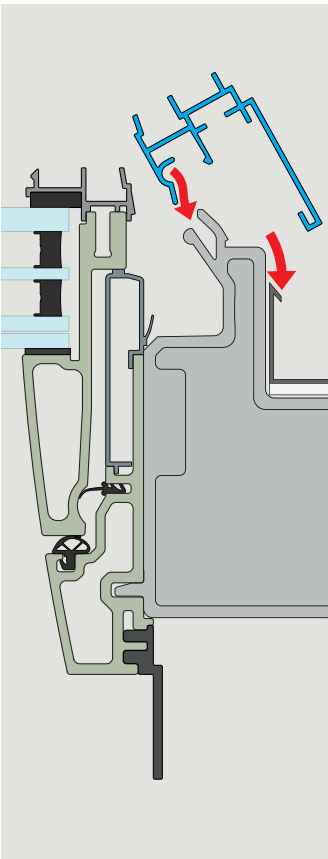
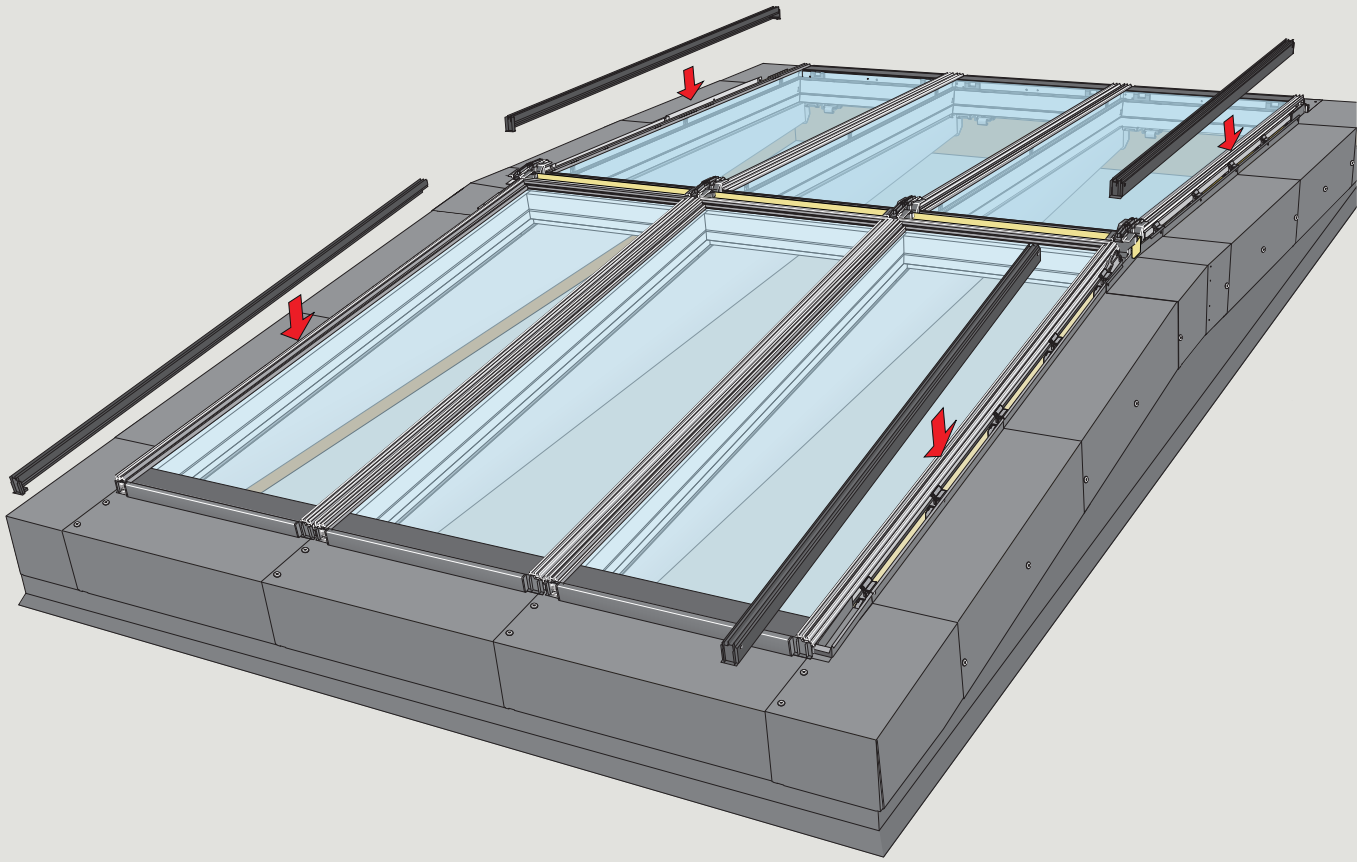



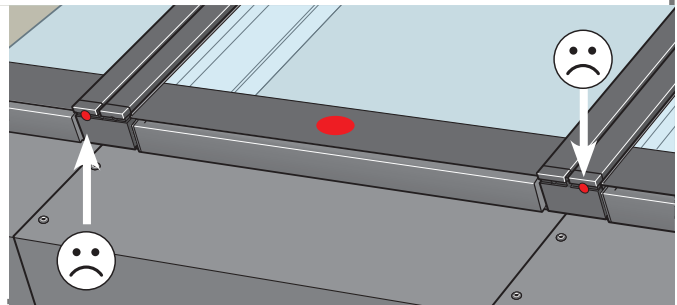
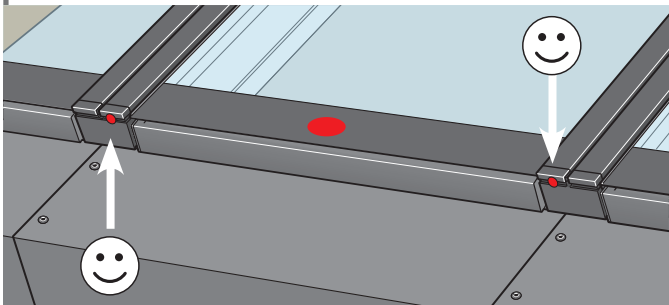
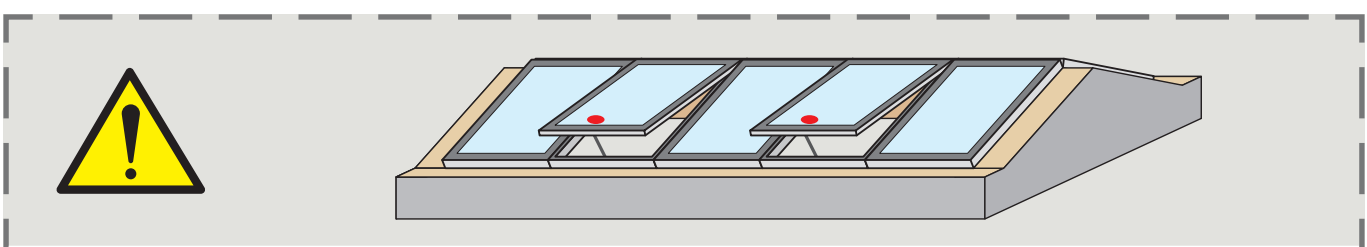
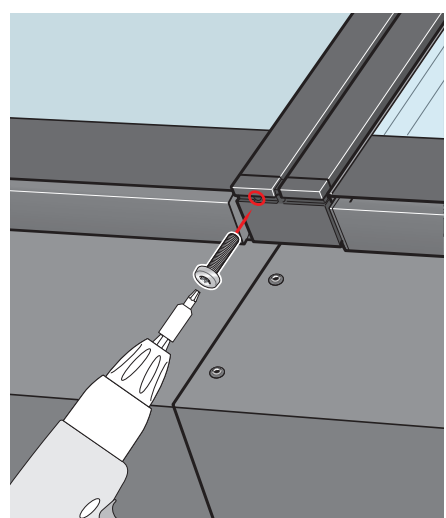
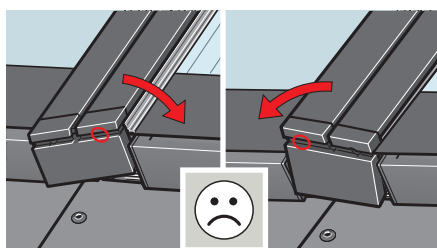
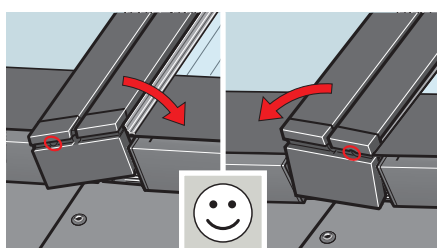
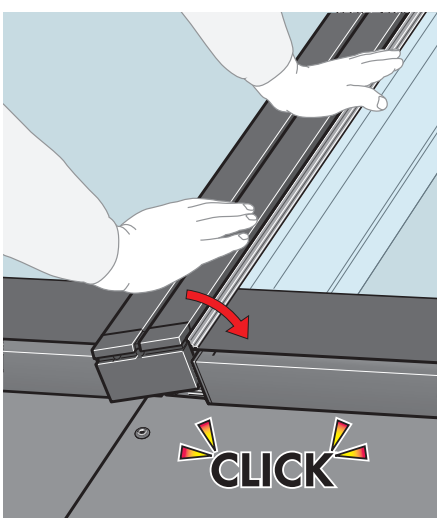
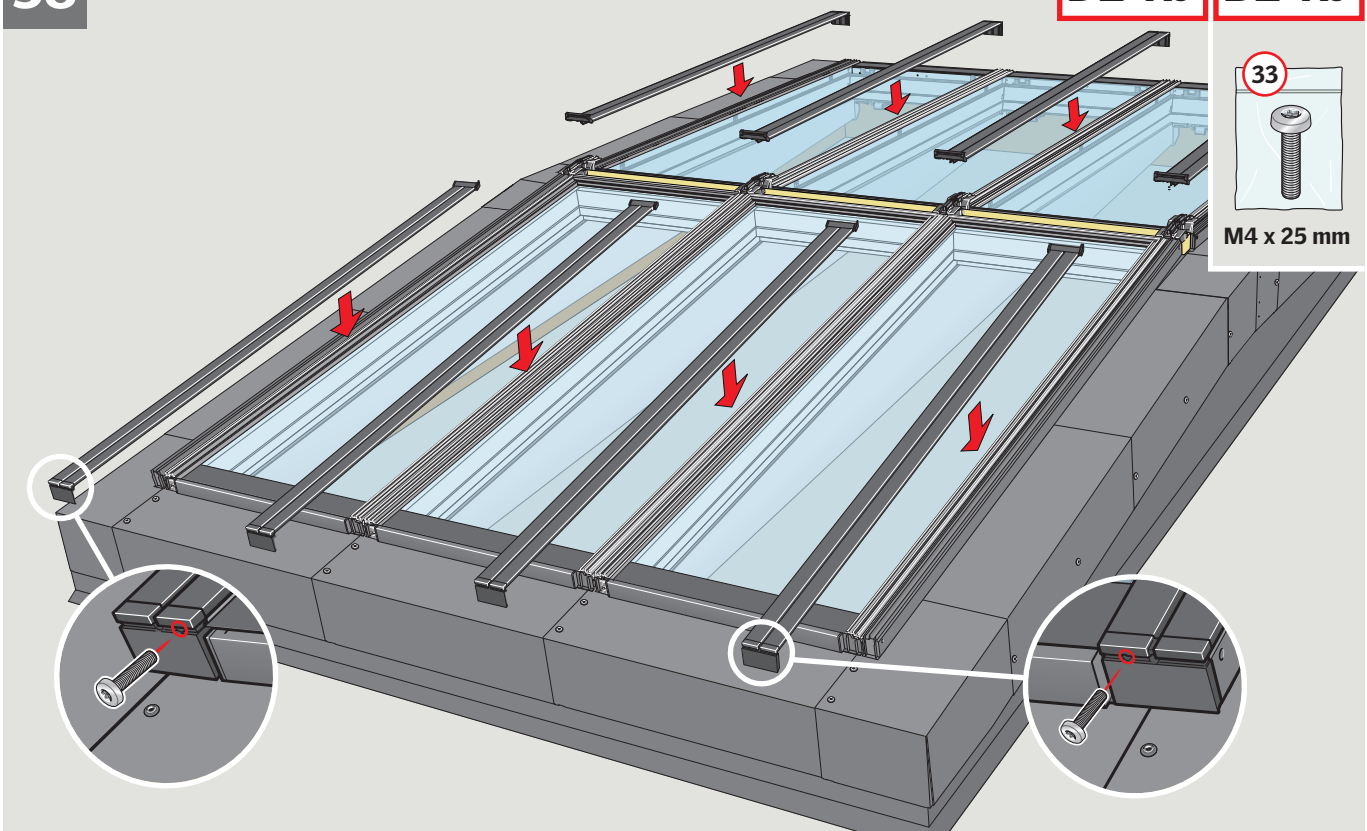

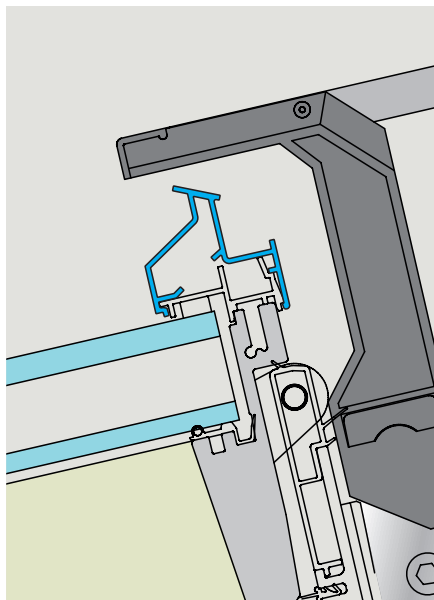
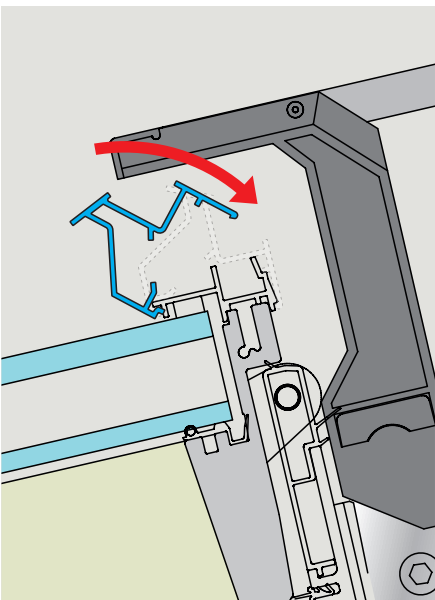
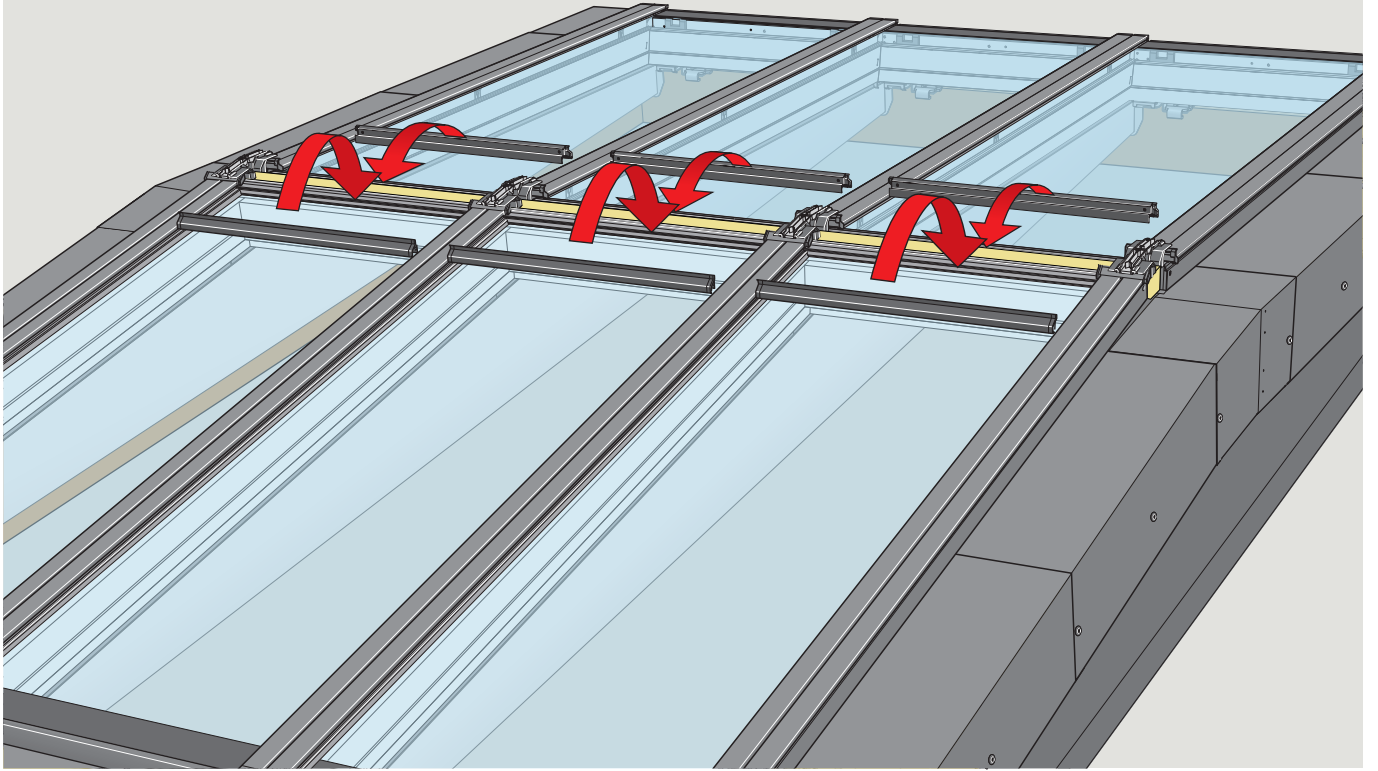

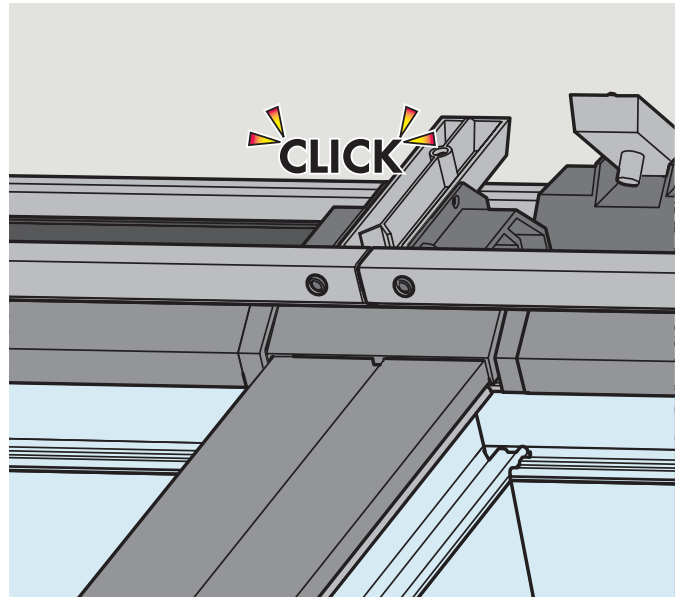
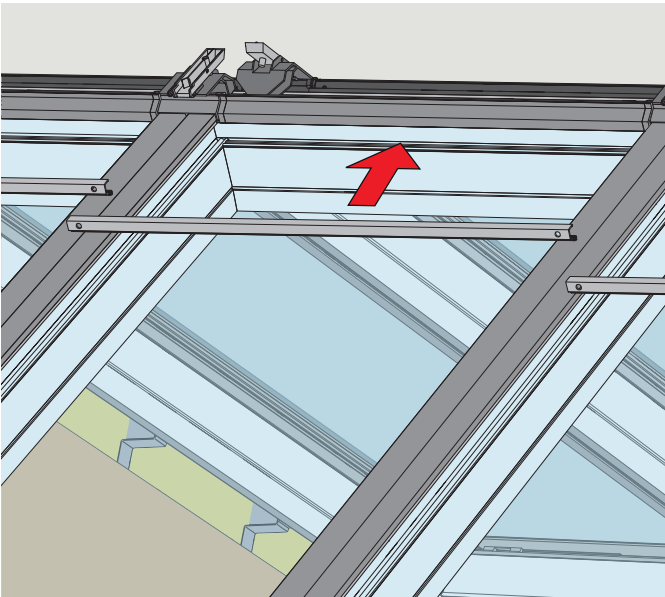
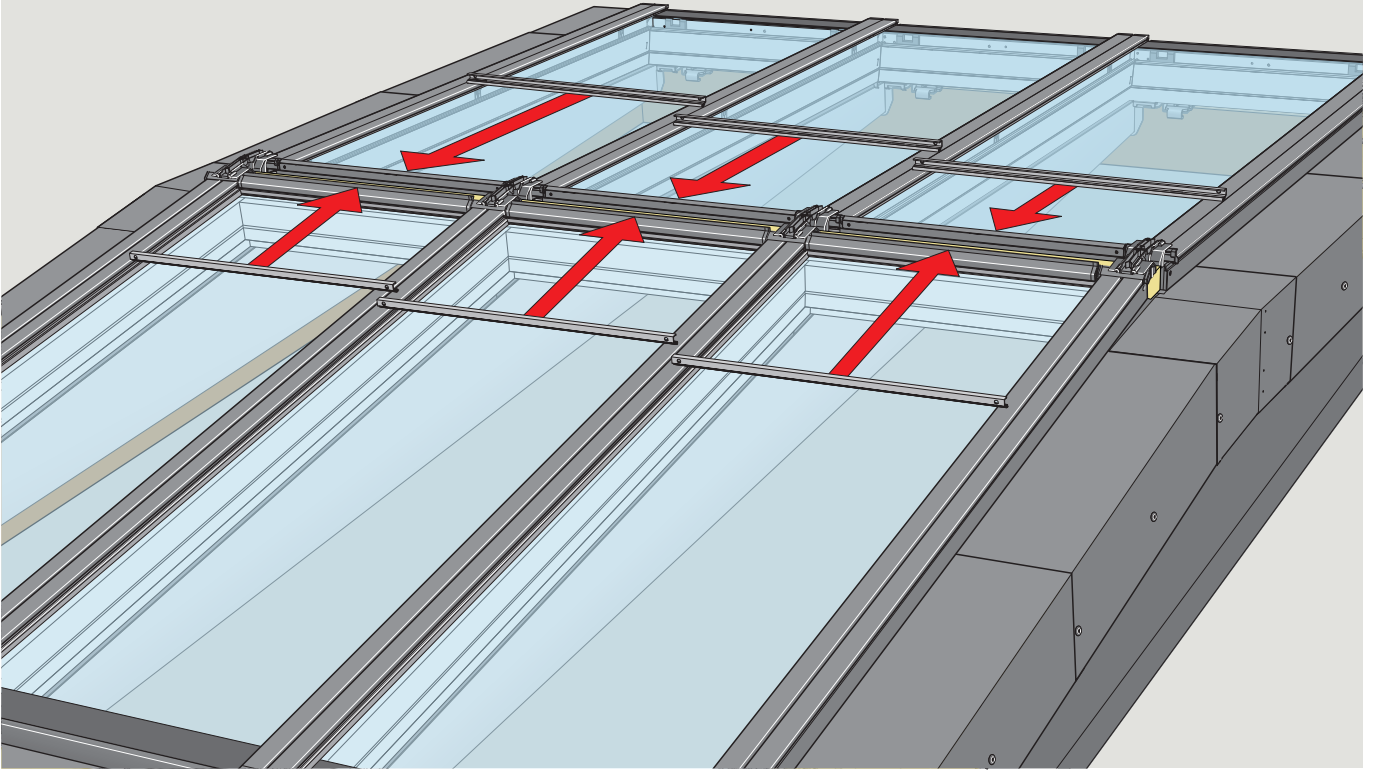

41

B2-R<sub>5°</sub>

D4-R<sub>5°</sub>



5,5 x 27 mm

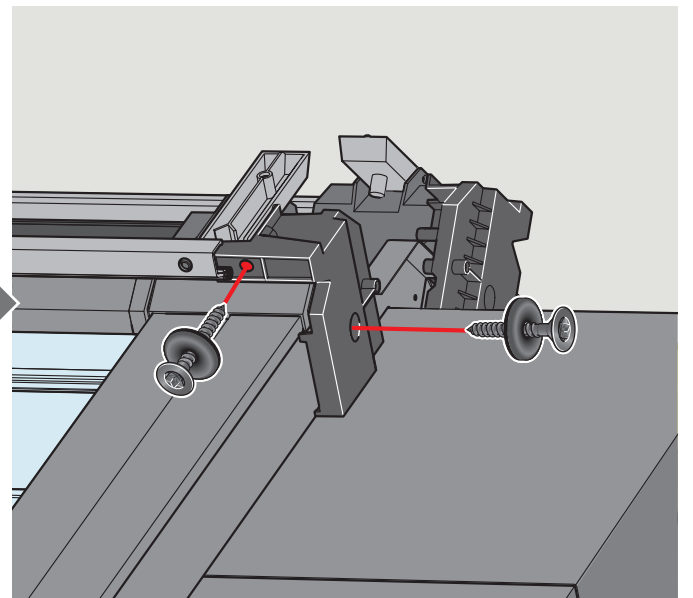
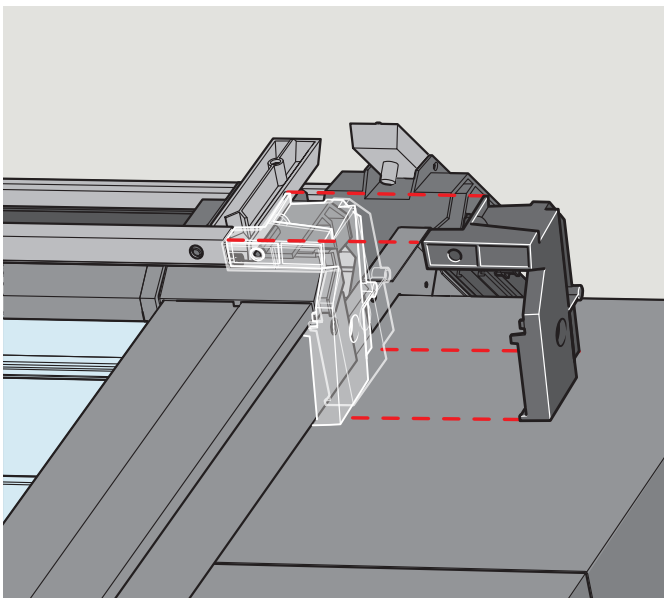
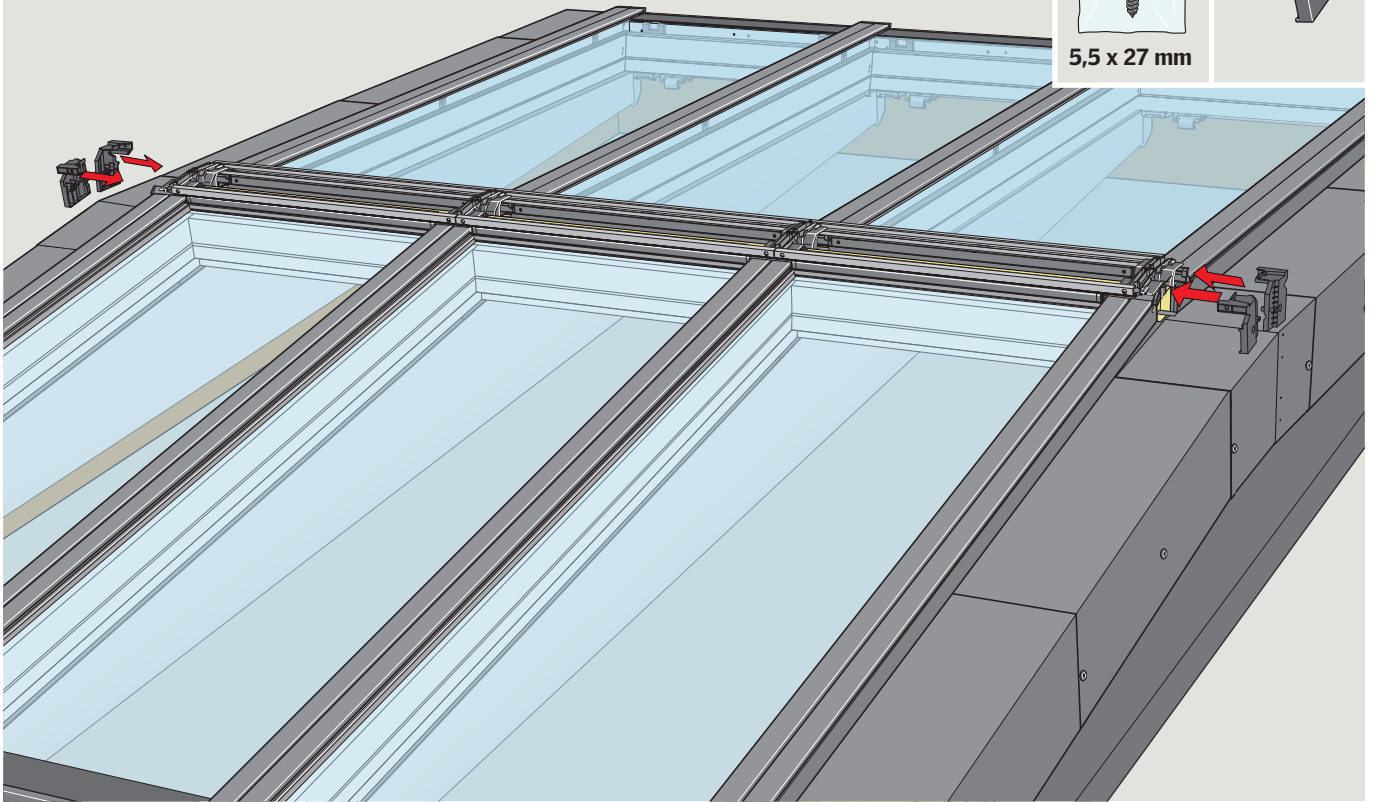
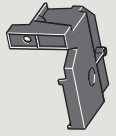

42

E1-R<sub>5°</sub>

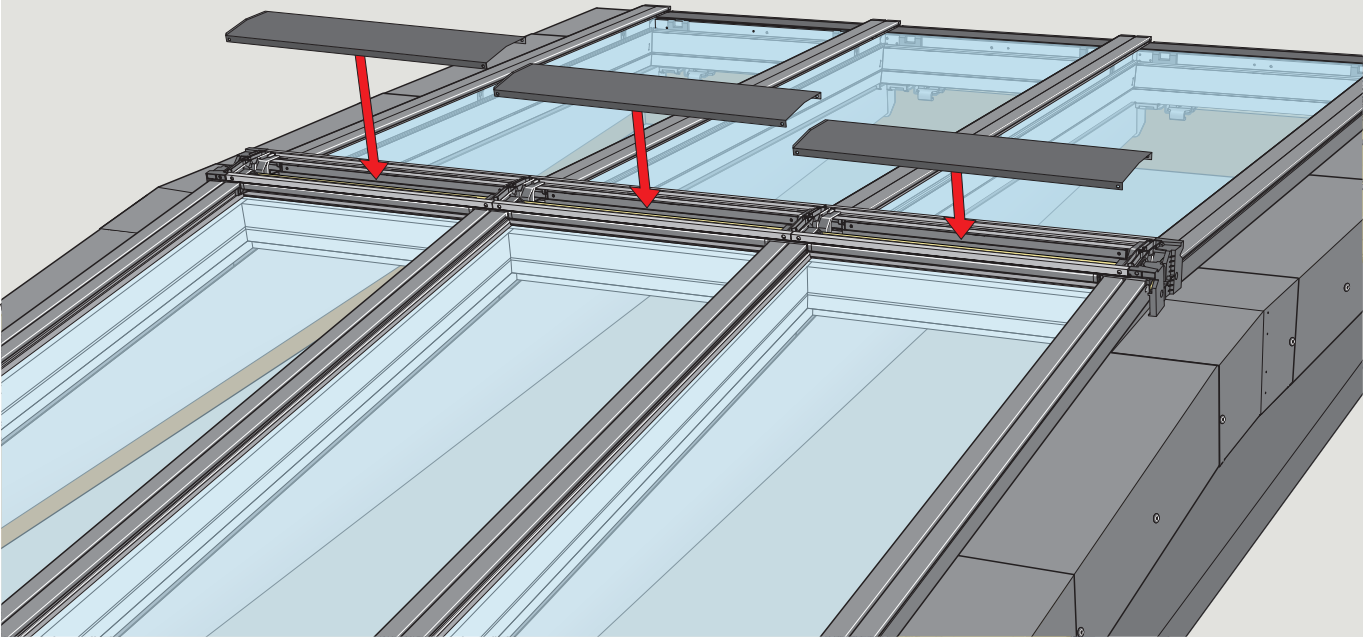

43

B2-R<sub>5°</sub>

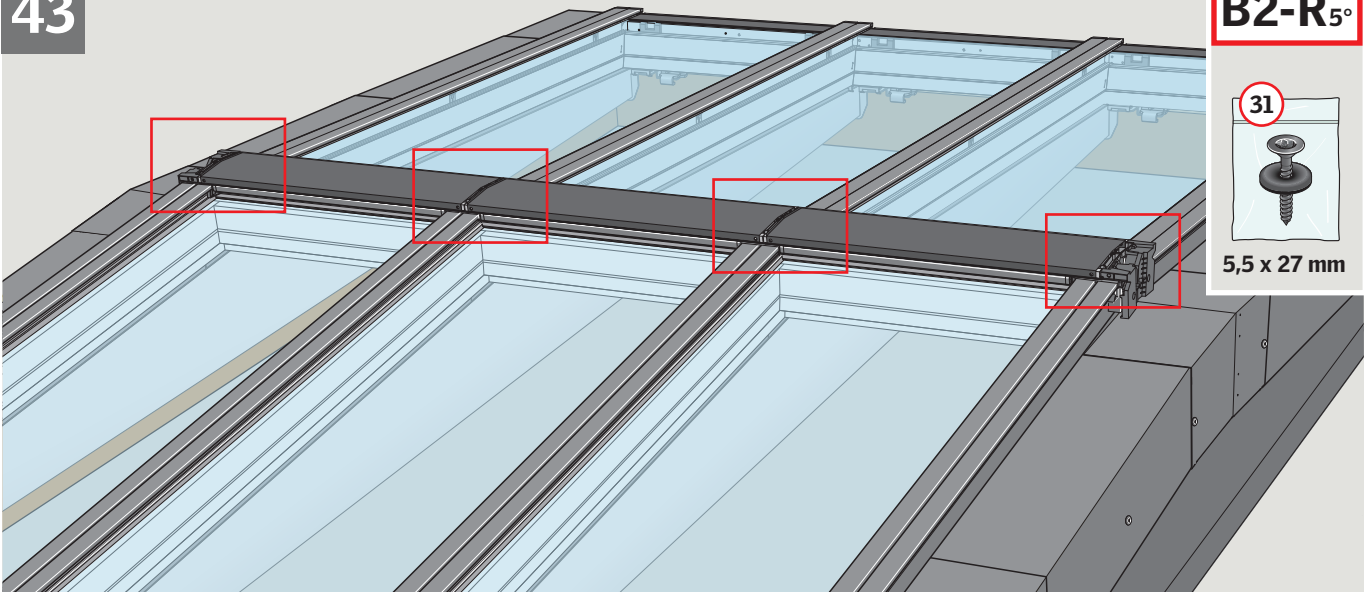

5,5 x 27 mm

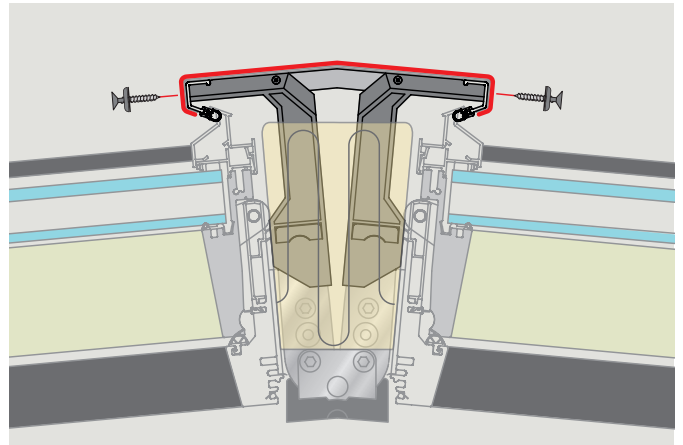
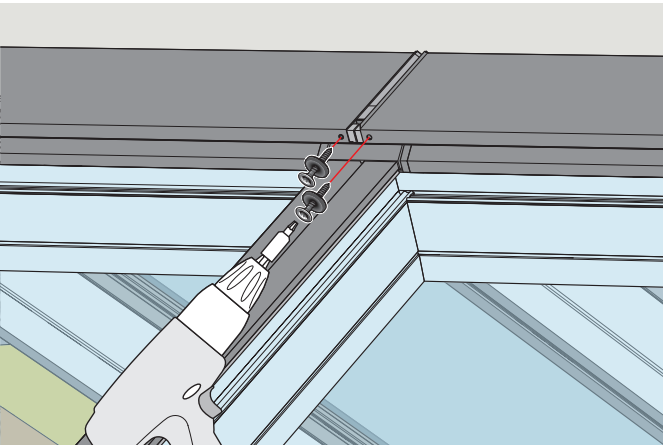

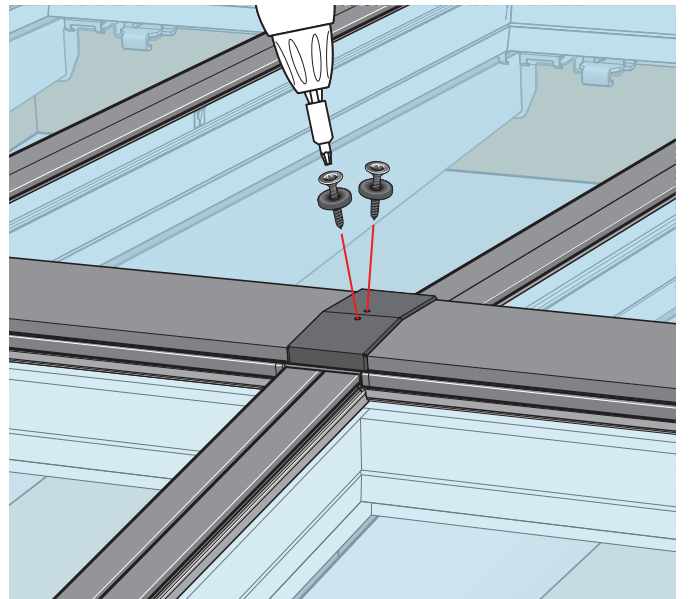
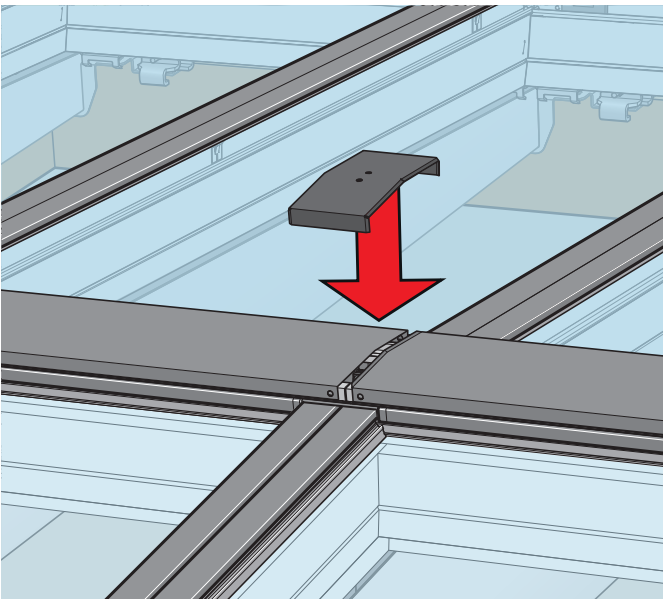
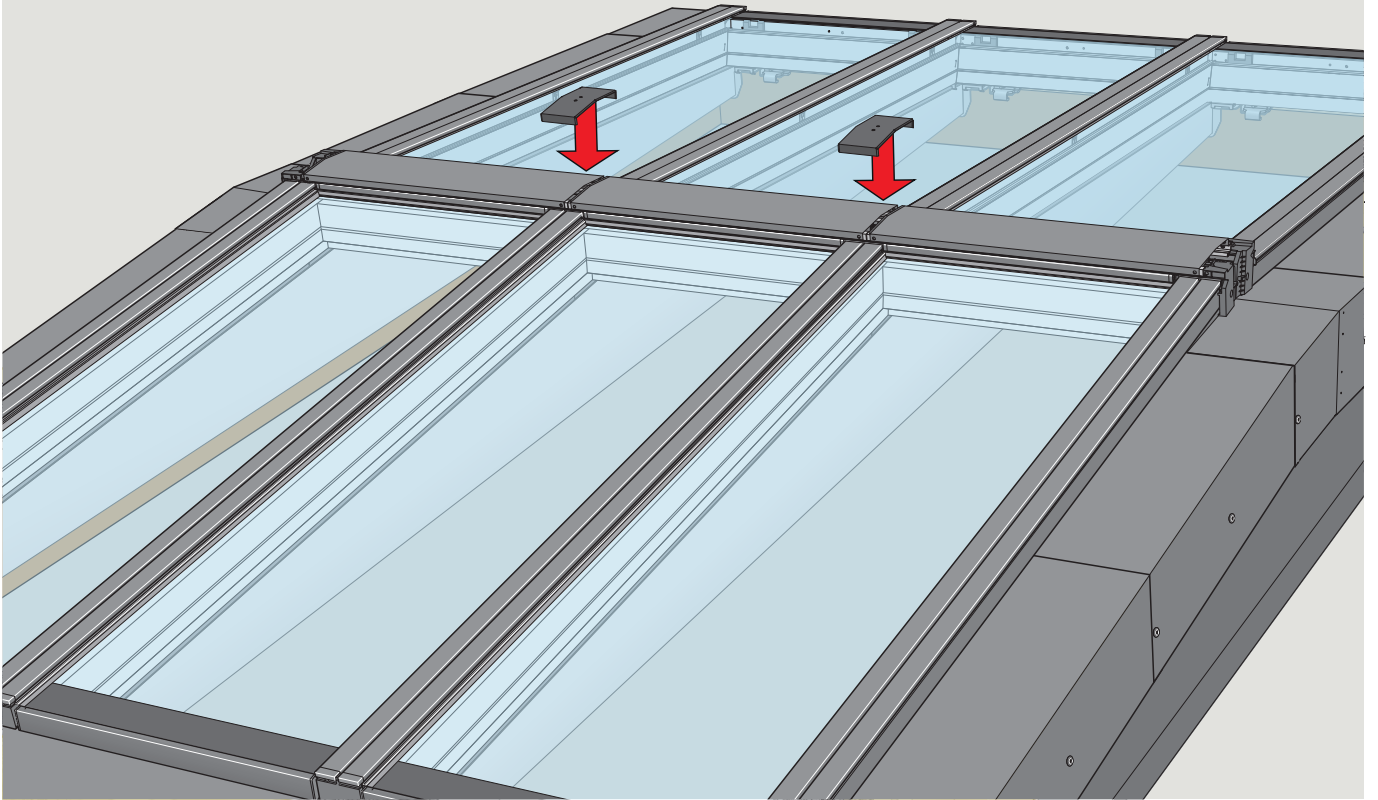

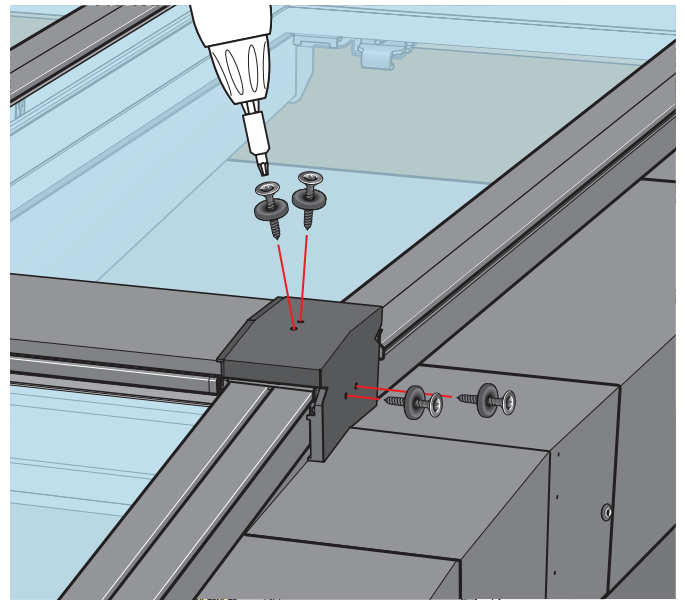
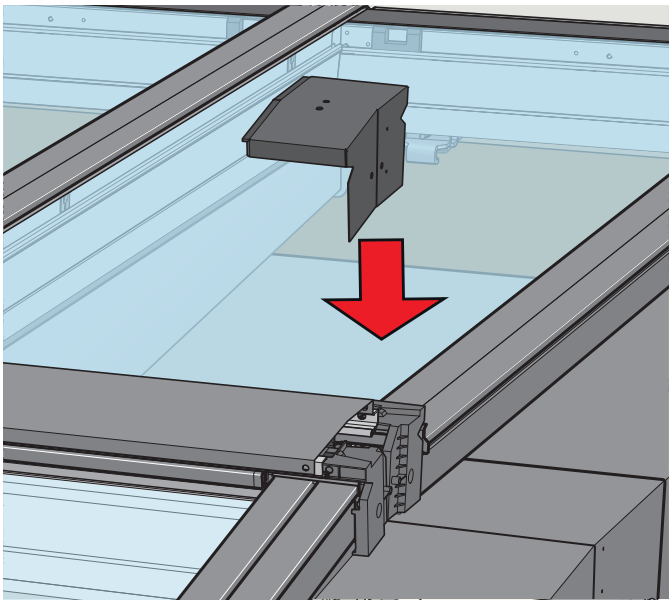
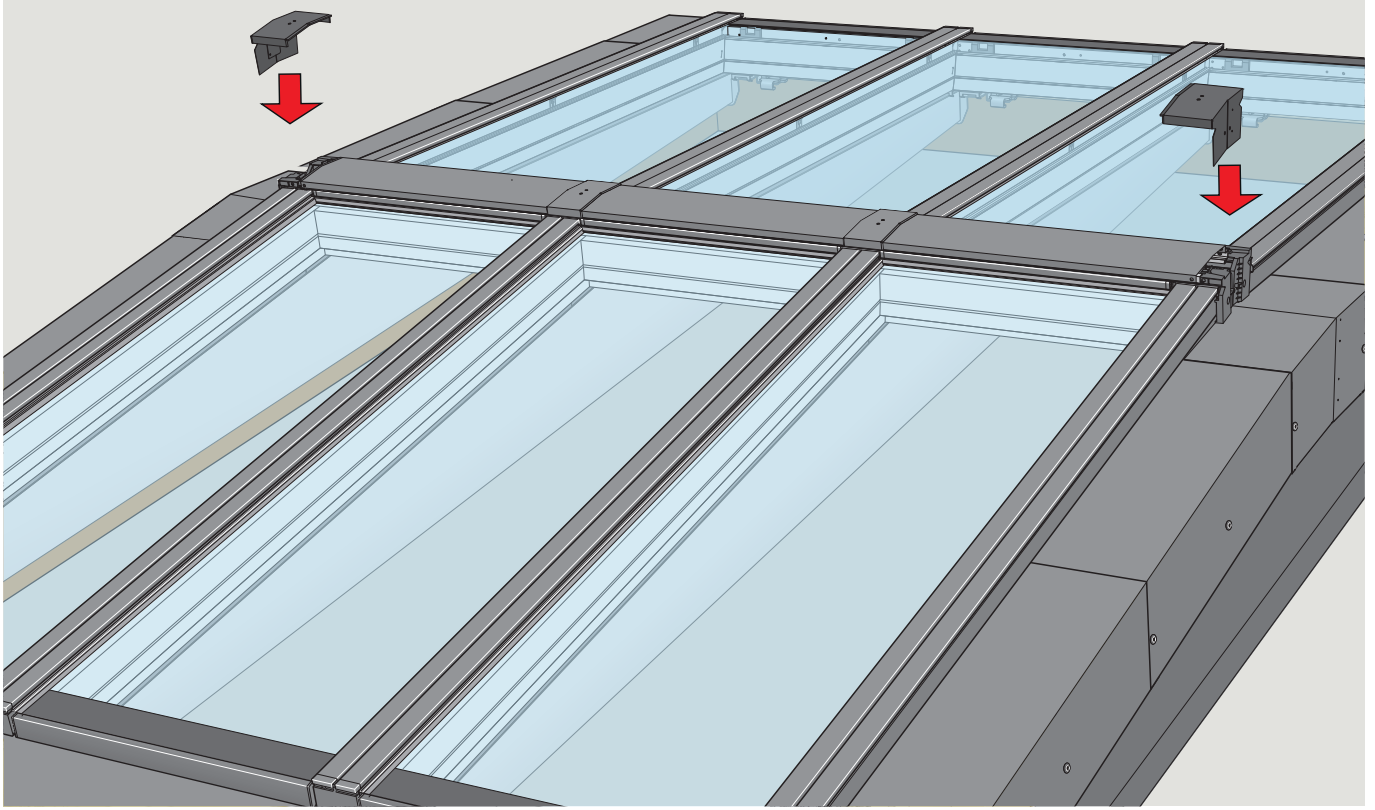

KCD

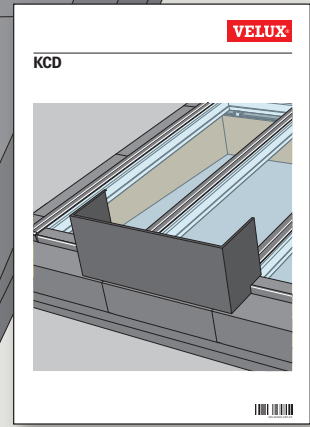

46

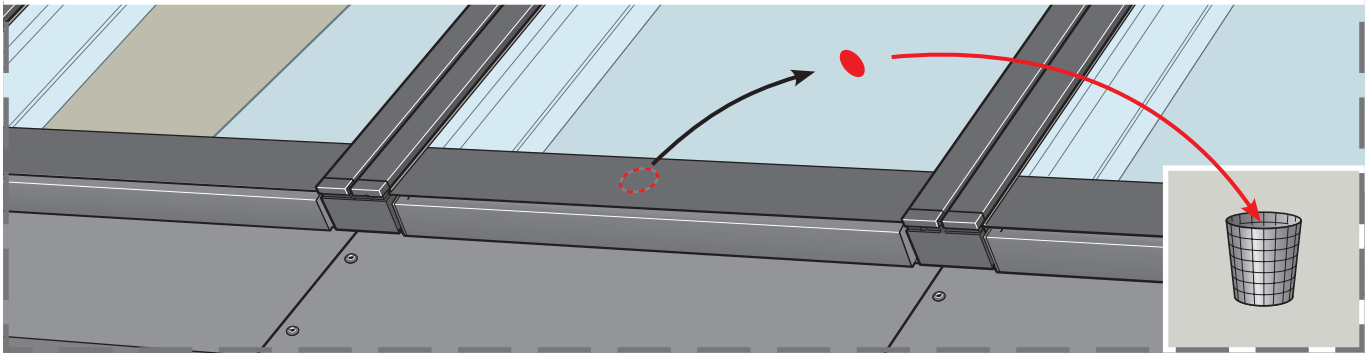
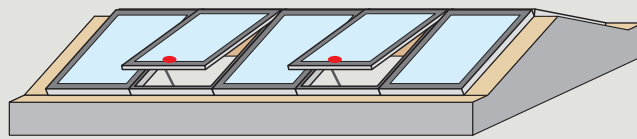

47

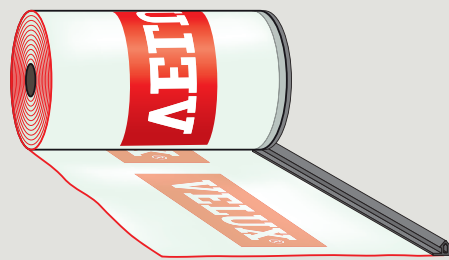

BCX

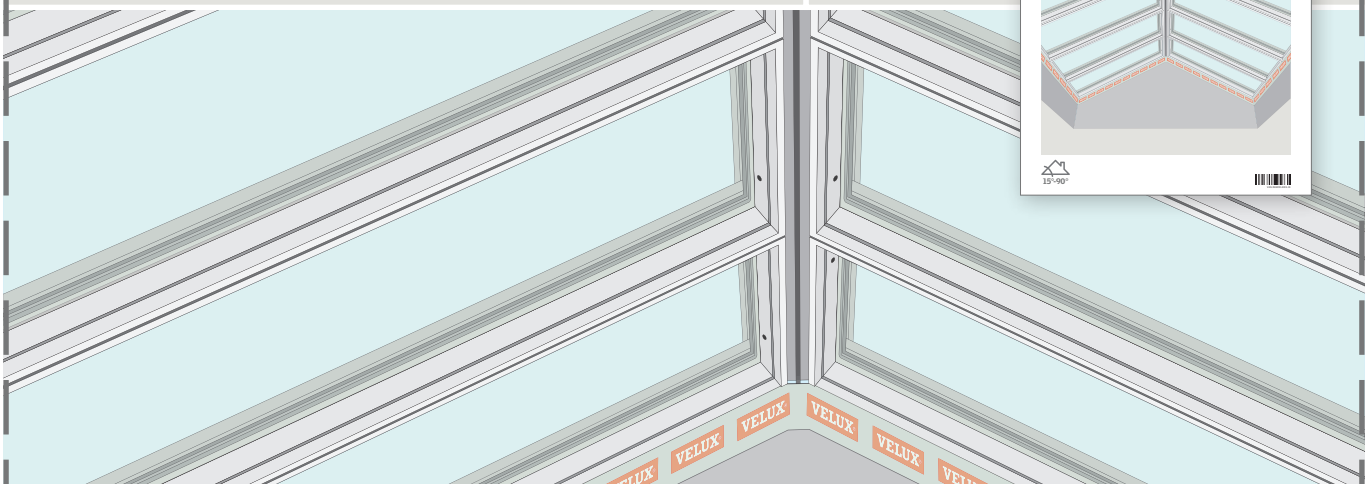
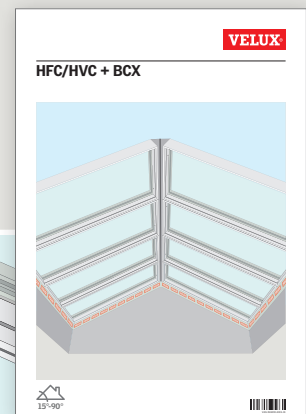









**AR:** VELUX Argentina S.A.  
348 4 639944

**AT:** VELUX Österreich GmbH  
02245/32 3 50

**AU:** VELUX Australia Pty. Ltd.  
1300 859 856

**BA:** VELUX Bosna i Hercegovina d.o.o.  
033/626 493, 626 494

**BE:** VELUX Belgium  
(010) 42.09.09

**BG:** ВЕЛУКС България ЕООД  
02/955 99 30

**BY:** Унитарное предприятие  
"ВЕЛЮКС Мансардные Окна"  
(017) 329 20 89

**CA:** VELUX Canada Inc.  
1 800 88-VELUX (888-3589)

**CH:** VELUX Schweiz AG  
062 289 44 45

**CL:** VELUX Chile SpA  
2 953 6789

**CN:** VELUX (CHINA) CO. LTD.  
0316-607 27 27

**CZ:** VELUX Česká republika, s.r.o.  
531 015 511

**DE:** VELUX Deutschland GmbH  
040 / 54 70 70

**DK:** VELUX Danmark A/S  
45 16 45 16

**EE:** VELUX Eesti OÜ  
621 7790

**ES:** VELUX Spain, S.A.  
91 509 71 00

**FI:** VELUX Suomi Oy  
0207 290 800

**FR:** VELUX France  
0821 02 15 15  
0,119€ TTC/min

**GB:** VELUX Company Ltd.  
01592 778 225

**HR:** VELUX Hrvatska d.o.o.  
01/5555 444

**HU:** VELUX Magyarország Kft.  
(06/1) 436-0601

**IE:** VELUX Company Ltd.  
01 848 8775

**IT:** VELUX Italia s.p.a.  
045/6173666

**JP:** VELUX-Japan Ltd.  
0570-00-8141

**LT:** VELUX Lietuva, UAB  
(85) 270 91 01

**LV:** VELUX Latvia SIA  
67 27 77 33

**NL:** VELUX Nederland B.V.  
030 - 6 629 629

**NO:** VELUX Norge AS  
22 51 06 00

**NZ:** VELUX New Zealand Ltd.  
0800 650 445

**PL:** VELUX Polska Sp. z o.o.  
(022) 33 77 000 / 33 77 070

**PT:** VELUX Portugal, Lda  
21 880 00 60

**RO:** VELUX România S.R.L.  
0-8008-83589

**RS:** VELUX Srbija d.o.o.  
011 20 57 500

**RU:** ЗАО ВЕЛЮКС  
(495) 640 87 20

**SE:** VELUX Svenska AB  
042/20 83 80

**SI:** VELUX Slovenija d.o.o.  
01 724 68 68

**SK:** VELUX Slovensko, s.r.o.  
(02) 33 000 555

**TR:** VELUX Çatı Pencereleri  
Ticaret Limited Şirketi  
0 216 302 54 10

**UA:** ТОВ "ВЕЛЮКС Україна"  
(044) 2916070

**US:** VELUX America LLC  
1-800-88-VELUX