

GRILLODUR® continuous rooflight flaps

VELUX®
Commercial

For high safety and indoor air quality

GRILLODUR® continuous rooflight flaps

- SHEV resp. ventilation flaps as arched or flat version
- single or double flap
- easy to install and maintain
- flaps for rooflight widths up to 7.0 m
- pneumatic or electrical operation (230V or 24V)
- approved according to DIN EN 12101-2 with CE marking
- lightweight aluminium construction with circumferential thermal separation
- U-value glazing up to 0.8 W/m²K

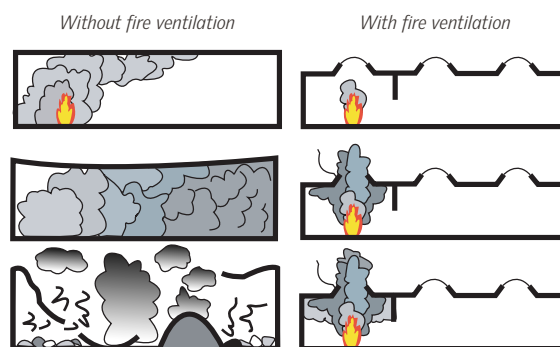

Example of the significance of a SHEV system in the event of fire in a building

The SHEV flaps for the arched daylight systems have been developed for combination with other control units to ensure an automatic smoke and heat exhaust system for the preventive fire protection. They should be positioned at the highest point of a daylight system in order to fulfill the function of preventive fire protection in an optimal way.

According to the latest findings, the smoke that immediately develops in case of fire is responsible for the threat to human life and health.

More than 80% of all fire victims die due to smoke poisoning. Moreover, a high percentage of material damage is caused by smoke.

What is fire prevention about?

By the use of smoke and heat exhaust systems it is possible to extract the life-threatening smoke, resp. to reduce its concentration due to dilution. This reduces the risk that the smoke spreads in the building so that emergency exits like e.g. corridors or staircases become impassable.



Prevention of smoke spread with SHEV systems

In case of fire, the SHEV flaps with help of their pneumatical or electrical drives in the upper part of the building and resp. also the air intake openings, can be opened automatically within a very short time.

Due to these openings rising smoke, heat and fumes can escape to the outside already in the early stage of fire. The air intake openings in the lower area ensure the necessary balance of air flow and strengthen the effect of thermal lift.

The wind deflectors required for the aerodynamics of the SHEV flap are an integral part of the flap system.

All our devices have been tested as SHEV systems according to DIN EN 12101-2 and therefore guarantee the best possible fire protection for your project!

GRILLODUR® SHEV flaps

Product advantages

- high-quality appearance
- U-value glazing up to 0.8 W/m²K
- opening devices freely selectable
- self-supporting construction
- superior safety
- easy to maintain

Opening devices

Flap type	System G9	System G19	System G29	System G24V
Single and double flap	Cylinder Ø 32 mm 850 mm stroke	Double stroke cylinder Ø 32 mm 850/200 mm stroke	Cylinder Ø 32 mm 850 mm stroke electrical motor 230V – 50HZ 300 mm stroke	Spindle drive with 850 mm stroke electrical motor 24V-4A
Function	SHEV	SHEV and ventilation	SHEV and ventilation	SHEV and ventilation

Arched single flap

Width B (mm)	Length A (mm)	Smoke exhaust surface A_{geo} (m ²)	Effective smoke exhaust surface A_s (m ²)
1,100	1,880	2,068	up to 1,551

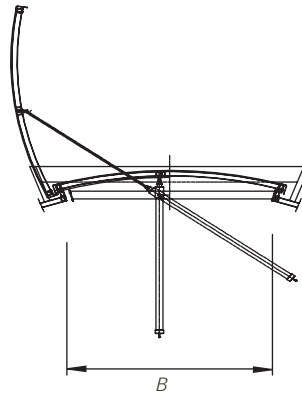

Optional:
electrical (G29 and G24V) or pneumatical (G19) ventilation

Arched double flap

Width B (mm)	Length A (mm)	Smoke exhaust surface A_{geo} (m ²)	Effective smoke exhaust surface A_s (m ²)
2,300	1,880	4,324	3,243

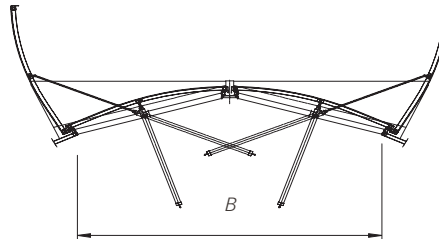

Optional:
electrical (G29) or pneumatical (G19) ventilation (only one half of flap ventable)

Single flap ridge turret 30°/45°

Width B (mm)	Length A (mm)	Smoke exhaust surface A_{geo} (m ²)	Effective smoke exhaust surface A_s (m ²)
980	1,880	1.84	1.20
1,100	1,880	2.07	1.34
1,350	1,880	2.54	1.65

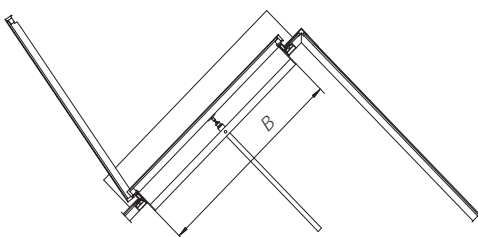

Note:
Optional: electrical (G29) or pneumatical (G19) ventilation

Double flap ridge turret 30°/45°

Width B (mm)	Length A (mm)	Smoke exhaust surface A_{geo} (m ²)	Effective smoke exhaust surface A_s (m ²)
980/980	1,880	3.68	2.21
1,100/1,100	1,880	4.14	2.48

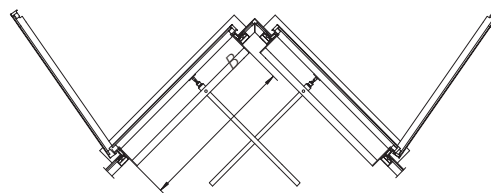

Note:
Optional: electrical (G29) or pneumatical (G19) ventilation (only one half of flap ventable)

GRILLODUR® DSG fall-through protection

- reliable protection on the roof
- certified according to GS-BAU-18
- quick and easy installation from the outside
- retrofittable with minimal effort

More safety during installation and maintenance of ventilation and SHEV flaps. The DSG fall-through protection for GRILLODUR® continuous rooflight flaps offers protection against falling of persons and larger objects. For flat and arched GRILLODUR® continuous rooflight flaps, the tried and tested catchment safety facility with its energy-absorbing grid structure ensures absolute safety in the flap area. The DSG fall-through protection is tested and certified by the BG BAU.



GRILLODUR® insect protection system

- effective and environmentally friendly
- weatherproof fiberglass fabric
- inconspicuous and permeable to air
- mesh size: approximate 1 mm

The GRILLODUR® insect protection system offers effective protection against the intrusion of insects, leaves and coarse soiling during daily ventilation. The insect protection system is used in hygienically demanding industries, especially in the food, beverage and pharmaceutical industries.

