

**VELUX®**

Commercial

# VELUX Modular Skylights

Technical Handbook

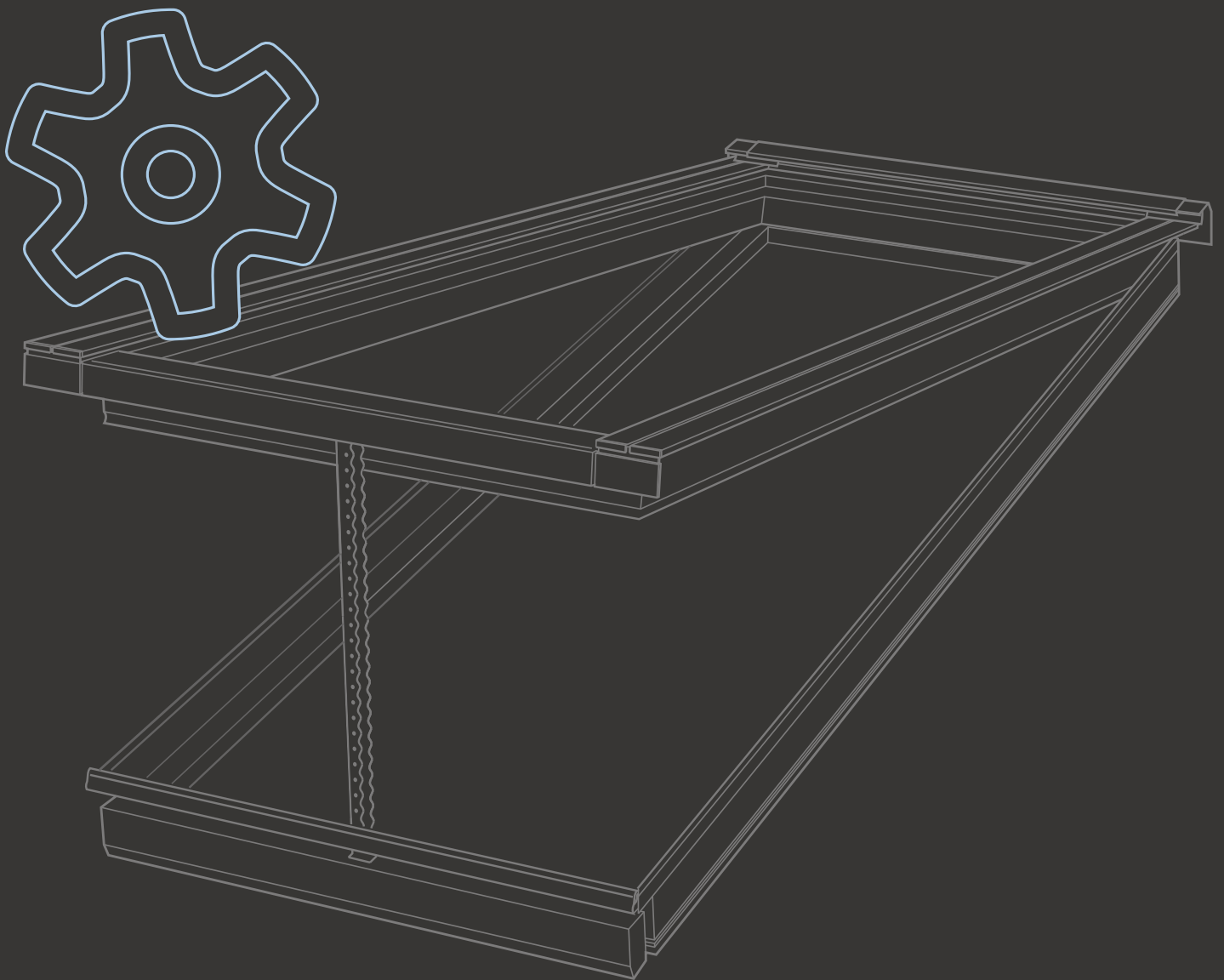





DZNE: German Center for Neurodegenerative Diseases, Germany, 2016  
Ridgelight at 5° with Beams  
Photographer: STORM Production









## VELUX Modular Skylights

---

VELUX Modular Skylights are sash-frame constructed single roof windows with a high-insulating glazing unit. The modules are available as both fixed and venting skylights. All individual skylights are delivered as prefabricated modules with dedicated factory finished flashings to ensure watertightness in every solution.

VELUX Modular Skylights roof windows are CE-marked in accordance with the harmonized standard EN 14351-1 – Windows and doors.

Fire resistant modules are CE-marked in accordance with the EAD 220116-00-0401 of 2018-12 as relevant harmonized technical specification and the essential characteristics are expressed in accordance with the ETA-19/0027 of 2019-03-11.

The self-supporting Ridgelights are CE-marked in accordance with the European Assessment Document EAD 220013-01-0401 of 2017-03 as relevant harmonized technical specification.

The load bearing capacity performance of the self-supporting Ridgelights is expressed in the European Technical Assessment ETA 17/0476 of 2019-01-28.

In addition, the skylight modules have been tested and approved in accordance with EN 12101-2 – Smoke and heat control systems Part 2: Specification for natural smoke and heat exhaust ventilators.

VELUX Modular Skylights has a reference service life of 30 years in accordance with EN 17213.

This technical handbook for VELUX Modular Skylights describes the product characteristics and performance of the skylight module together with sun screening and control system.

For real life case studies and inspiration, please refer to: [veluxcommercial.com](http://veluxcommercial.com)



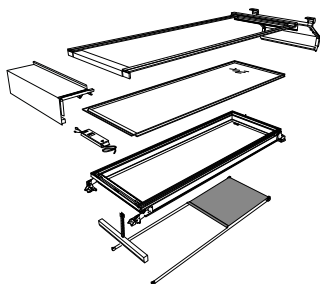

**Modular System 7**

- Skylight module 8
- Functions & sizes / Size grid 8
- How to measure the modules 10
- Solutions 12
- Module – main components 16
- Module – electrical components 17
- Frame & sash 18
- Cladding & flashing 22
- Glazing unit 24
- Brackets & hinges 28
- Module – assembled 30
- Sub-construction 32
- Vapour barrier connection strip / Products for swimming pool environments 34
- Chain actuator 36
- Control system 37
- Roller blind 38
- Beam for Ridgelight at 5° 40
- Wind deflector for smoke ventilation modules 42
- Data plate 43

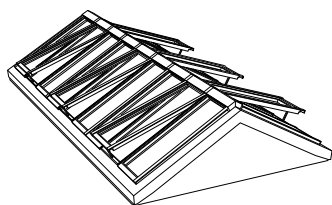

**Solutions 45**

- Quick overview of skylight solutions vs. roof constructions 46
- Longlight 5-30° 54
- Wall-mounted Longlight 5-45° 56
- Northlight 25-90° 58
- Ridgelight 25-40° 60
- Ridgelight at 5° with Beams (Horizontal beam with rectangular profile) 62
- Ridgelight at 5° with Beams (Parallel beam with curved profile) 64
- Step Longlight 5-25° 66
- Step Wall-mounted Longlight 5-25° 68
- Step Ridgelight 25° 70
- Step Ridgelight 5-25° on Girder 72
- Atrium Longlight 74
- Atrium Ridgelight & Atrium Ridgelight at 5° with Beams 76

Skylight Technical Data and Order-Code (see page 10) - EN 12250-2:2000			
Glazing area	EN 12250-2:2000	A <sub>g</sub> (m <sup>2</sup> )	0.16 - 1.07 depending on size
Perforated area	EN 12250-2:2000 Annex B	A <sub>h</sub> (m <sup>2</sup> )	0.05 - 0.89 depending on size
Perforated ratio	EN 12250-2:2000 Annex B	CR	0.40 - 1.00 depending on size
Frame load (N/m)	EN 12250-2:2000 Annex C	W <sub>l</sub> (N/m)	750 N/m
Wind load (N/m)	EN 12250-2:2000 Annex C	W <sub>l</sub> (N/m)	5000 N/m
Low ambient temperature (°C)	EN 12250-2:2000 Annex C	T <sub>l</sub> (°C)	-10
Windability (N/m <sup>2</sup> ) (external pressure)	EN 12250-2:2000 Annex C	W <sub>e</sub> (N/m <sup>2</sup> )	1000 - 3000
Windability (N/m <sup>2</sup> ) (internal pressure)	EN 12250-2:2000 Annex C	W <sub>i</sub> (N/m <sup>2</sup> )	600
Reaction to fire (see EN 13501-1)	EN 13501-1	Class	B-s1-d0 Per 1000 mm <sup>2</sup> or B-s1-d0 Per 100 mm <sup>2</sup>

**Product Data 79**

- Skylight module 80
- Glazing unit 98
- Frame & sash 101
- Cladding & flashing 101
- Interior colours frame & sash / Exterior colours cladding & flashing 102
- Vapour barrier connection strip 104
- Chain actuator 104
- Control system 106
- Roller blind 107
- Beam for Ridgelight at 5° 110
- Water pressure & drainage 111
- Resistance to wind load 112
- Reaction to fire 114
- Resistance to fire 116
- External fire performance 118
- Watertightness 120
- Air permeability 122

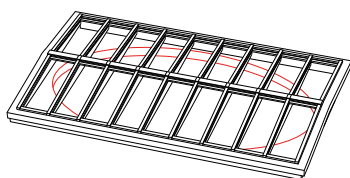

**Additional Solutions 125**

- Shaped solution with adaption of lining 126
- Shaped solution with oval lining 126
- Asymmetric Ridgelight 127
- Ridgelight on Girder 127
- Infill panel 128
- Skylight modules with photovoltaic glazing units 128
- Sun screening – electrochromic glass 129
- Sun screening – external awning blinds 129

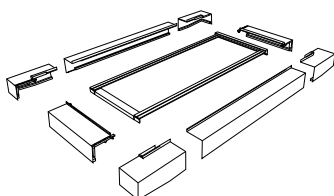

**Product Codes 131**

- Modular Skylight – code structure 132
- Roller blinds – code structure 133
- Product label – code structure 133
- Flashings – code structure 134







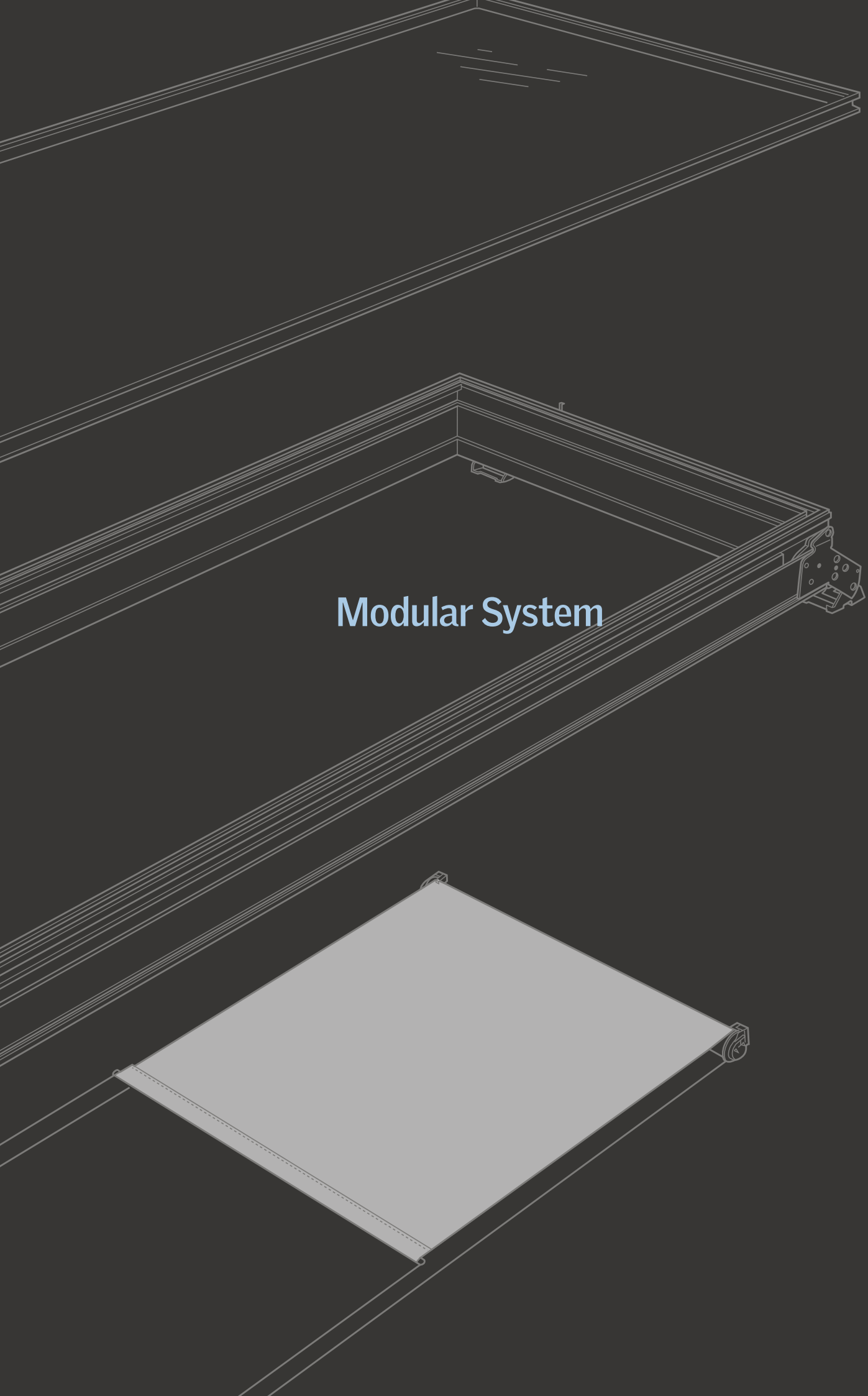

**Modular System**



## Skylight module

---

CE-marked VELUX Modular Skylights can be used in any building where the national, local and individual building requirements allow the use of skylight modules. Given the aesthetics and advanced performance of the products, VELUX Modular Skylights are commonly used in heated buildings and primarily in projects that support light

commercial interests, e.g. hospitals, schools, shopping centres, offices, museums etc. However, all buildings that have a suitable structure and are large enough to host an installation, will support VELUX Modular Skylights.

## Functions & sizes

---

VELUX Modular Skylights are available as fixed and venting modules. Due to a hidden chain actuator, the fixed and venting modules appear to be visually identical in closed position. It is not possible to install two venting modules next to each other.

Venting modules are top-hung and can be used for comfort ventilation, and in addition, certain types are approved for smoke ventilation in accordance with EN 12101-2.



---

**HFC**

Fixed skylight module.



---

**HFS**

Fire resistant module.



---

**HVC-C**

Motorized comfort venting skylight module.  
Actuator chain stroke 260 mm.

---

**HVC-A**

Motorized smoke venting skylight module.  
Actuator chain stroke up to 700 mm, which opens in less than 60 seconds.  
Only open system actuator available.

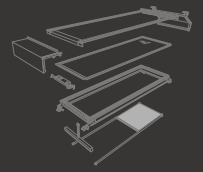

## Size grid

Standard size.

Semi-Standard, functional limitations may apply.

Non-Standard, available for certain projects.

### Fixed modules



mm	675	750	800	900	1000
600	±Δ	±Δ	±Δ	±Δ	±Δ
800	Φ	Φ	Φ	Φ	Φ
1000	Φ	Φ	Φ	Φ	Φ
1200					
1400					
1600					
1800					
2000					
2200					
2400					
2600	*	*	*	*	*
2800	*	*	*	*	*
3000	*	*	*	*	*

### Comfort ventilation

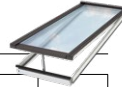

mm	675	750	800	900	1000
600					
800	Φ	Φ	Φ	Φ	Φ
1000	Φ	Φ	Φ	Φ	Φ
1200					
1400					
1600					
1800					
2000					
2200					
2400					
2600	* P	* P	* P	* P	* P
2800	* P	* P	* P	* P	* P
3000	* P	* P	* P	* P	* P

### Smoke ventilation



mm	675	750	800	900	1000
600					
800	○	○	○	○	○
1000	○	○	○	○	○
1200	○	○	○	○	○
1400	○	○	○	○	○
1600	○	○	○	○	○
1800	○	○	○	○	○
2000	○	○	○	○	○
2200	○	○	○	○	○
2400	○	○	○	○	○
2600	* ○ P	* ○ P			
2800	* ○ P				

- \* Module height above 2400 mm is delivered with an extra strong glazing unit only.
- Δ No roller blinds available.
- Only open system actuator available.
- ± Not available for Ridgelight.
- P Not possible as start/end modules.
- Φ Roller blinds must be pre-mounted or installed by a VELUX technician.

For size specific load capacity, please contact us.  
 If roller blinds are requested for smoke venting modules or fire resistant modules, please refer to local fire authorities for permission.  
 NB: Roller blinds for smoke venting modules or fire resistant modules cannot be pre-mounted.  
 Wind deflector KCD 0080 is not available for sizes above 2400 mm.



## How to measure the module

---

Width and height of the modules are determined by the exterior dimensions of the frame – not the measurements of the cladding, flashing or brackets.



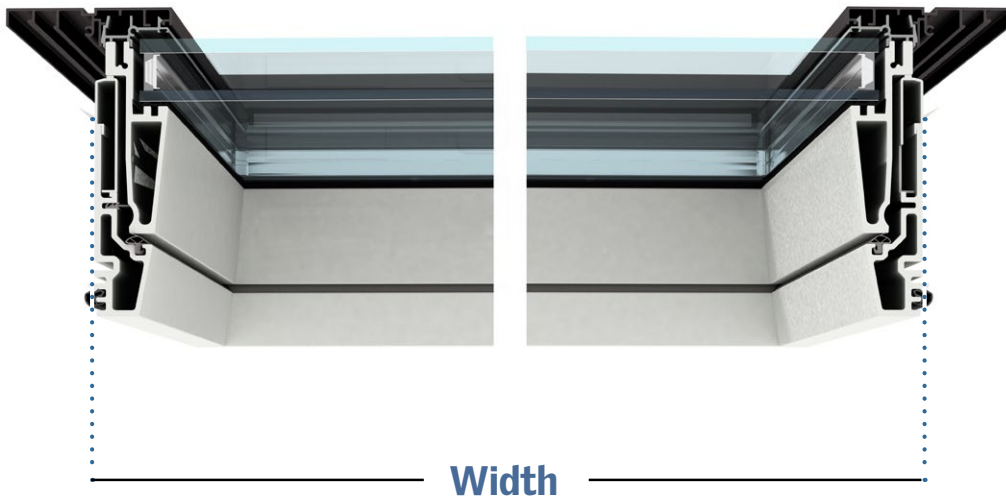
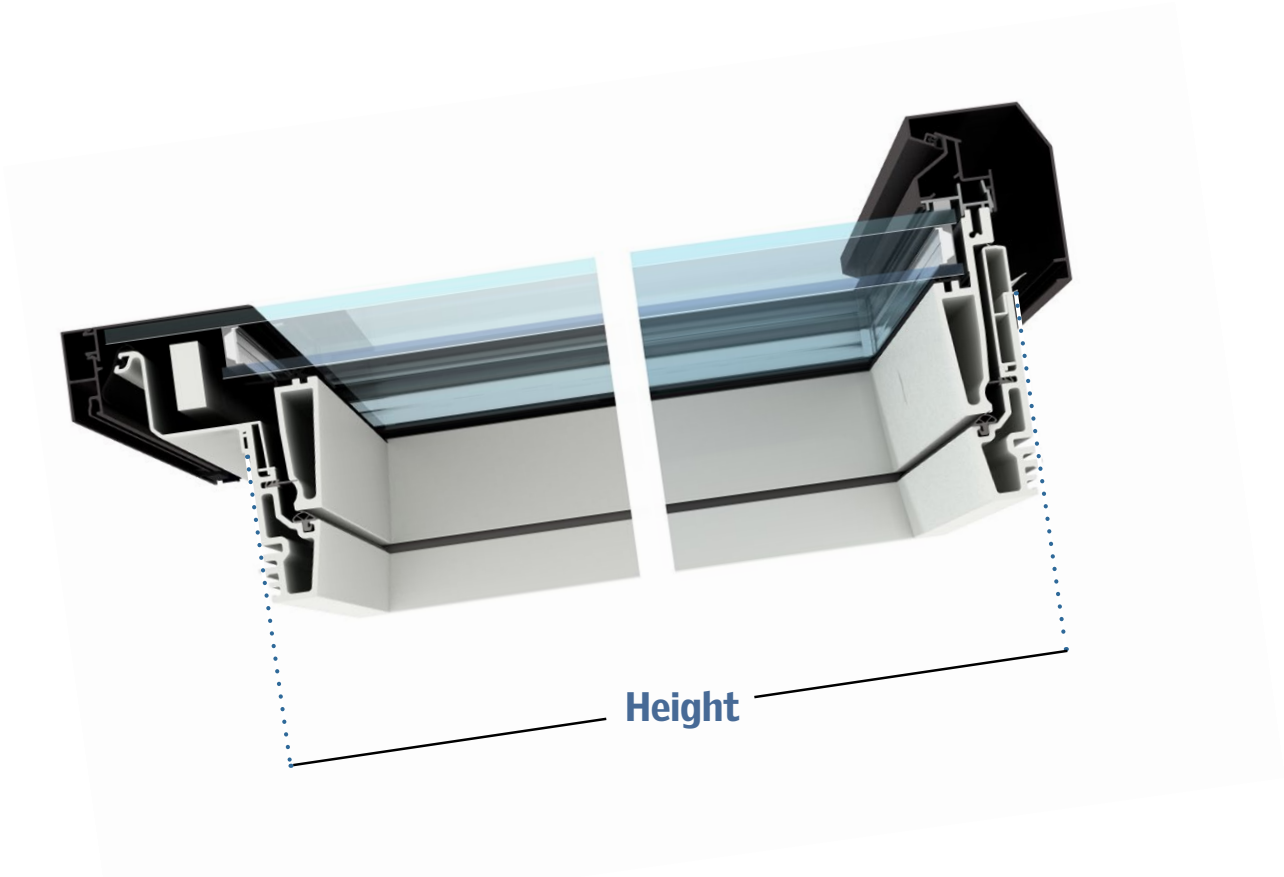
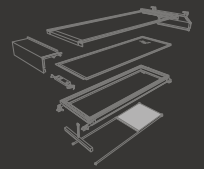



# Solutions

---

VELUX Modular Skylights can be combined in a number of configurations to create perfect solutions for a wide variety of building types, from narrow corridors and internal courts to studios and

large circulation spaces. Each solution is delivered with a specially designed, prefabricated flashing ensuring a perfect system.

## Mono pitched solutions

Longlight 5-30°

**Page: 54**

---

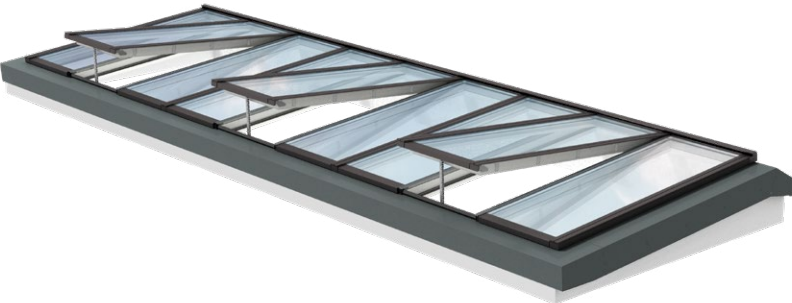

Wall-mounted Longlight 5-45°

**Page: 56**

---



Northlight 25-90°

**Page: 58**

---



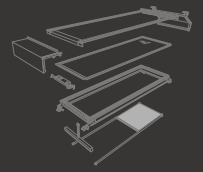

Dual pitched solutions

Ridgelight 25-40°

Page: 60

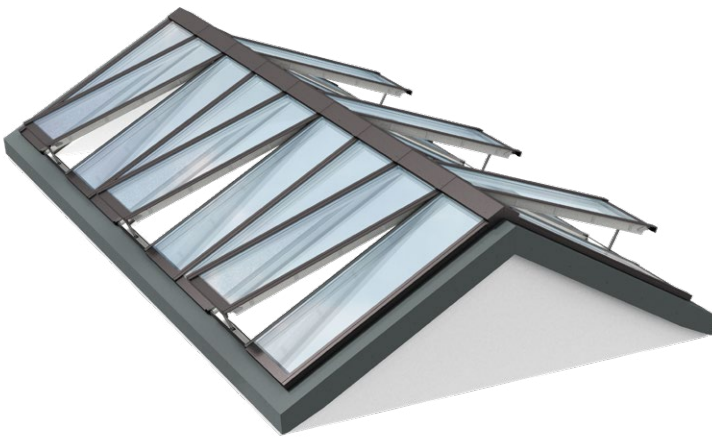

Ridgelight at 5° with Beams

Page: 62

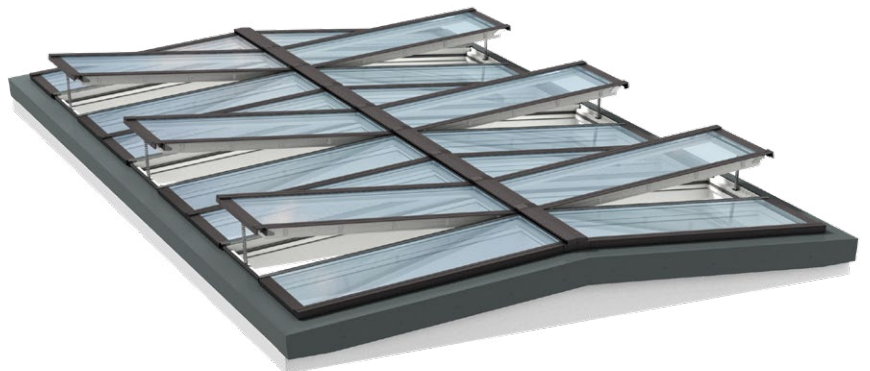





## Step solutions

Step Longlight 5-25°

Page: 66

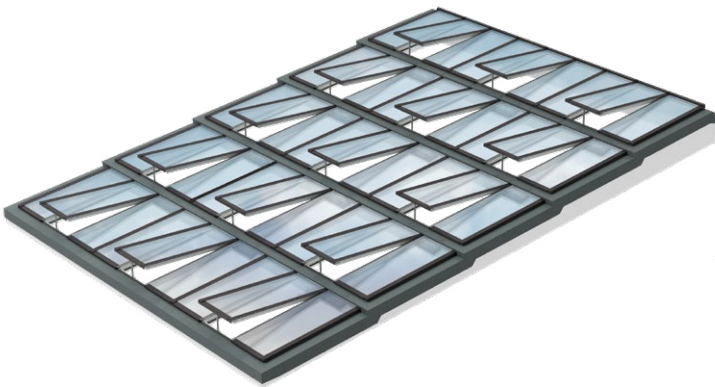

Step Wall-mounted Longlight 5-25°

Page: 68

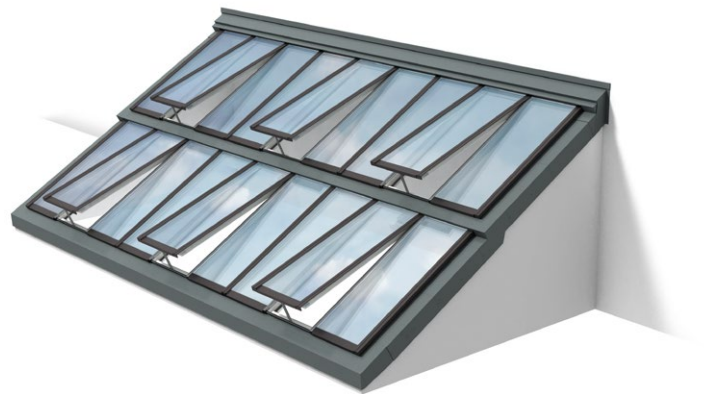

Step Ridgelight 25°

Page: 70

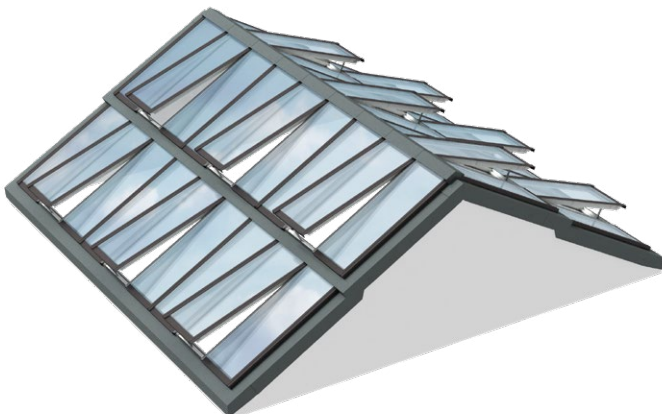

Step Ridgelight 5-25° on Girder

Page: 72

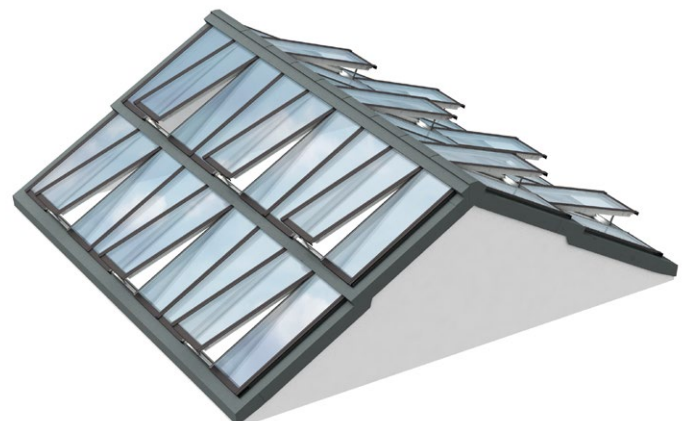

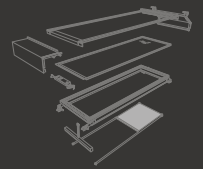

Atrium solutions

Atrium Longlight 5-30°

Page: 74



Atrium Ridgelight 25-40°

Page: 76



Atrium Ridgelight at 5° with Beams

Page: 76

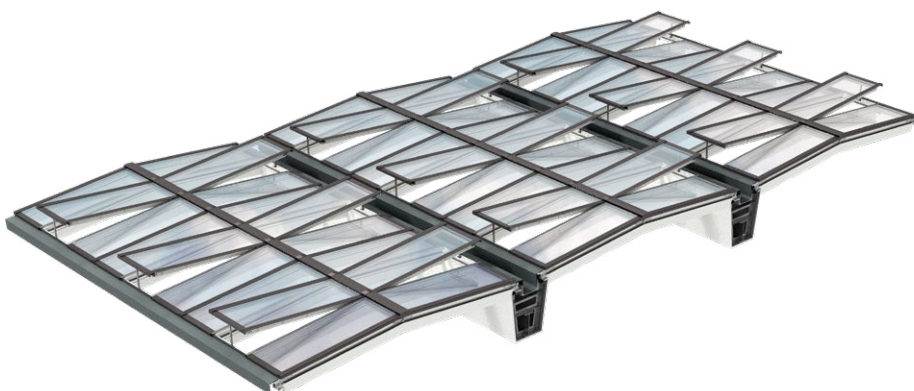

# Module – main components

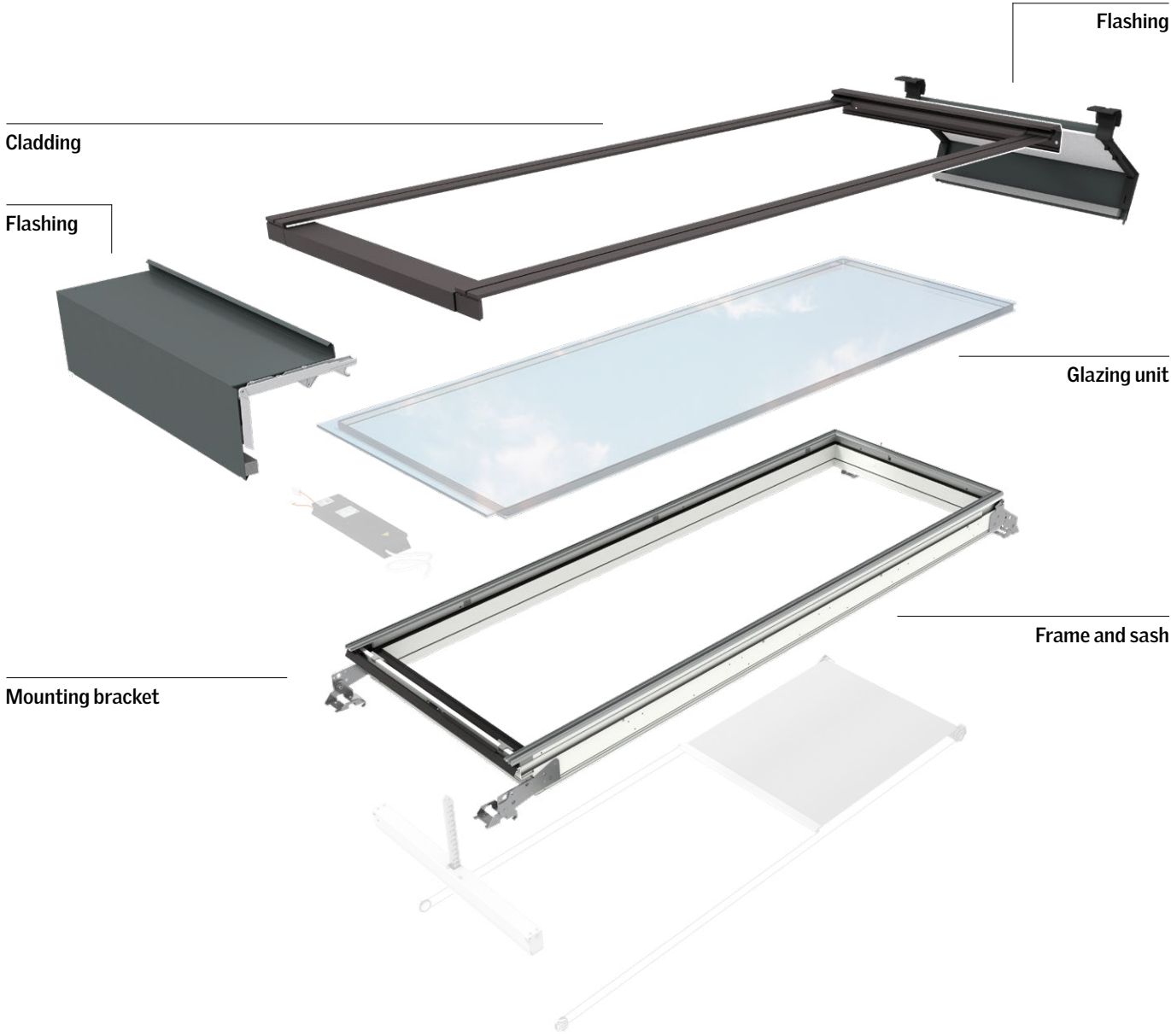



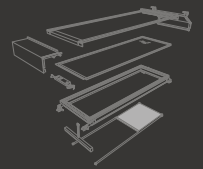

## Module – electrical components

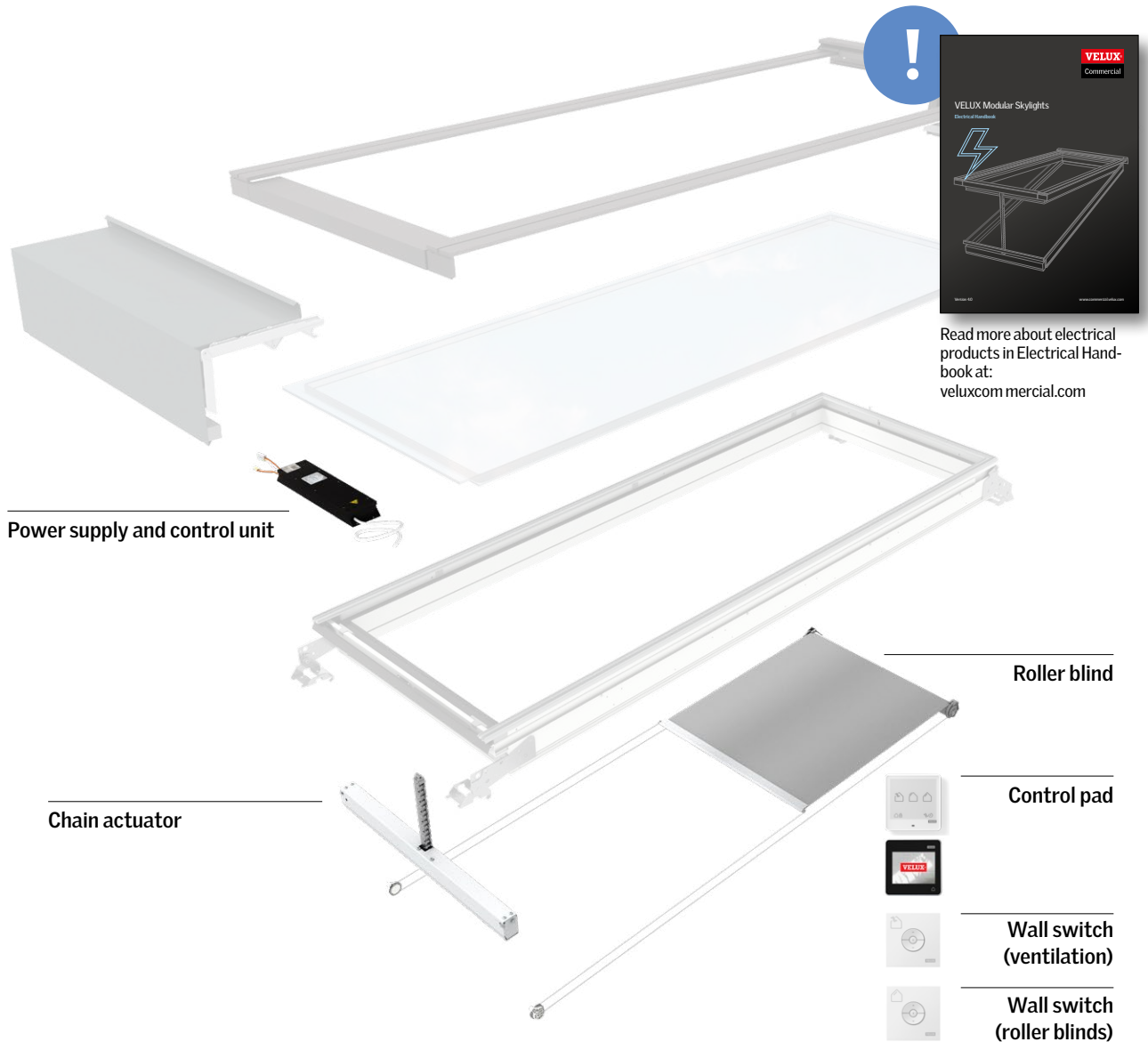

Power supply and control unit	Rain sensor	Rain and wind sensor set	Control pad	Wall switch	Switch interface (external wall switch)	Interface (external controls)
				 For ventilation  For roller blinds		
<b>KLC 410</b>	<b>KLA 200</b>	<b>KLA S105</b>	<b>KLR 200/ KLR 300</b>	<b>KLI 311/KLI 312</b>	<b>KLF 050</b>	<b>KLF 200</b>

## Frame & sash

---

The main structural profiles of VELUX Modular Skylights consist of pultruded composite, containing approximately 80% continuous fibreglass threads and 20% two-component polyurethane resin.

The composite guarantees a high heat insulating performance (page 20, graph 1) and thermal stability (page 20, graph 2), as well as, excellent profile stiffness (page 21, graph 3) and strength (page 21, graph 4). Combined, the characteristics of the VELUX composite give the slim profiles self-supporting strength and an ability to

support installations of considerable size. In addition, the material is maintenance-free, non-corrosive and electrically non-conductive.

Combined with low-energy glazing units, VELUX Modular Skylights have one of the lowest overall U-values for frame and glazing assemblies on the skylight market. The inner surface is treated with white paint as standard. However, other colours are available, see page 102.



Frame and sash assembled

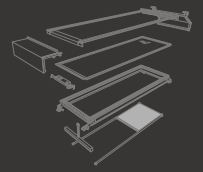

## Frame & sash

---

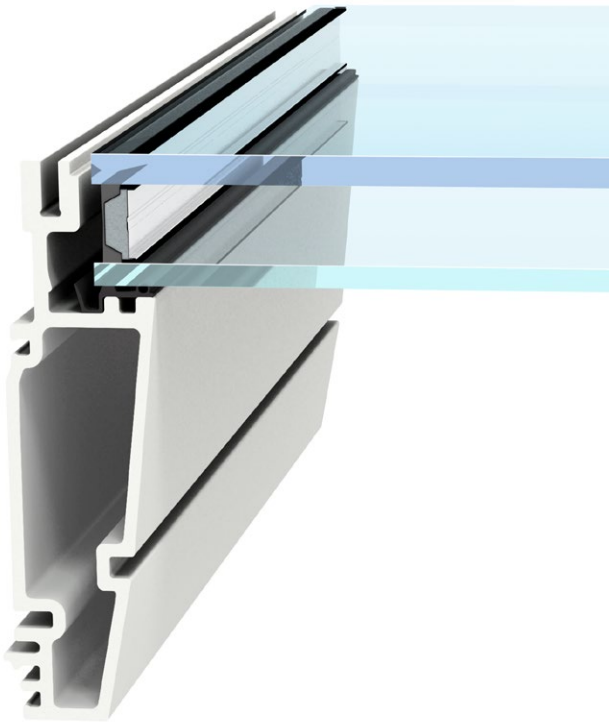

**HFC**

Frame for fixed skylight module

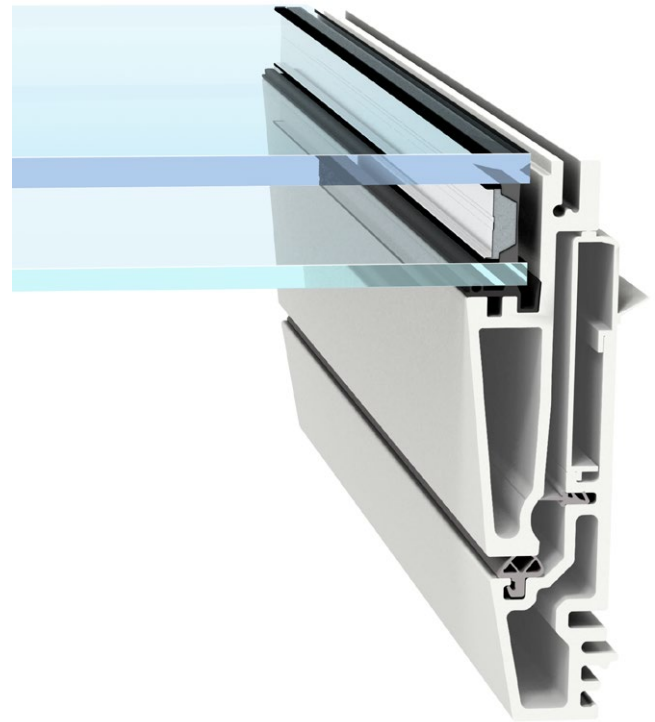

**HVC**

Frame and sash for venting skylight module



## Frame & sash

### 1 Thermal conductivity (W/mK)

- A low score means high insulating performance

Profiles used for VELUX Modular Skylights consist of pultruded fibreglass and polyurethane composite, which result in a high insulating performance.

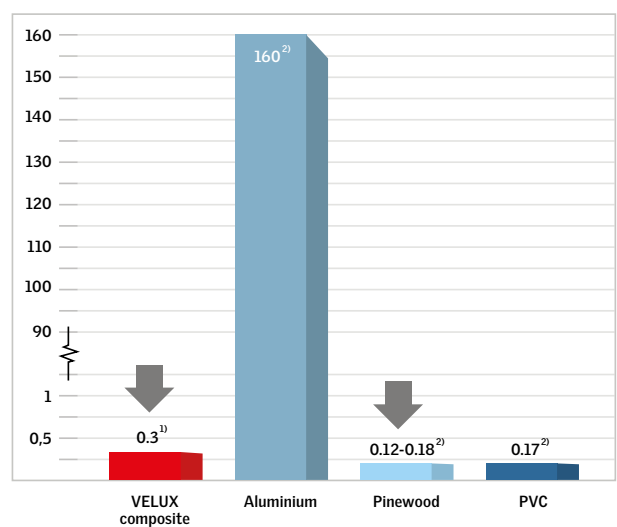

### 2 Linear expansion coefficient (10<sup>-6</sup> m/mK)

- A low score means high thermal stability

Whereas traditional skylight materials are bound to fluctuations in form due to thermal changes, the composite of VELUX Modular Skylights will maintain its dimensional properties, ensuring tightness of joints and prolonging the expected lifetime of the application.

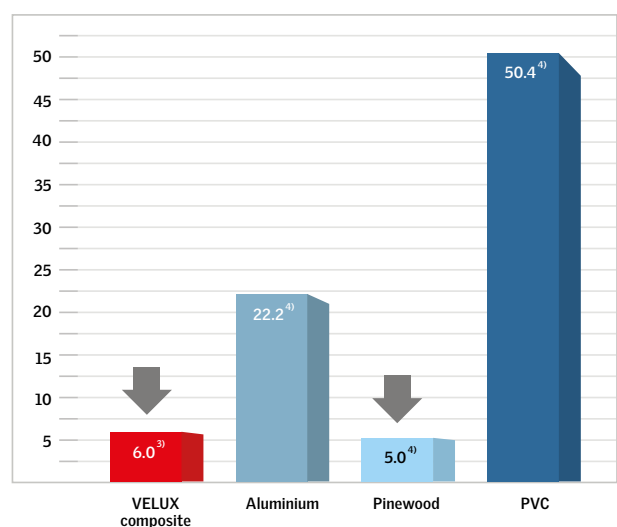

Source: <sup>1)</sup> Accredited external tests <sup>2)</sup> According to EN ISO 10077-2 <sup>3)</sup> Value identical to fibreglass <sup>4)</sup> www.engineeringtoolbox.com <sup>5)</sup> Internal VELUX test

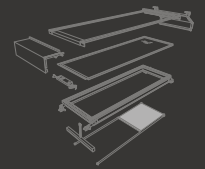

## Frame & sash

### 3 Flexural modulus (E-Modulus) (GPa)

- A high score means low deflection

The high rigidity of the pultruded composite material results in a very stiff frame and sash, ensuring reliable performance with very little deflection of the profiles and better aesthetics of the skylight.

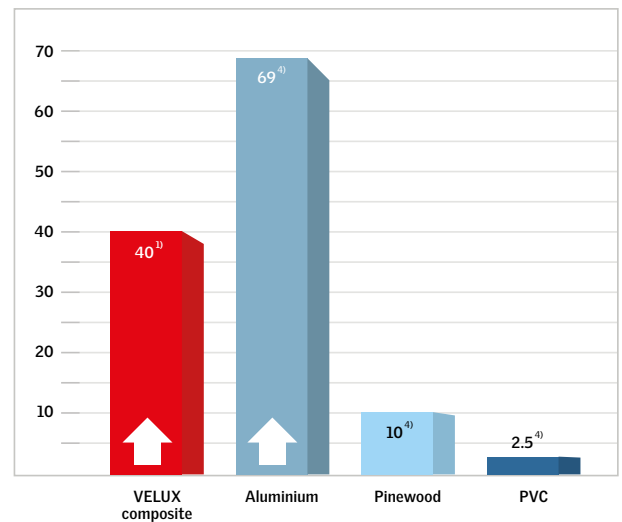

### 4 Flexural strength (N/mm<sup>2</sup>)

- A high score means high strength

The very high strength of the pultruded composite material allows for design and production of longer and slimmer frame and sash profiles than traditional skylight materials allow. This enables design of large skylights with slim profiles resulting in better aesthetic performance.

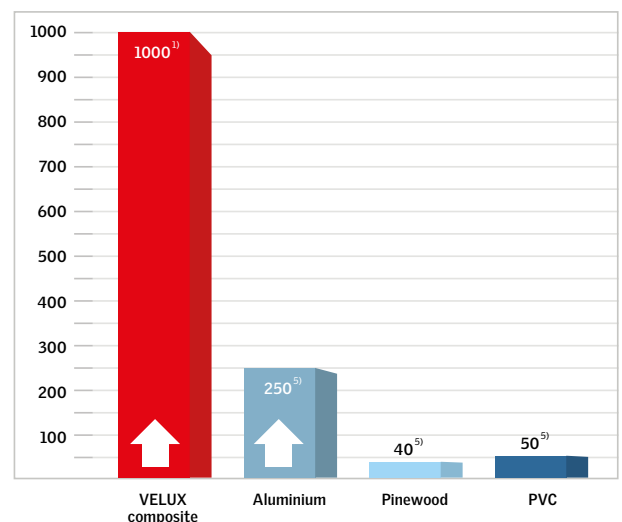

Source: <sup>1)</sup> Accredited external tests <sup>2)</sup> According to EN ISO 10077-2 <sup>3)</sup> Value identical to fibreglass <sup>4)</sup> www.engineeringtoolbox.com <sup>5)</sup> Internal VELUX test

## Cladding

---

### Cladding

Each module has a specific set of claddings. Cladding components are attached on four sides of the skylight, ensuring a watertight connection between sash and frame for both fixed and venting

modules. The cladding is made of extruded aluminium with a scratch resistant, granite grey powder coating for added weather protection and aesthetics. Other colours are available, see page 103.



## Flashing

---

### Flashing

VELUX Modular Skylights come with factory-finished flashings. The prefabrication of flashings ensures a high quality solution providing a watertight connection between roof, sub-construction and module, with a safe and fast installation process.

The flashing has a top, side and bottom section made from aluminium with a grey paint finish.

Other colours are available, see page 103.

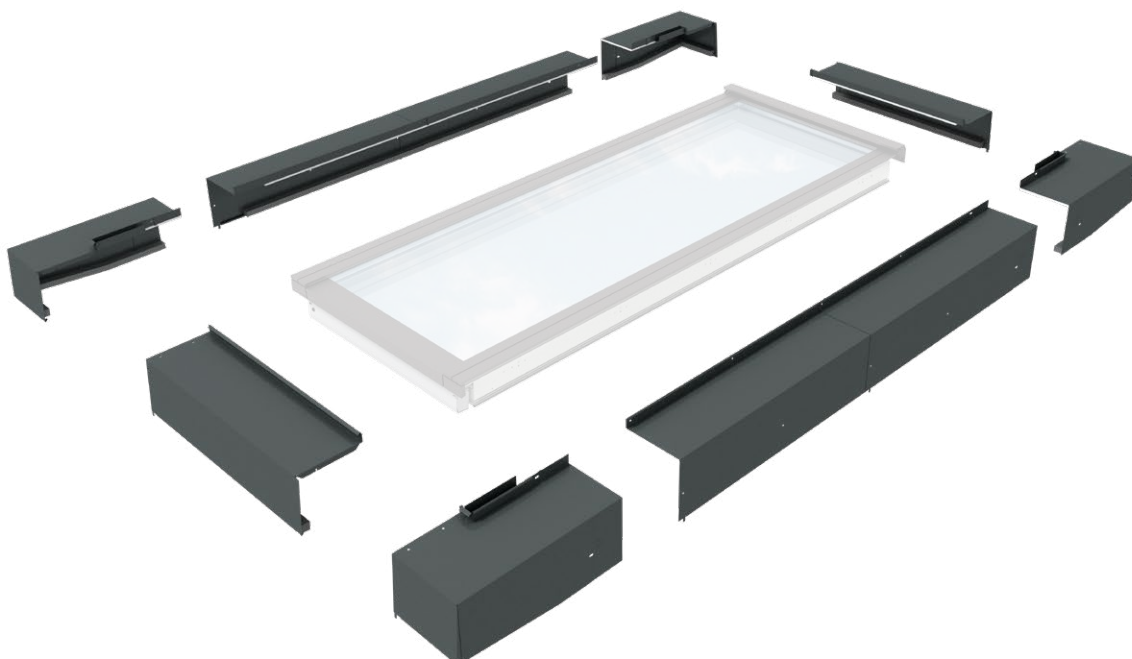



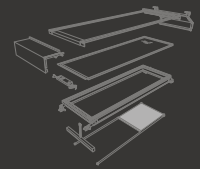

## Flashing

Standard flashing		Cross-section of the bottom flashing
<p><b>Standard flashing</b></p> <p>Standard top, bottom and side flashing suitable for a 210 mm sub-construction (measured from inside edge of the steel). See page 32.</p>		<p>210 mm</p>
Semi-standard flashing		Cross-section of the bottom flashing
<p><b>Narrow flashing</b></p> <p>Narrow top, bottom and side flashing that is suitable for a 150 mm wide sub-construction.</p> <p>Available at additional cost.</p> <p>Can be used for instance, if the extra slim sub-construction is required.</p>		<p>150 mm</p>
<p><b>Wide flashing</b></p> <p>Wide top, bottom and side flashing that is suitable for a 350 mm wide sub-construction.</p> <p>Available at additional cost.</p> <p>Can be used for instance, if the sub-construction is made of concrete and space for insulation is needed.</p>		<p>350 mm</p>

## Glazing unit

VELUX Modular Skylights come with a low-energy double-glazing unit. Alternatively, the modules can be supplied with improved solar protection or an Argon or a Krypton filled triple-glazing unit for extra-low U-value. All glazing units include a toughened outer glass layer and a 3+3 or 5+5 mm inner safety glass layer with 2 x 0.38 mm interlayer PVB foil. For technical values on glazing units, please refer to the chapter about Product Data.

The triple-glazed units have a heat strengthened middle glass layer. For triple-glazed variants with a 5+5 mm inner pane, heat strengthened glass is used.

The cavity between the panes of the glazing units is filled with Argon or Krypton gas as a default.

All glazing units have a warm edge spacer and are produced with warm edge technology to minimise the risk of condensation and to give the glazing units the most durable insulation capabilities.



Please note that panes for intentional walkability require a dedicated walk-on product fulfilling load bearing requirements per Eurocode, national annexes to Eurocodes, further national safety guidelines and anti-slippery protection requirements.

VELUX Group does not proactively encourage walking / stepping on panes of slope products intentionally. Per request, the glazing construction and occasionally when available national certificates can be disclosed, however the decision whether customer accepts the glazing and allow walkability in use lies solely with the customer.

# Glazing unit

## Example of double-glazed unit (LowE)

### Variant 10L

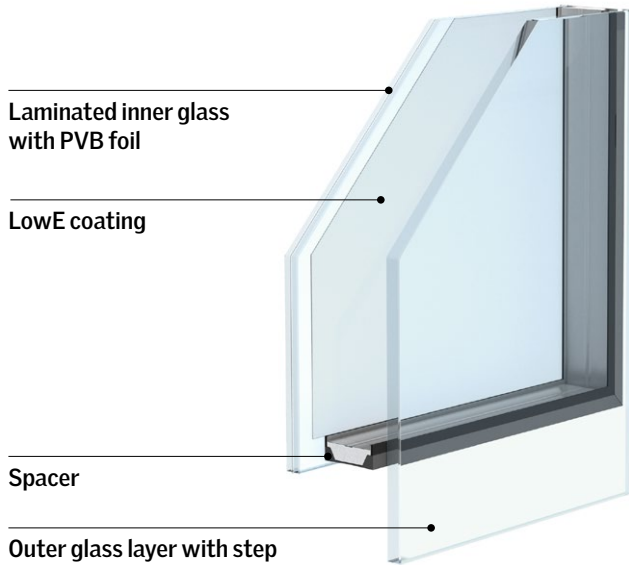

## Example of triple-glazed unit (LowE)

### Variant 16L

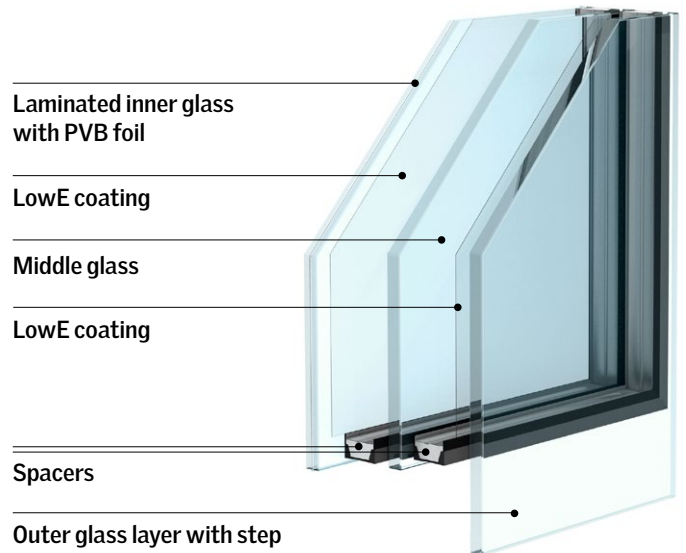

**Note:** Visual quality of glazing units. Interference effects and/or effects specific to multiple glazing and/or anisotropy may occur in the visible glass surface due to the physics of the material and its production technologies.

## Differentiating parameters of the coating variants

Coating options		Coating	Solar gain	Solar protection	Light transmittance	Colour rendering index
<b>Low emissivity</b>	When the highest light transmittance is needed and you would like to let in the heat from the sun during heating season.	<b>LowE</b>	☆☆☆	☆	☆☆☆	☆☆☆
<b>Sun protection</b>	When sun protection is required to keep out the heat from the sun for increased comfort during summer periods.	<b>Sun1</b>	☆☆	☆☆	☆☆	☆☆
<b>Enhanced sun protection</b>	When extra sun protection is required for increased comfort during summer periods and a reduced light transmittance can be accepted.	<b>Sun2</b>	☆	☆☆☆	☆	☆

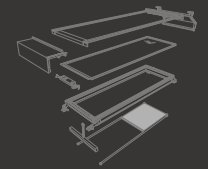

## Glazing unit

### Colour renderings of double-glazed units

Additional glazing characteristics and glazing variants are shown on pages 98-100.  
All mentioned values are in accordance with EN 410.



#### Glazing with low emissivity coating (LowE)

##### Variant 10L

Light transmittance:  $\tau_v$ -value = 80%  
Solar factor: g-value = 61%  
Colour rendering index:  $R_a$  = 97

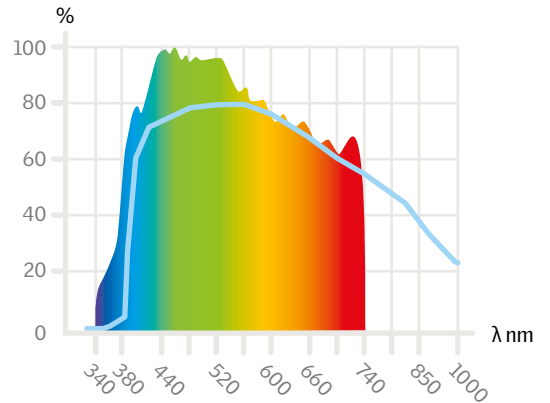

#### Glazing with light sun protection coating (Sun1)

##### Variant 11L

Light transmittance:  $\tau_v$ -value = 52%  
Solar factor: g-value = 28%  
Colour rendering index:  $R_a$  = 84

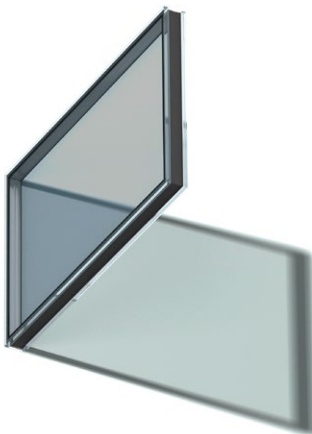
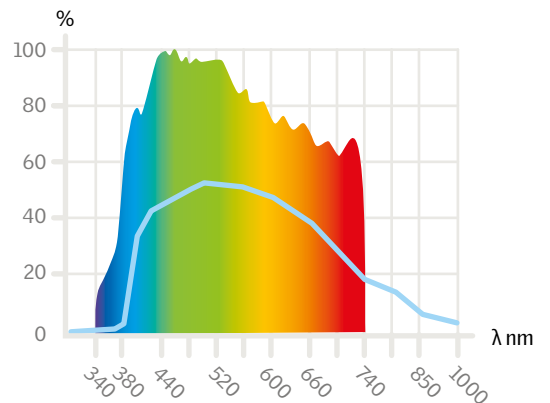

#### Glazing with enhanced sun protection coating (Sun2)

##### Variant 12T

Light transmittance:  $\tau_v$ -value = 18%  
Solar factor: g-value = 17%  
Colour rendering index:  $R_a$  = 92

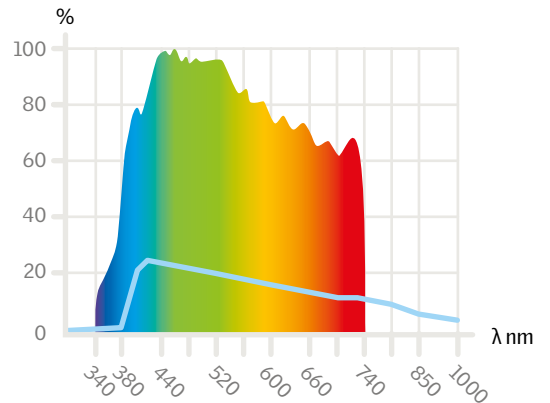

Spectral values (wave length in nm)

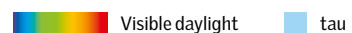



# Glazing unit with low emissivity coating and roller blind RMM

## Colour renderings of double-glazed units

Additional glazing characteristics and glazing variants with roller blind are shown on pages 108 and 109. All mentioned values are in accordance with EN 410.



### Glazing with low emissivity coating (LowE) and Roller Blind RMM 8806, White

#### Variant 10L

Light transmittance:  $\tau_v$ -value = 31%  
 Solar factor: g-value = 36%  
 Colour rendering index:  $R_a$  = -

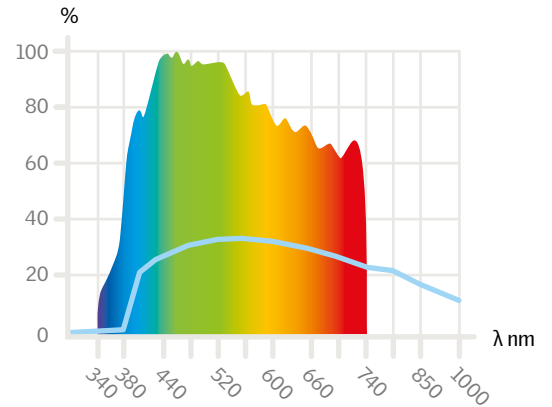

### Glazing with low emissivity coating (LowE) and Roller Blind RMM 8805, Grey

#### Variant 10L

Light transmittance:  $\tau_v$ -value = 8%  
 Solar factor: g-value = 43%  
 Colour rendering index:  $R_a$  = -

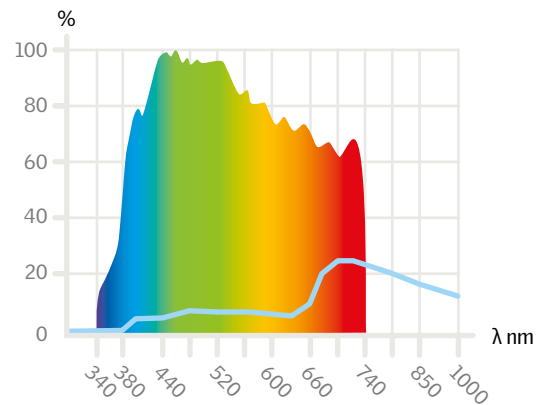

### Glazing with low emissivity coating (LowE) and Roller Blind RMM 8807, Black

#### Variant 10L

Light transmittance:  $\tau_v$ -value = 0%  
 Solar factor: g-value = 37%  
 Colour rendering index:  $R_a$  = -

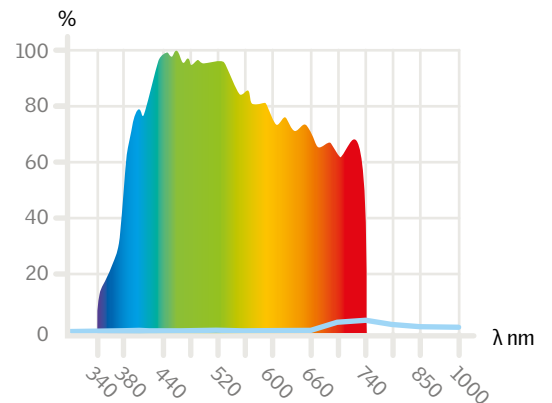

Spectral values (wave length in nm)  
 Visible daylight tau

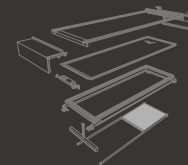

## Glazing unit with fritted or opal surface

### Colour renderings of double-glazed units

Additional glazing characteristics and glazing variants are shown on pages 98-100.  
All mentioned values are in accordance with EN 410.



#### Glazing with low emissivity coating (LowE)

##### Variant 10L

Light transmittance:  $\tau_v$ -value = 80%  
Solar factor: g-value = 61%  
Colour rendering index:  $R_a$  = 97

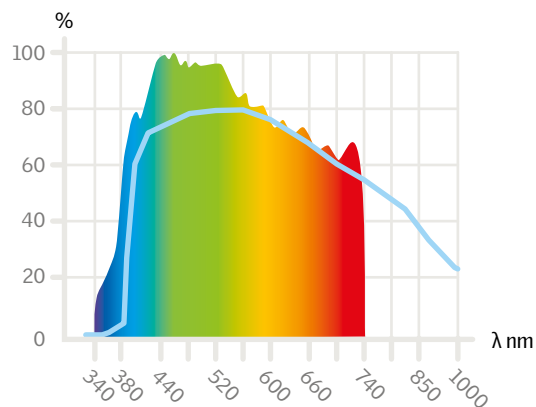

#### Glazing with low emissivity coating (LowE) and opal surface\*

##### Variant 10L + opal

Light transmittance:  $\tau_v$ -value = 58%  
Solar factor: g-value = 58%  
Colour rendering index:  $R_a$  = -

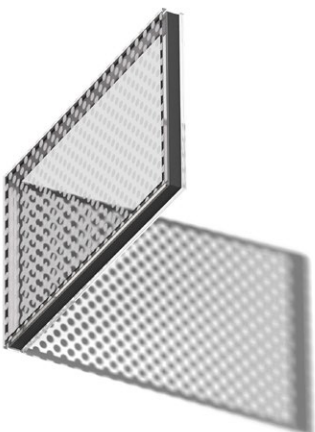
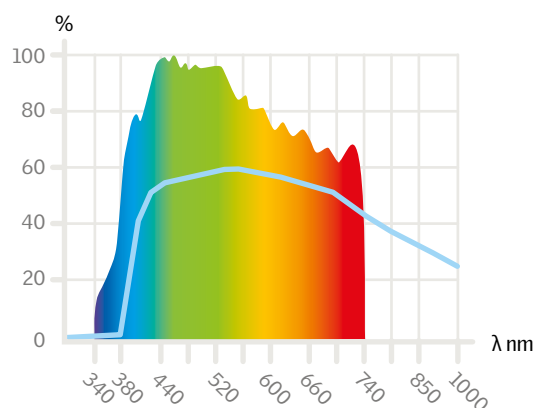

#### Glazing with low emissivity coating (LowE) and fritted surface\*

##### Variant 10L + fritted

Light transmittance:  $\tau_v$ -value = 80%  
Solar factor: g-value = 61%  
Colour rendering index:  $R_a$  = -

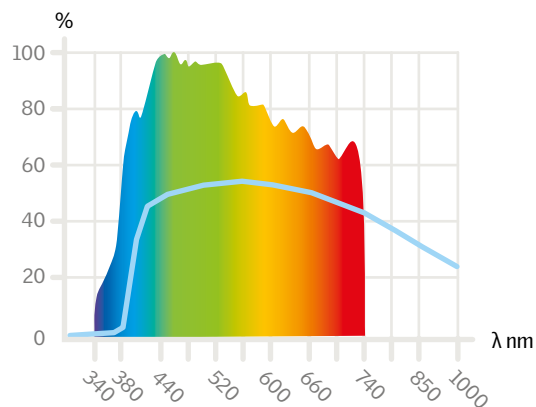

\* Glazing with opal or fritted surface are semi-standard variants. The above values (with opal or fritted surface) are based on examples and depend on covering degree and pattern.

## Brackets & hinges

---

### Material and surface treatment

Metal components in VELUX Modular Skylights are made of galvanized steel.

The majority of the steel components are electroplated according to European norm EN ISO 2081 table A1 – C: iridescent. Components fulfill corrosion resistance grade 4 in accordance with EN ISO 1670.

Based on these properties, VELUX Modular Skylights can be used where external weather conditions and indoor climate conditions are within the normal spectre of corrosiveness.

Note: VELUX Modular Skylights standard solutions must NOT be used in indoor environments where the risk of condensation on metal components can lead to extreme corrosive attacks. These environments include facilities that use highly corrosive substances, e.g. salt and/or chloride. Evaporation can lead to corrosive attacks on components, weaken the functionality and in the end compromise the structural integrity of the installation. For use of VELUX Modular Skylights in buildings with swimming pools, specific swimming pool products are available, see page 35.

### Brackets

VELUX Modular Skylights are supplied with mounting brackets and clamps and are ready to be installed on any preferred sub-construction made of steel, concrete or wood finished with a steel profile at the top. Mounting brackets are fixed during installation with a clamping system holding the skylight in place.

Using a steel profile on top of the sub-construction is an advantage, as the clamps at any time during installation can be released to allow minor positional adjustment of the modules.

If the customer chooses not to use the mounting clamps, but to screw the mounting brackets directly into the wooden batten, please note that the screws are not included in the VELUX delivery, and therefore delivery and correct dimensioning must be ensured by the customer.

### Hinges

The pre-fitted hinges of the venting modules are tested under the most severe conditions, by continuously opening and closing the largest and heaviest modules.



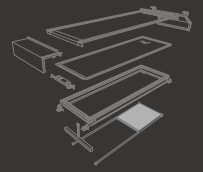

## Examples of brackets & hinges



Top bracket for Longlight 5-30°

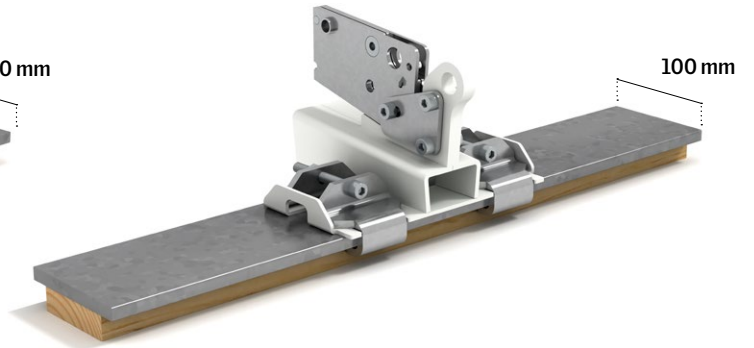

Bottom bracket for Ridgelight at 5° with Beams.  
Parallel beam with curved profile.

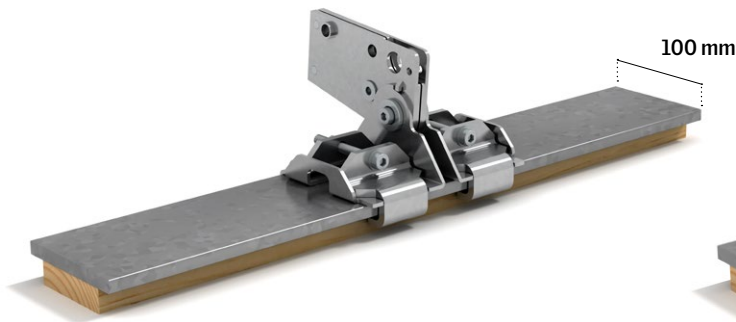

Bottom bracket for Longlight 5-30° and Ridgelight 25-40°

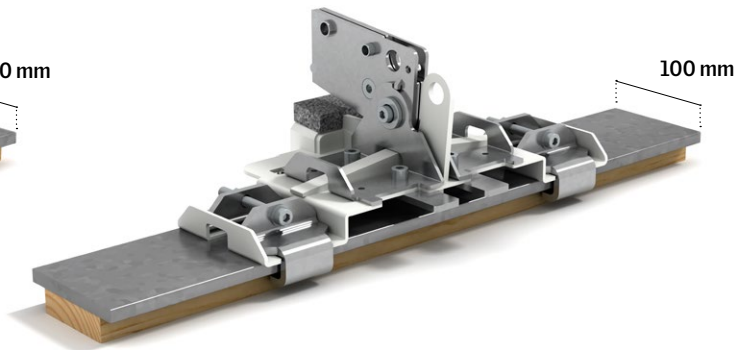

Bottom bracket for Ridgelight at 5° with Beams.  
Horizontal beam with rectangular profile.



Top bracket for Northlight 25-90°



Top bracket for Wall-mounted Longlight 5-45°



Top bracket for Ridgelight at 5° with Beams



Top bracket for Ridgelight 25-40°



Clamp for fixing mounting  
bracket on steel profile



## Module – assembled

---

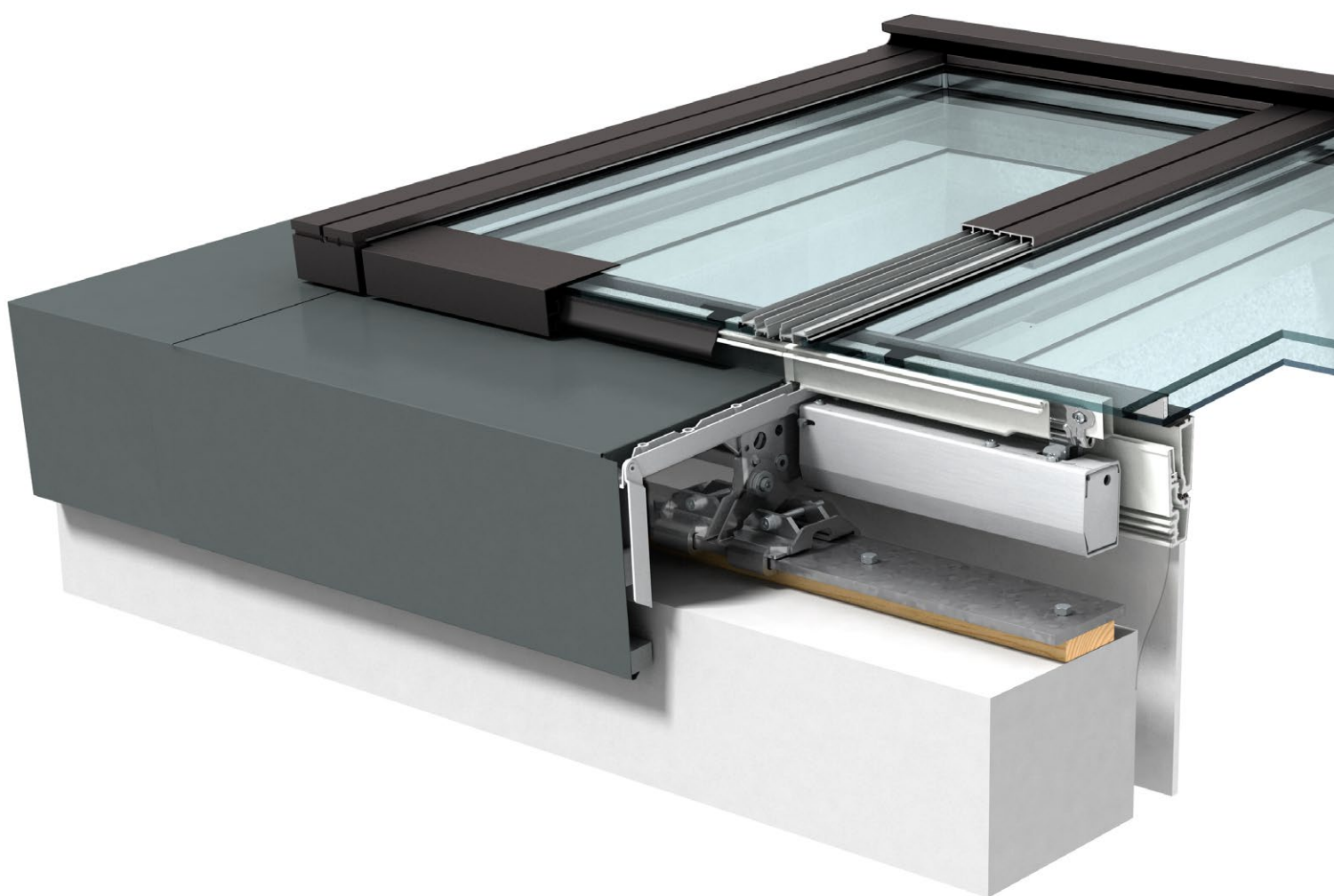

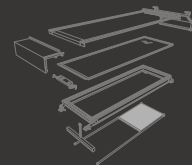

## Sub-construction

### Easy installation process

VELUX Modular Skylights require an accurate, fixed and dimensioned sub-construction. The strength of the sub-construction must also be calculated for the individual project, based on the building design and application size. It is the responsibility of the customer to have a static calculation of the sub-construction done by a static engineer.

In this way, the sub-construction is not a part of the prefabricated modular skylight system.

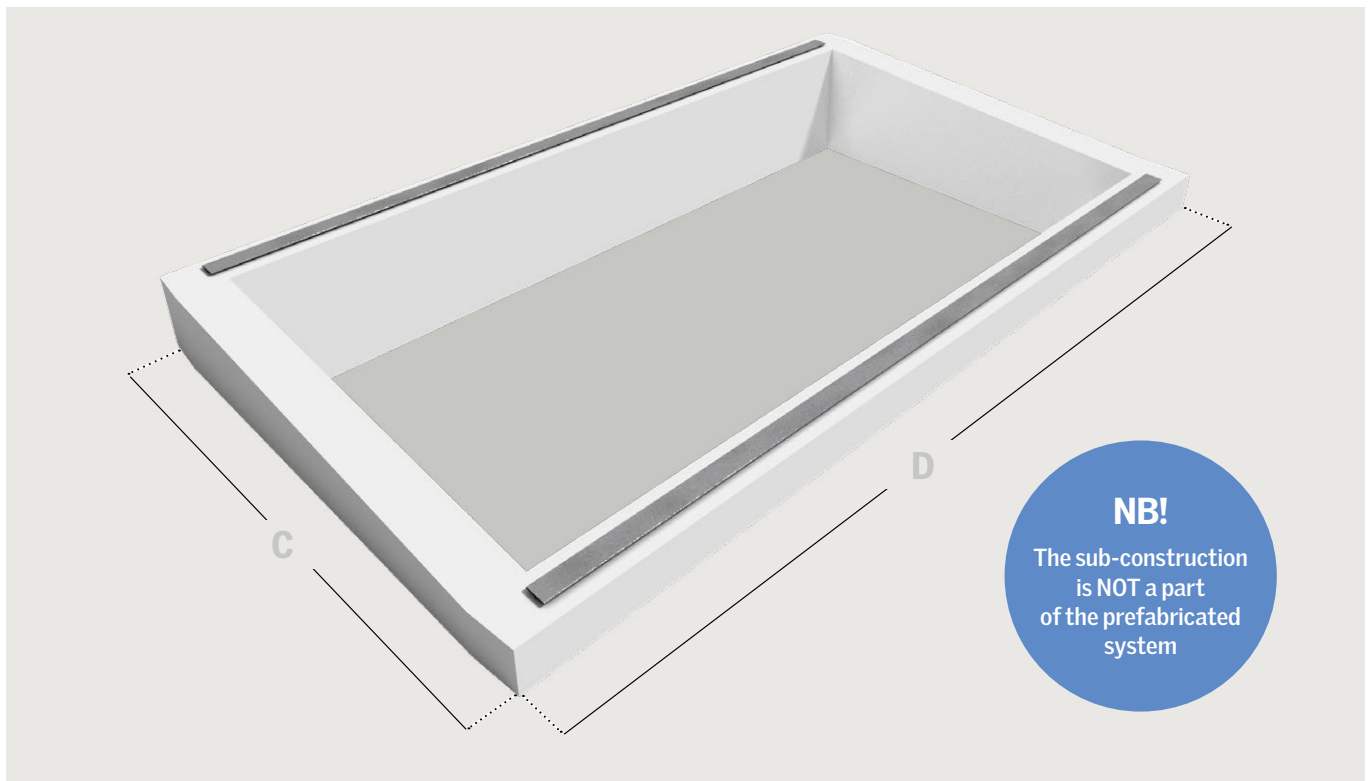

**Wood sub-construction finished with a steel profile at the top**



Wood is the most flexible choice for creating a light and economical sub-construction with maximum energy performance. However, it is not recommended for larger solutions and Ridgelight installations.

**Steel sub-construction finished with a steel profile at the top**

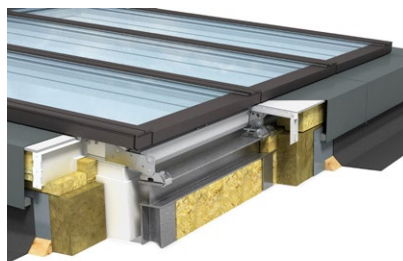

Steel offers flexibility in combination with great strength. Steel also allows a maximum amount of insulation to be used in the installation.

**Concrete sub-construction finished with a steel profile at the top**

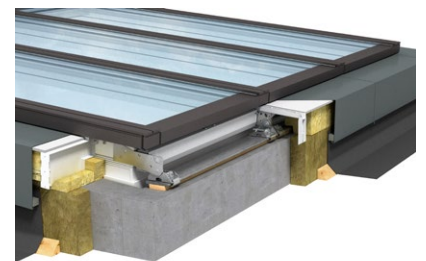

Concrete provides a strong, but heavy sub-construction and is mostly suited for concrete buildings. Concrete sub-constructions are usually cast on site.

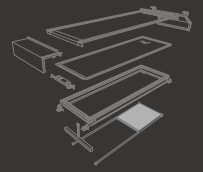

## The steel profile

A steel profile is the most important link when mounting the modules to the sub-construction. Please observe that the steel profile should cover the full opening length to allow minor

positional adjustment of the modules during installation. Please also observe that the top and bottom sub-construction and therefore also the steel profile must be horizontal.



Steel profile on wood



Steel profile on steel

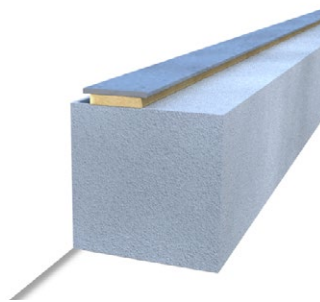

Steel profile on concrete

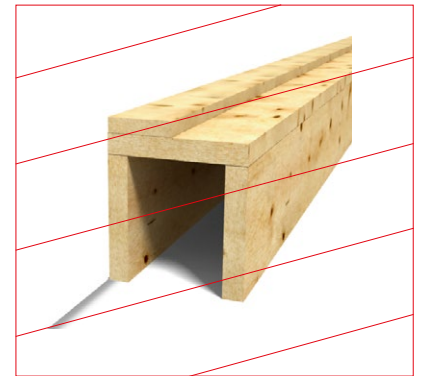

Wood profile on wood is not recommended by VELUX Commercial.

## Download material and recommendations on sub-construction



See our large selections of material on Longlight, Wall-mounted Longlight, Northlight, Ridgelight, Ridgelight at 5° with Beams, Step, Longlight, Step Ridgelight, Step Ridgelight on Girder, Atrium Longlight, Atrium Ridgelight and Atrium Ridgelight at 5° with Beams

Read all about sub-constructions in the guides at: [veluxcommercial.com](http://veluxcommercial.com)



## Vapour barrier connection strip

To ensure a high quality installation of VELUX Modular Skylights and to prevent condensation occurring within the sub-construction, it is highly recommended to install BCX vapour barrier connection strip.

The factory-finished BCX creates the perfect connection between the VELUX Modular Skylights and the vapour barrier of the building. BCX is CE-marked in accordance with EN 13984.

The vapour barrier connection strip BCX is made of a diffusion-tight polyethylene foil completed with a pre-fitted rubber gasket along one edge. With a perfect fit into the skylight frame rebate, installation is an easy job that guarantees a vapour-tight solution.

Vapour Barrier Connection Strip  
(Factory-finished)

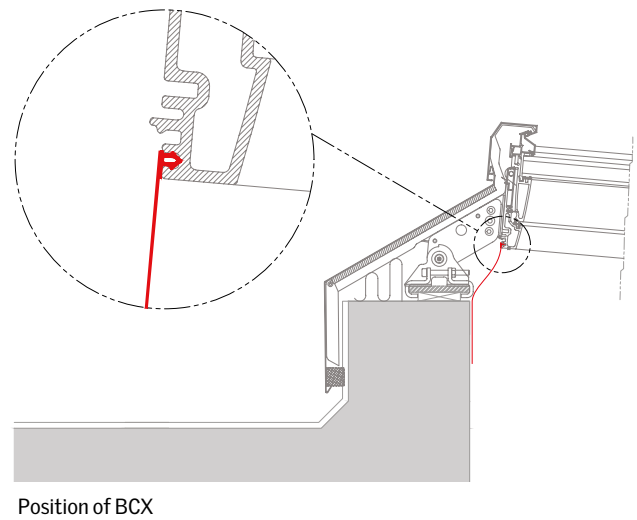

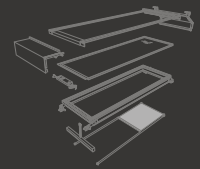

## Products for swimming pool environments

When using VELUX Modular Skylights in environments like swimming pools with high levels of humidity, salt or chloride, it is crucial to ensure a vapour tight installation to prevent condensation of highly corrosive substances like salt and/or chloride that can lead to corrosive attacks on metal components.

VELUX specially designed vapour barrier connection strip, vapour barrier adhesive and inner ridge cover must be used in environments with swimming pools. Please observe any national requirements in swimming pool areas.

### Vapour barrier connection strip for swimming pools

The factory-finished vapour barrier connection strip BSX developed especially for use in swimming pool environments creates the perfect connection between the VELUX Modular Skylights and the vapour barrier of the building. BSX is CE-marked in accordance with EN 13984.

BSX is made of a multilayer foil including aluminium with a very high water vapour resistance completed with a pre-fitted rubber gasket along one edge. Vapour barrier adhesive ZZZ 255 to be used together with vapour barrier connection strip.

### NOTE:

Guarantee provided by VELUX for swimming pool projects is valid only when these dedicated swimming pool products are used correctly. Triple glazing is advised to minimise the risk of condensation. Roller blinds and Ridgelight at 5° with Beams are not compatible for use in swimming pool environments. For use of Northlight solutions, it is important that the roof construction is sufficiently ventilated close to the modules. Fire resistant module HFS is not compatible for use in Ridgelight solutions above swimming pools.

### Inner ridge cover for swimming pools

For use of Ridgelight solutions above swimming pools, a specially designed inner ridge cover ZZZ 254 must be used. ZZZ 254 is made of 2 mm thick extruded white EPDM rubber. Please observe that due to material properties, there is a colour difference between ZZZ 254 and the white skylight frame. Vapour barrier adhesive ZZZ 255 to be used together with inner ridge cover.

Vapour barrier connection strip for swimming pools	Vapour barrier adhesive for swimming pools	Inner ridge cover for swimming pools
		
BSX	ZZZ 255	ZZZ 254

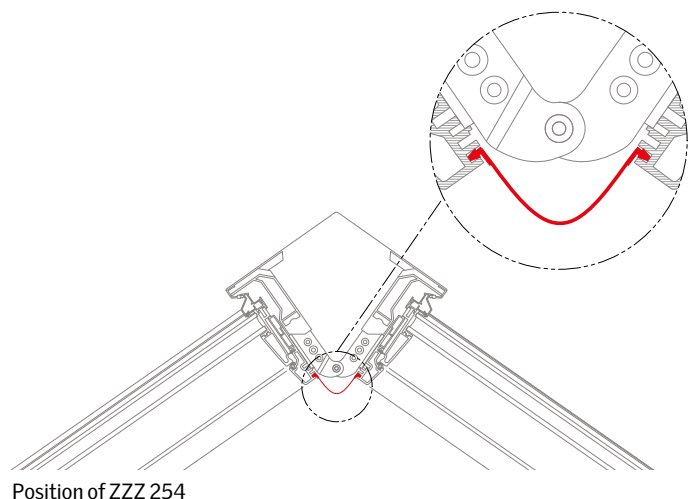
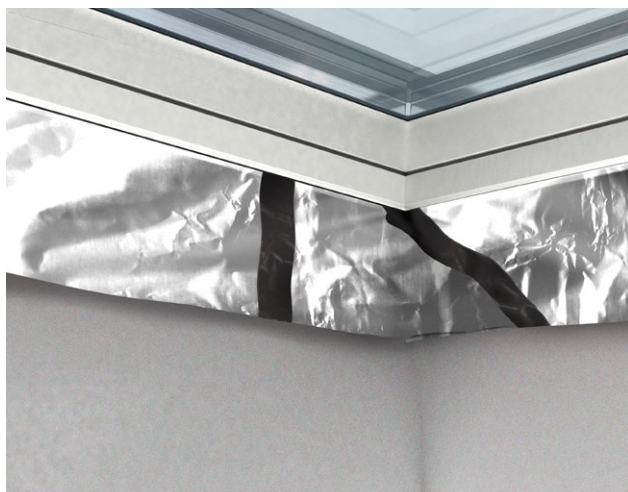

# Chain actuator

VELUX venting skylight modules are top-hung and have a hidden chain actuator integrated at the bottom profile.

For comfort ventilation there is one chain actuator variant which can be controlled with either VELUX io-homecontrol® technology and control pad KLR 200 or KLR 300 for user friendly control or your preferred ± 24 V DC open system. The chain actuator for smoke ventilation can only be controlled by a ± 24 V DC open system.

The chain stroke on the open system actuator can be reprogrammed even after installation to suit specific needs.

The chain actuator is accessible from the roof. Therefore, maintenance requires no access from the inside of the building.

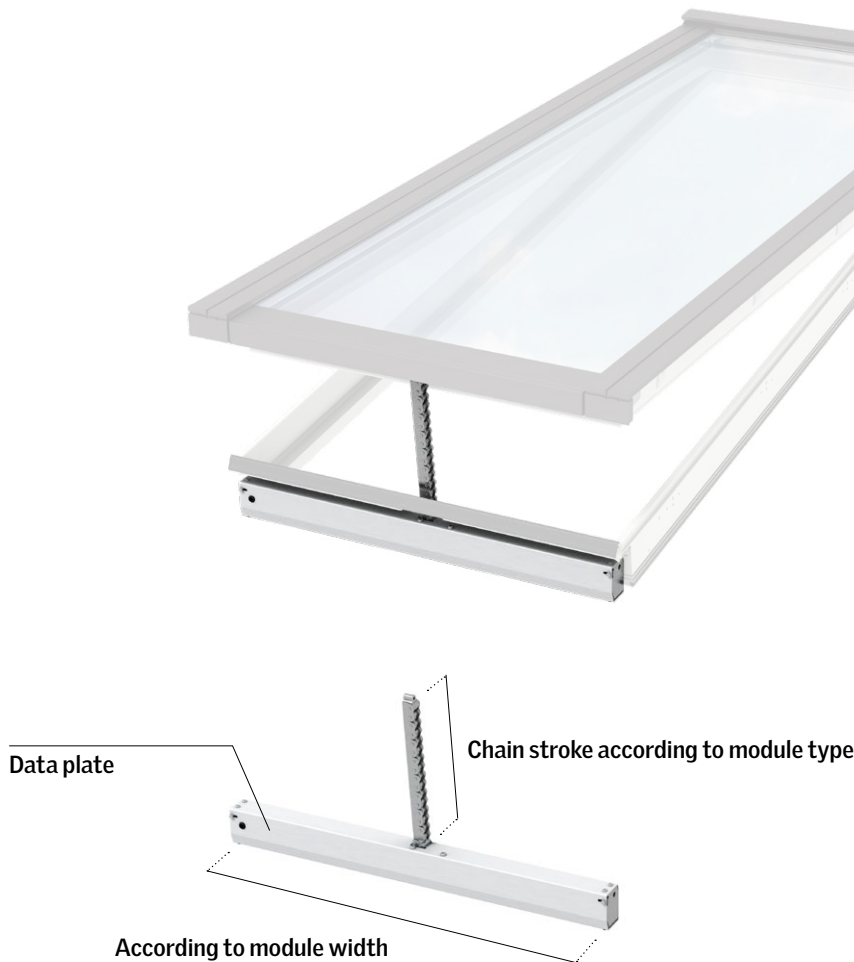

Comfort venting VELUX Modular Skylights meet the requirements of the harmonised standard EN 60335-2-103(2015) as to a max opening clearance of 200 mm (by means of physical limitation of the actuator) and as to the max closing speed of 15 mm/sec. Therefore, comfort venting skylights can be installed within reach, i.e. at installation heights below 2.5 m above floor level (inside) and ground level (outside). According to EN 60335-2-103 access levels are defined as e.g. stairs and terraces. Surfaces not normally used for standing on, such as windowsills, and movable equipment such as ladders, are not considered to be access level.

Please note that the venting skylights operate with high closing force, which can cause serious injury in case of entrapment. If VELUX roller blinds are installed in the skylight, please observe recommendations in the safety instructions provided with each VELUX roller blind RMM.

We recommend that you observe national regulations and consider if the planned specific use of the building requires additional safety measures that must be applied by the installer/user to prevent serious injury.

Smoke venting VELUX Modular Skylights and comfort venting VELUX Modular Skylights with a longer chain stroke than standard have a recommended minimum installation height of 2.5 m above floor level (inside) and ground level (outside). If they are installed below this level, safety measures must be applied by the installer/user to prevent serious injury. No instruction or measure can eliminate the inherent hazards resulting from installation heights below 2.5 m.

The VELUX Group will not accept responsibility for damages, injury or death resulting from such an installation. The installer/user is ultimately responsible for own omissions and actions. Measures could for instance be to install a motion sensor that is able to disconnect power from the control unit in case of any movement in the immediate vicinity of the VELUX Modular Skylights.

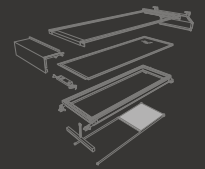

## Control system

### VELUX io-homecontrol®

Venting modular skylights and roller blinds RMM can be powered and controlled from the VELUX control unit KLC 410. Each KLC 410 can power and operate one venting skylight module and up to four roller blinds individually, in groups or simultaneously.

Skylights and blinds installed with the VELUX KLC 410 control unit can be operated with the VELUX wall switches KLI 311/312 or control pad KLR 200/300.

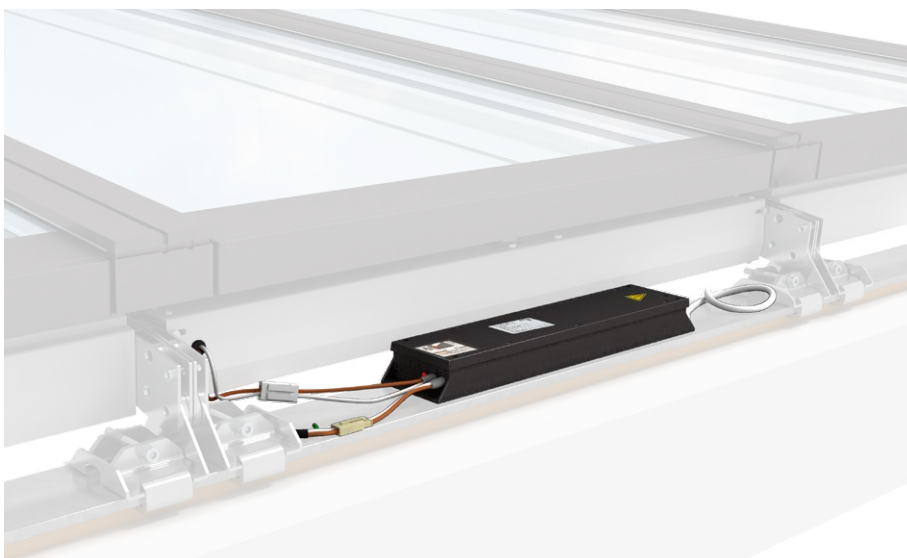
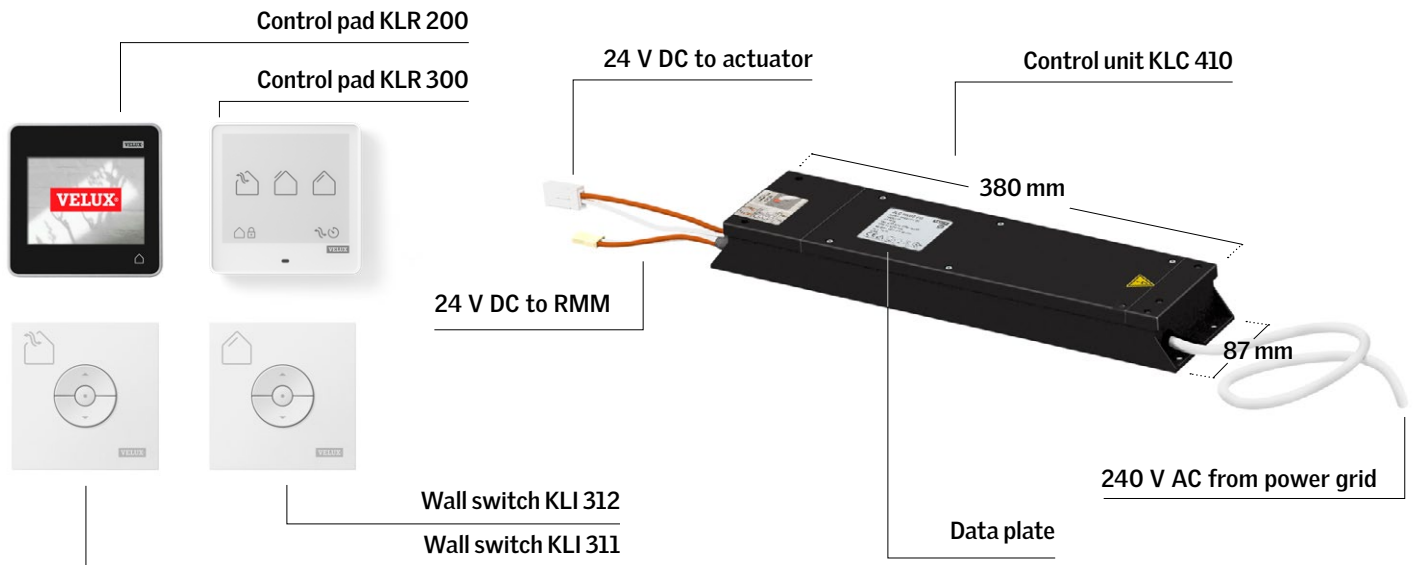

### Open system

Venting modular skylights and roller blinds controlled with the open system solution are connected to  $\pm 24$  V DC. In addition to  $\pm 24$  V DC, the open system skylights and roller blinds can be connected to and integrated in common building automation fieldbus systems, i.e. KNX, BACnet, LON and Modbus.

The connection to the skylight actuator is made through the integrated WindowMaster MotorLink™ technology that among other things enables exact position control and feedback.



## Roller blind

The internal roller blind RMM is designed for installation with VELUX Modular Skylights, and is available in all standard module sizes above 800 mm in height. The blind protects against heat and glare and helps to control the amount of light in the room.

The blind consists of four wheels, one in each corner of the skylight module and two steel wires, running along the module side frame. The two wires pull a lightweight polyester fabric available in three commonly used colours.

VELUX roller blinds are electrically operated and can be controlled using either VELUX io-homecontrol® or Open System ±24V (OS ±24V DC).

To support fast and safe installation of VELUX Modular Skylights, it is possible to order roller blinds pre-mounted from the factory, except on smoke venting modules and fire resistant modules.

VELUX Modular Skylights can be pre-fitted with cables for internal roller blinds, making the installation and connection to the module and to the power supply quick and easy. For more information, see page 107-109.

VELUX roller blinds must not be installed in areas with high humidity such as bathrooms.

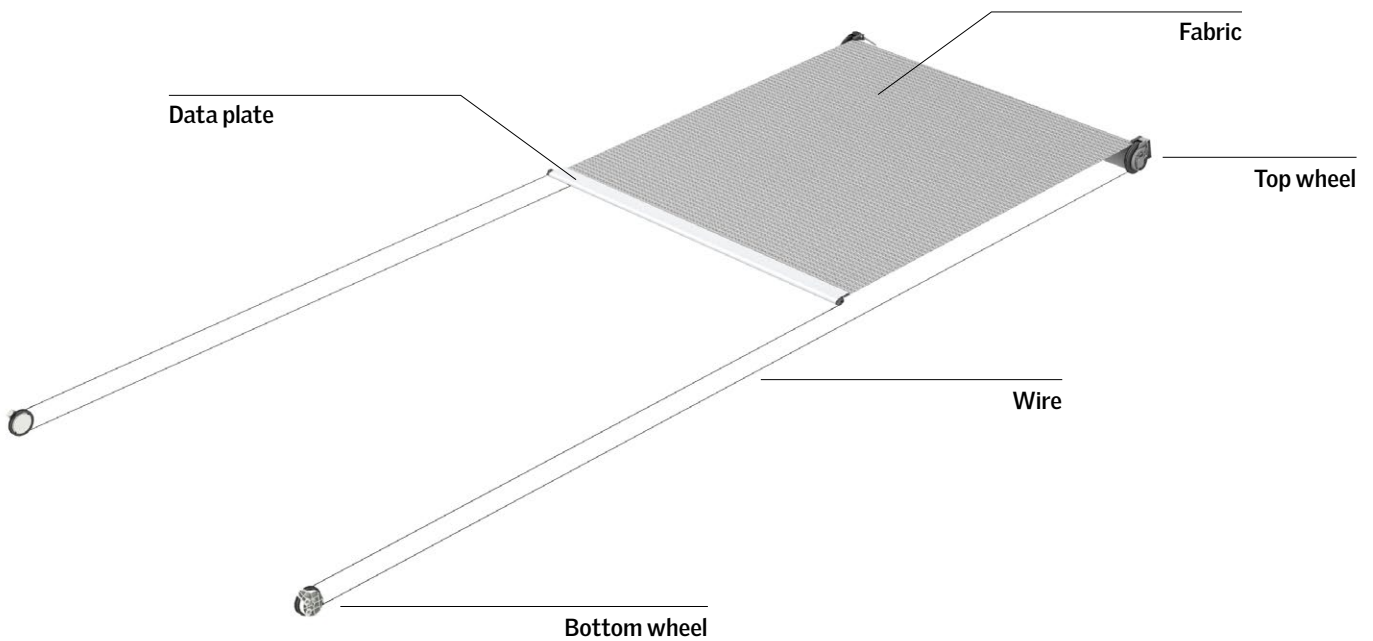

The blind cloth of VELUX roller blinds is pulled on two tension steel wires on pulley wheels, which are accessible, when the roller blinds are installed on skylights within reach and therefore can cause serious injury, if a person gets in contact with this during the electrical operation of the blind. VELUX roller blinds have a recommended minimum installation height of 2.5 m above floor level (inside) and ground level (outside). In case of installation below that level, safety measures must be applied by the installer/user to prevent serious injury. No instruction or measure can eliminate the inherent hazards resulting from installation heights below 2.5 m.

We recommend you to observe national regulations and consider if the planned specific use of the building requires that additional safety measures must be applied by the installer/user to prevent serious injury.

The VELUX Group will not accept responsibility for damages, injury or death resulting from such installation. The installer/user is ultimately responsible for own omissions and actions. Measures could for instance be to install a motion sensor that is able to disconnect power from the control unit in case of any movement in the immediate vicinity of the VELUX Modular Skylights.

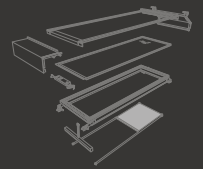

## Fire retardant sun screening

Colour: Variant code	Grey RMM 8805	White RMM 8806	Black RMM 8807

**Order the right size**  
 To order the right sizes see the data plate on the VELUX Modular Skylight.  
 How to read the data plate, see page 43.

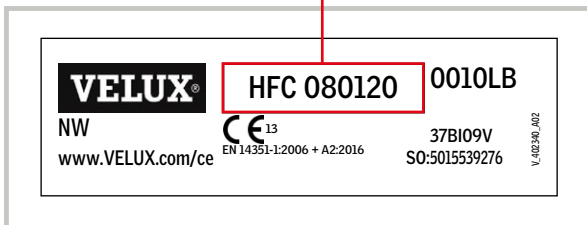

## Beam for Ridgelight at 5°

When installing VELUX Modular Skylights in a 5° Ridgelight solution, the modules are supported by a steel beam. There are two beam design options. You can choose either the horizontal beam with rectangular profile or the parallel beam with curved profile.

The beam is included in the VELUX delivery and is ready for fast and easy installation with no further preparation.

VELUX beams are treated with final coating, white RAL 9010, gloss 30 as standard and are available for modules from 800 to 3000 mm in height.

### Fire resistance

If the beam is required to meet increased demands for fire resistance, for instance used together with a fire resistant skylight module HFS, it must be treated with fire paint. If such a demand occurs, please be advised:

For up to 30 minutes of fire resistance, clients will need to:

- purchase modules with fire resistant glazing units and intumescent strip (HFS).
- purchase the corresponding beam variant coated with fire resistant paint system providing 30 minutes of resistance to fire to the whole application.

Customers are advised to inform the local VELUX sales company of such demands prior to order, as standard beams are not coated with fire resistant paint system but with standard paint as default, and the applied standard paint system is not compatible for post application of fire protection paint systems. Please note that fire paint will change the visual appearance of the beams slightly.

If there are no specific fire rating demands for the modules, but specific demands for the beams, only point b) is relevant.

Always take into consideration that it is only possible to make beams fire rated for up to 30 minutes. If fire rating demands exceed 30 minutes, 5° Ridgelight configurations are not suited for this installation.

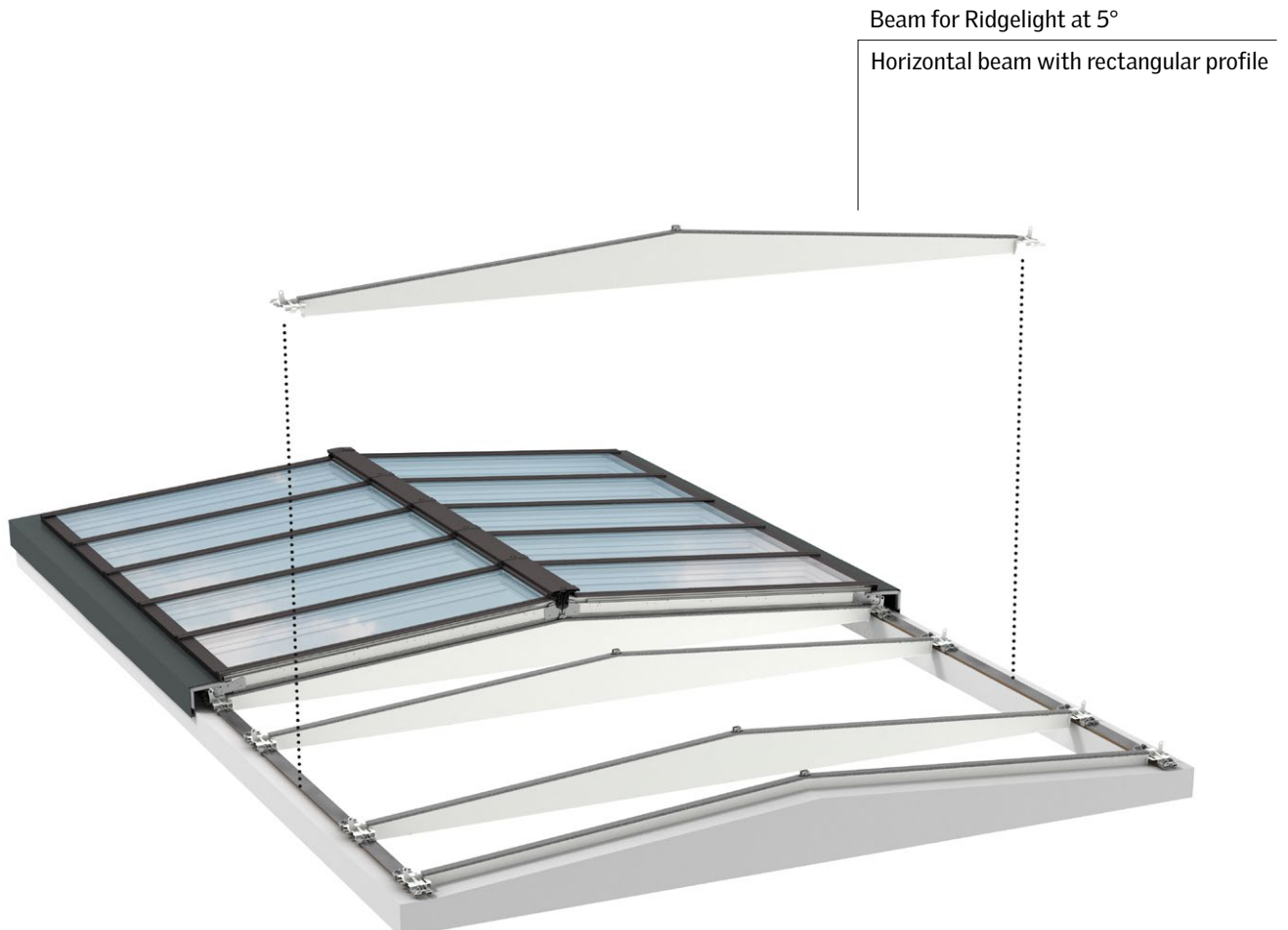

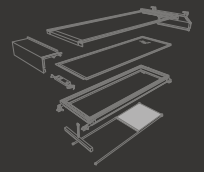

Horizontal beam with rectangular profile



Parallel beam with curved profile

Beam for Ridgelight at 5°

Parallel beam with curved profile

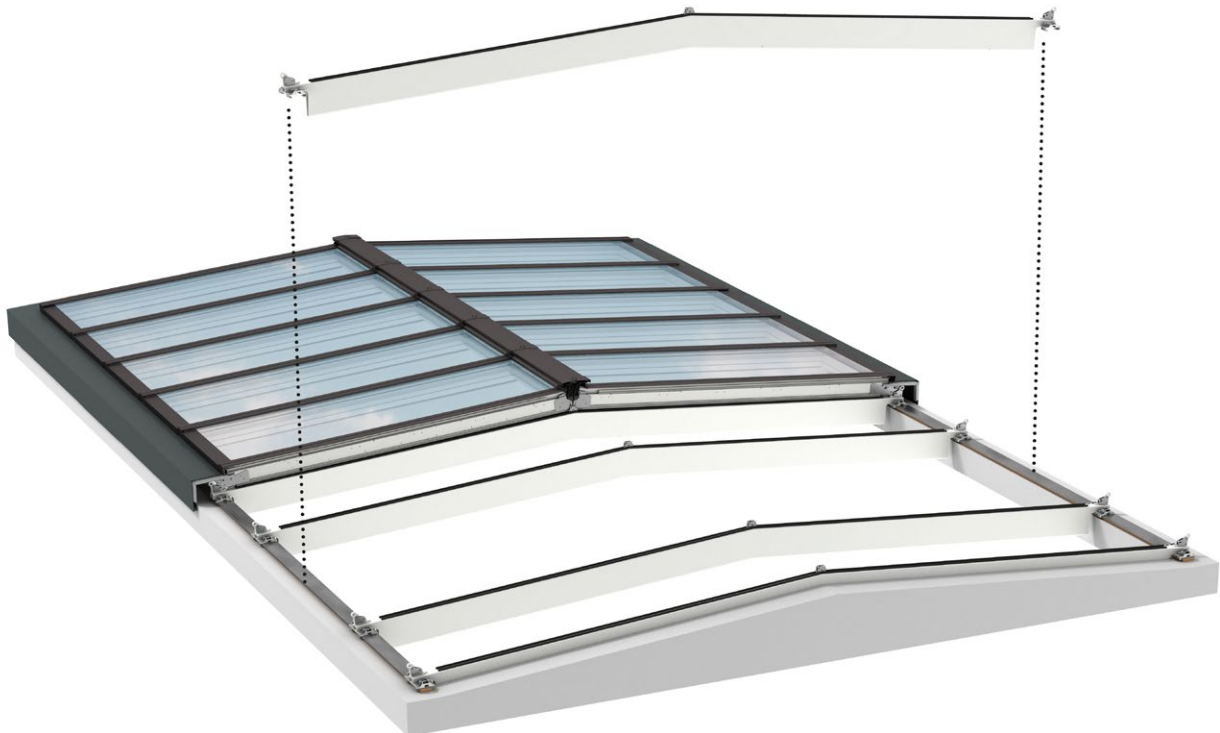



## Wind deflector for smoke ventilation modules

---

The wind deflectors are intended for use with smoke venting modular skylights. The wind deflectors are designed to change the wind profile over the skylights in open position, in order to minimize the risk of air intake and allow outtake of smoke even under unfavorable wind conditions, and at the same time causing the least possible visual effect on the exterior of the skylight. The wind deflectors come in two variants: KCD W00H00 0040 that covers one smoke venting module and KCD 0080 that covers three modules, one smoke venting module in the middle of two fixed modules of the same width.

The deflectors are tested together with VELUX Modular Skylights in accordance with EN 12101-2.

The wind deflector can be purchased and installed at the same time as the smoke ventilator, or they can be installed subsequently, if the skylight configuration allows this. In any case, the aerodynamic free area of the smoke ventilators is declared both with and without wind deflectors and the influence of the deflectors on the performance must be respected.

For further information on the performance of smoke venting modular skylights, the influence of the deflector on the aerodynamic free area and the design possibilities, see pages 87-97.

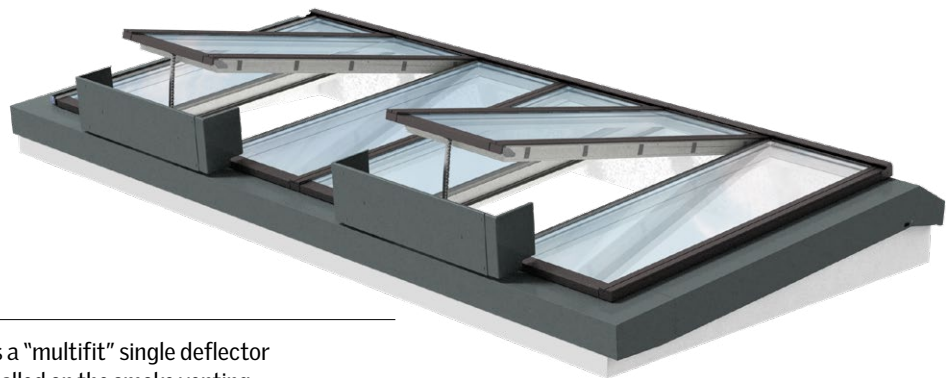

### Wind deflector KCD 0040

---

Wind deflector KCD W00H00 0040 is a "multifit" single deflector for all module sizes. The deflector is installed on the smoke venting module, one deflector for each module.

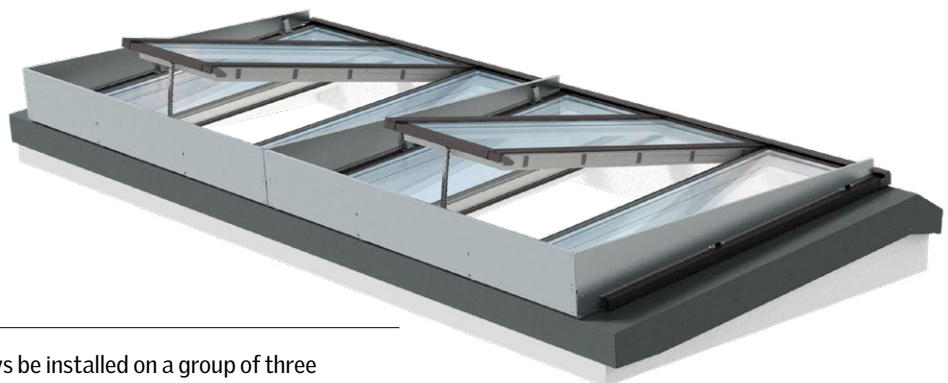

### Wind deflector KCD 0080

---

Wind deflector KCD 0080 must always be installed on a group of three skylight modules with identical width, where the middle module is the smoke ventilator and the two modules at the sides are fixed modules. This deflector is manufactured to fit the size of the three modules it is installed on.

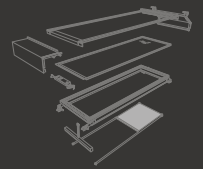

## Data plate

All VELUX Modular Skylights, electrical components and accessory products have a data plate. The data plate helps to identify the product and must NOT be removed.

If a product is damaged or malfunctioning, the information on the data plate must be given to the VELUX sales company.

### Example of data plate and position

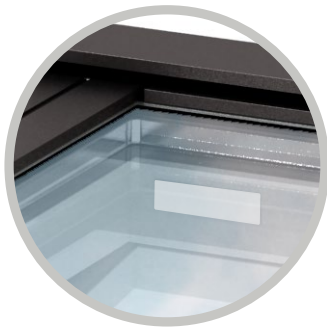
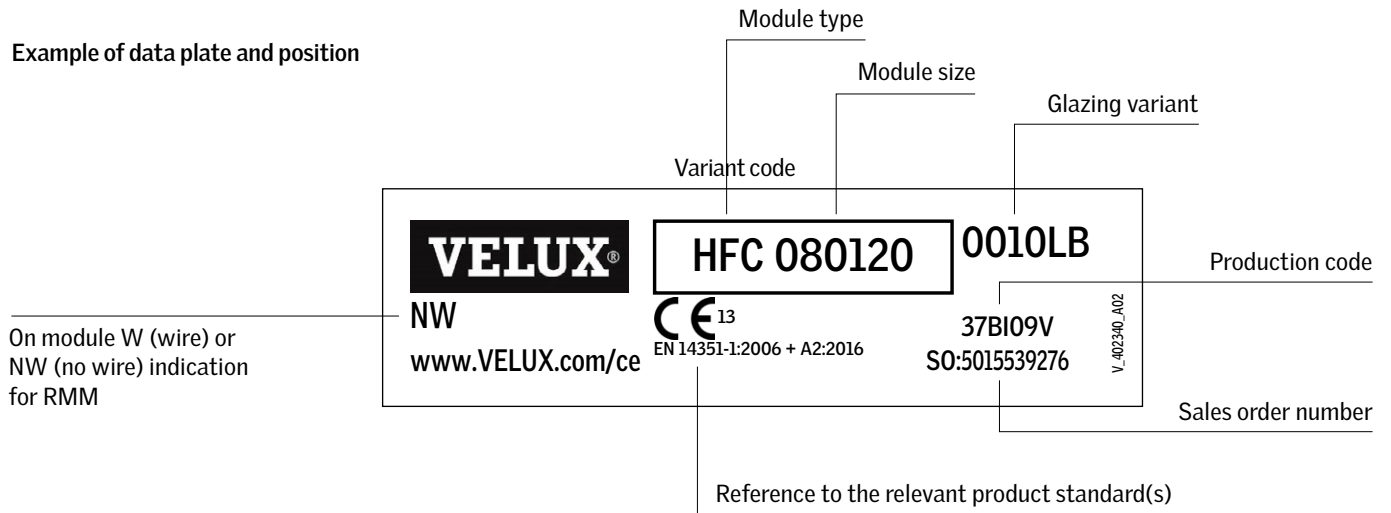















# Solutions

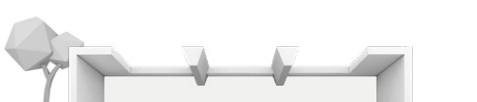

## Quick overview of skylight solutions vs. roof constructions

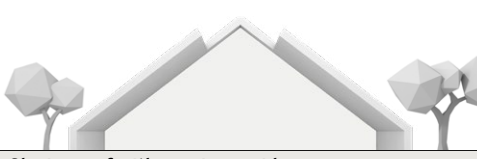





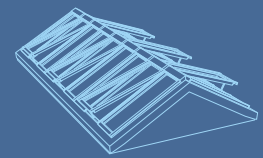

						
Solution*	Longlight		Wall-mounted Longlight	Northlight		
Installation pitch	5-30°		5-45°	25-90°		
HFC = fixed modules, HVC = venting modules	HFC	HVC	HFC	HVC	HFC	HVC
Opening width (Length = ∞) **	0.6 - 3.1 m	0.8 - 2.5 m	0.6 - 3.2 m	0.8 - 2.6 m	0.6 - 3.1 m	0.8 - 2.5 m
 1.2 - 2.5 m > <	✓					
Flat roof with small opening						
 2.0 - 4.5 m > <	✓					
Flat roof with medium opening						
 3.2 - 6.2 m > <						
Flat roof with large opening						
						
Flat roof with extra large opening (Atrium)						
			✓			
Flat roof up against a wall						
					✓	
Northlight						
	✓				✓	
Sloping roof with opening in the side						
						
Sloping roof with opening as ridge						

\* Please note that all solutions, regardless of roof construction, require installation on a sub-construction designed according to instructions given by the VELUX Group.

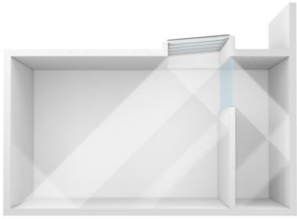

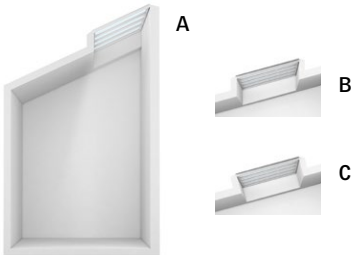
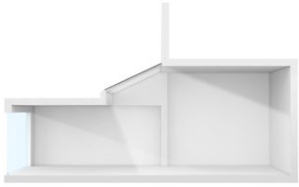

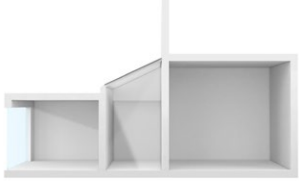

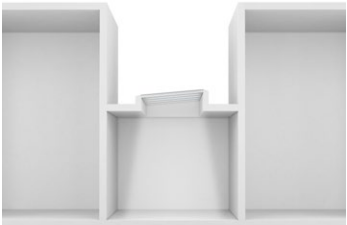
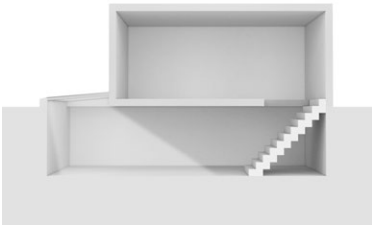



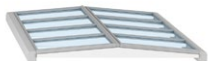
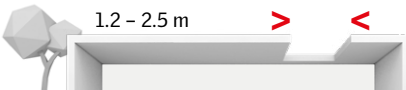

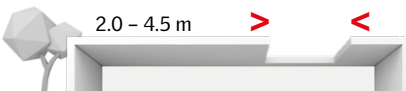

\*\* Measurements are guidelines only. Exact numbers will be supplied by your VELUX sales company.

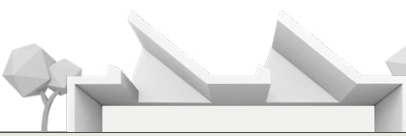

## Idea catalogue on alternative construction possibilities and light distribution

		
Longlight	Wall-mounted Longlight	Northlight
		
Daylight in both an office and a corridor	Newbuild extension with wall-mounted solution	Daylight will be restricted in a 90° solution
		
Asymmetric room with a sloping roof	Buildings with different heights	A lower pitch creates more daylight inside
		
When a sloping roof cannot carry a Ridgeline	Opens up a corridor in a building	Northlight integrated in the roof construction
		
In a shaft between two buildings	Daylight into a basement	

## Quick overview of skylight solutions vs. roof constructions



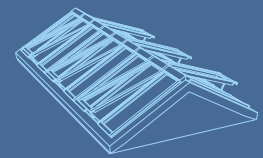

				
Solution*	Ridgelight		Ridgelight at 5° with Beams	
Installation pitch	25-40°		5°	
HFC = fixed modules, HVC = venting modules	HFC	HVC	HFC	HVC
Opening width (Length = ∞) **	1.4 - 4.5 m	1.4 - 4.5 m	1.8 - 6.2 m	1.8 - 5.0 m
 1.2 - 2.5 m > <				
Flat roof with small opening				
 2.0 - 4.5 m > <				
Flat roof with medium opening				
 3.2 - 6.2 m > <				
Flat roof with large opening				
				
Flat roof with extra large opening (Atrium)				
				
Flat roof up against a wall				
				
Northlight				
				
Sloping roof with opening in the side				
				
Sloping roof with opening as ridge				

\* Please note that all solutions, regardless of roof construction, require installation on a sub-construction designed according to instructions given by the VELUX Group.

\*\* Measurements are guidelines only. Exact numbers will be supplied by your VELUX sales company.

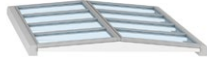





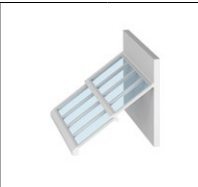
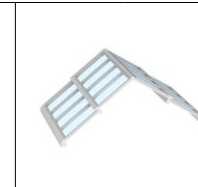
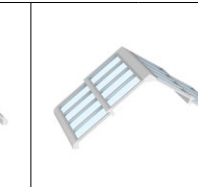

Idea catalogue on alternative construction possibilities and light distribution

	
<p>Ridgelight</p>	<p>Ridgelight at 5° with Beams</p>
	
<p>On top of a sloping roof</p>	<p>Solution for flat roof with a wide opening</p>
	
<p>Asymmetric Ridgelight with infill panel on south side blocking the excess sun</p>	

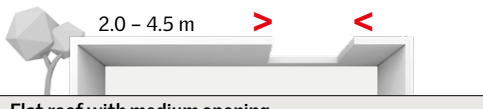
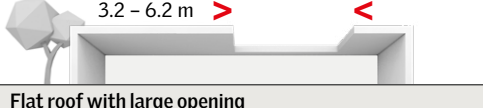
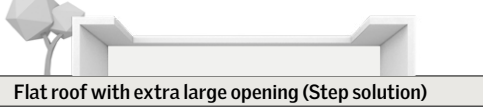



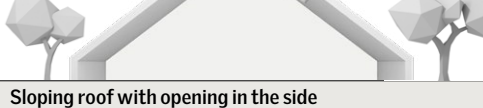

## Quick overview of skylight solutions vs. roof constructions

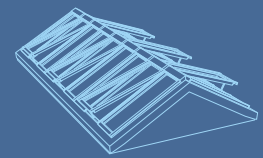
				
Solution*	Step Longlight	Step Wall-mounted Longlight	Step Ridgelight	Step Ridgelight on Girder
Installation pitch	5-25°		25°	
HFC = fixed modules, HVC = venting modules	HFC	HVC	HFC	HVC
Opening width (Length = ∞) **	2.6 – 18 m	2.6 – 18 m	4.5 – 33 m	6 – 36 m
 1.2 – 2.5 m				
Flat roof with small opening				
 2.0 – 4.5 m				
Flat roof with medium opening				
 3.2 – 6.2 m				
Flat roof with large opening				
	✓		✓	✓
Flat roof with extra large opening (Step solution)				
		✓		
Flat roof up against a wall				
				
Northlight				
	✓			
Sloping roof with opening in the side				
			✓	✓
Sloping roof with opening as ridge				





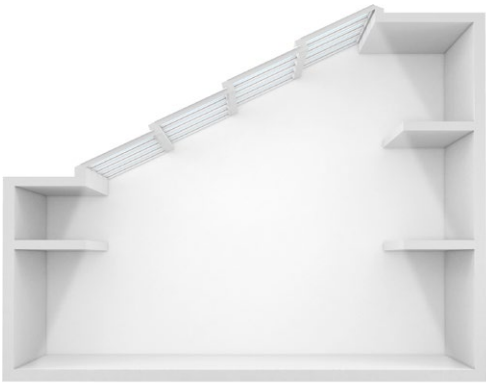
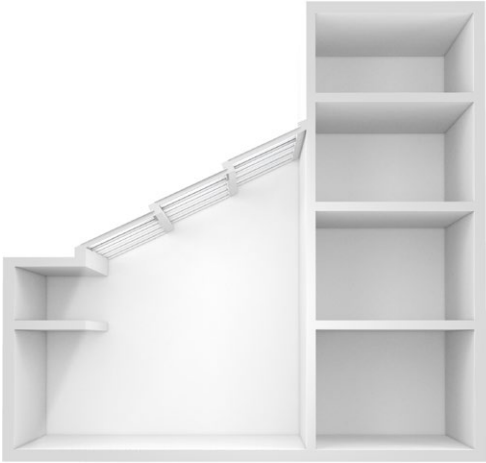
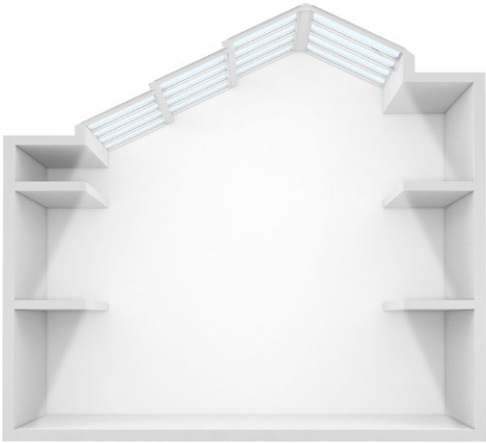
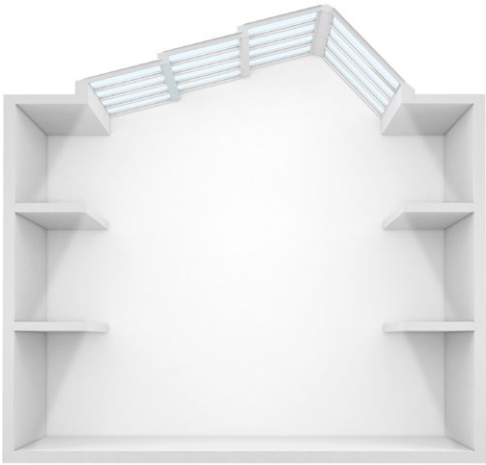

\* Please note that all solutions, regardless of roof construction, require installation on a sub-construction designed according to instructions given by the VELUX Group.  
 \*\* Measurements are guidelines only. Exact numbers will be supplied by your VELUX sales company.

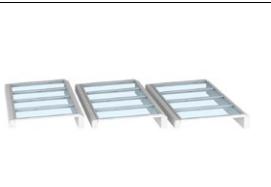
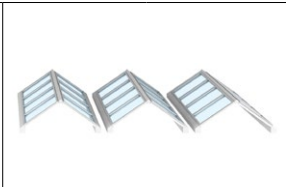
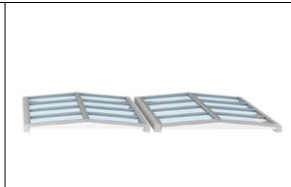

Idea catalogue on alternative construction possibilities and light distribution

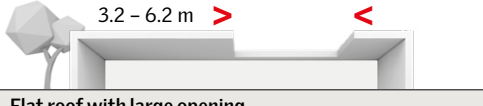
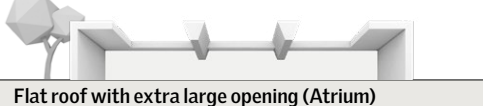
			
Step Longlight	Step Wall-mounted Longlight	Step Ridgelight	Step Ridgelight on Girder
		<p>A roof in two levels with Step Longlight</p>	<p>Two buildings in different height connected by a Step Wall-mounted Longlight</p>
		<p>A roof in two levels with Step Ridgelight on Girder</p>	<p>A flat roof with a Step Ridgelight on Girder</p>

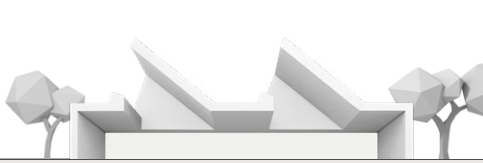
## Quick overview of skylight solutions vs. roof constructions

						
Solution*	Atrium Longlight		Atrium Ridgelight		Atrium Ridgelight at 5° with Beams	
Installation pitch	5-30°		25-40°		5°	
HFC = fixed modules, HVC = venting modules	HFC	HVC	HFC	HVC	HFC	HVC
Opening width (Length = ∞) **	0.6 - 3.1 m	0.8 - 2.5 m	1.4 - 4.5 m	1.4 - 4.5 m	1.8 - 6.2 m	1.8 - 5.0 m
 1.2 - 2.5 m > <						
Flat roof with small opening						
 2.0 - 4.5 m > <						
Flat roof with medium opening						
 3.2 - 6.2 m > <						
Flat roof with large opening						
 ✓	✓		✓		✓	
Flat roof with extra large opening (Atrium)						
						
Flat roof up against a wall						
						
Northlight						
						
Sloping roof with opening in the side						
						
Sloping roof with opening as ridge						

\* Please note that all solutions, regardless of roof construction, require installation on a sub-construction designed according to instructions given by the VELUX Group.

\*\* Measurements are guidelines only. Exact numbers will be supplied by your VELUX sales company.

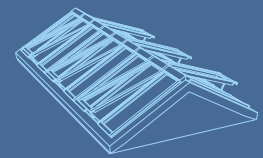

## Idea catalogue on alternative construction possibilities and light distribution

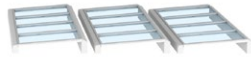

Atrium Longlight



Atrium Ridgelight



Atrium Ridgelight at 5°  
with Beams

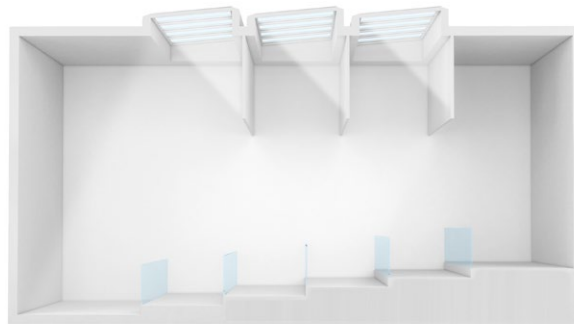

Atrium Longlight with internal sun screening. Design ideas like internal vertical sun screening are not supplied by the VELUX Group

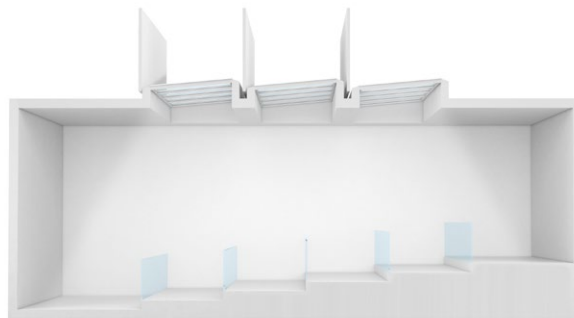

Atrium Longlight with external sun screening. Design ideas like vertical sun screening are not supplied by the VELUX Group

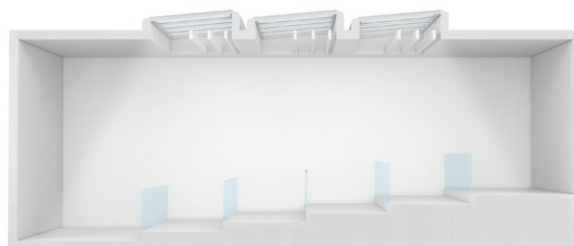

Atrium Longlight with sun louvres. Design ideas like sun louvres are not supplied by the VELUX Group



# Longlight 5-30°

Longlights are bands of VELUX Modular Skylights, supplied with installation brackets and clamps that guarantee a fast and secure installation. The prefabricated flashing allows for configurations with a pitch of 5 to 30°.

Longlights are mounted on a standard steel profile, 100 mm wide (not a VELUX component). The brackets are fixed with a clamping system holding the skylights in place. It is also possible to install the mounting brackets of a Longlight directly onto a wooden batten without using the clamps.

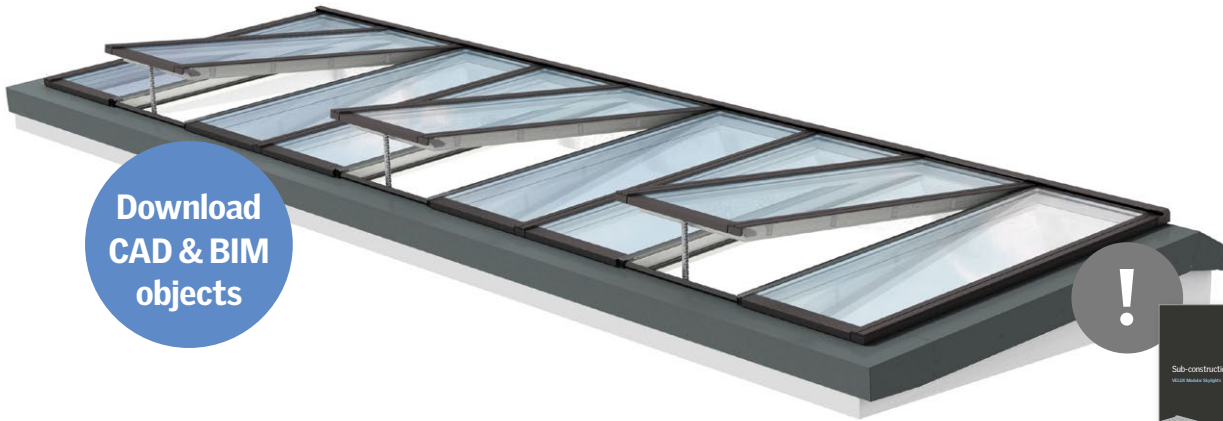

Download  
CAD & BIM  
objects

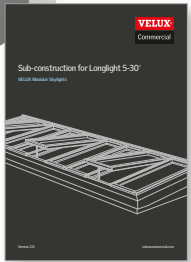

Sub-construction  
for Longlight at:  
[veluxcommercial.com](http://veluxcommercial.com)

Use the table to define module height (H) and/or installation pitch (α).

Example:  
A = 1875 mm

Result:  
α1: H = 1800 mm at an installation pitch of 13°  
or  
α2: H = 2000 mm at an installation pitch of 28°

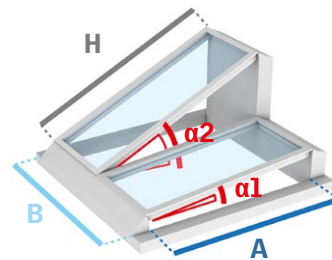

H: Module height  
α: Installation pitch  
A: Opening width  
B: Opening length

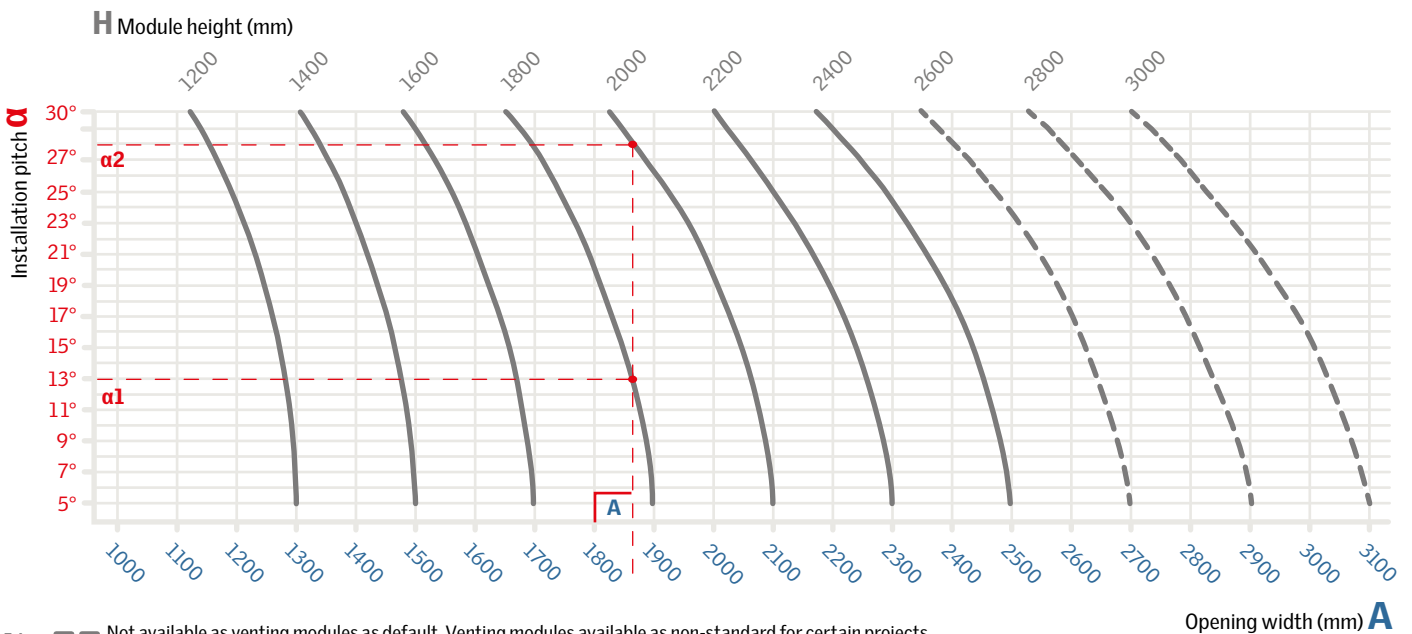

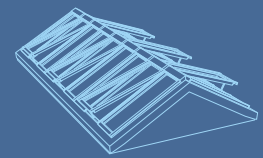

## Sectional drawings

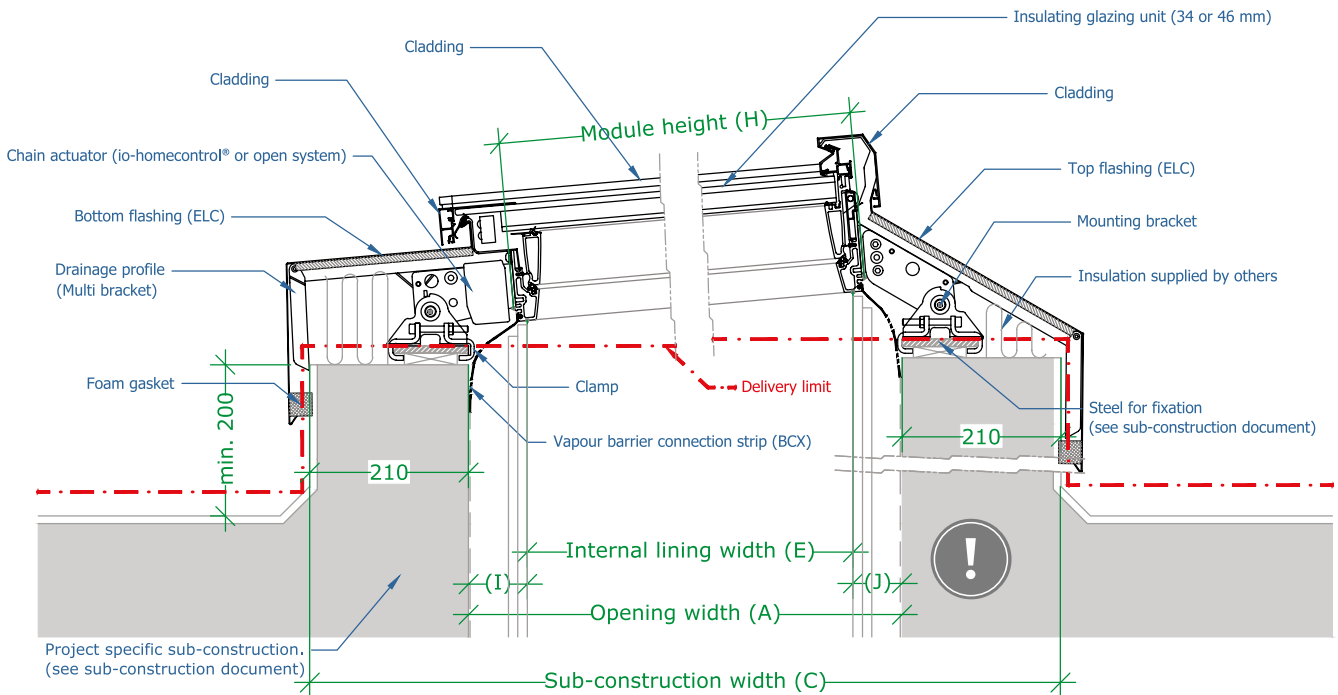

Cross-section - bottom

Cross-section - top

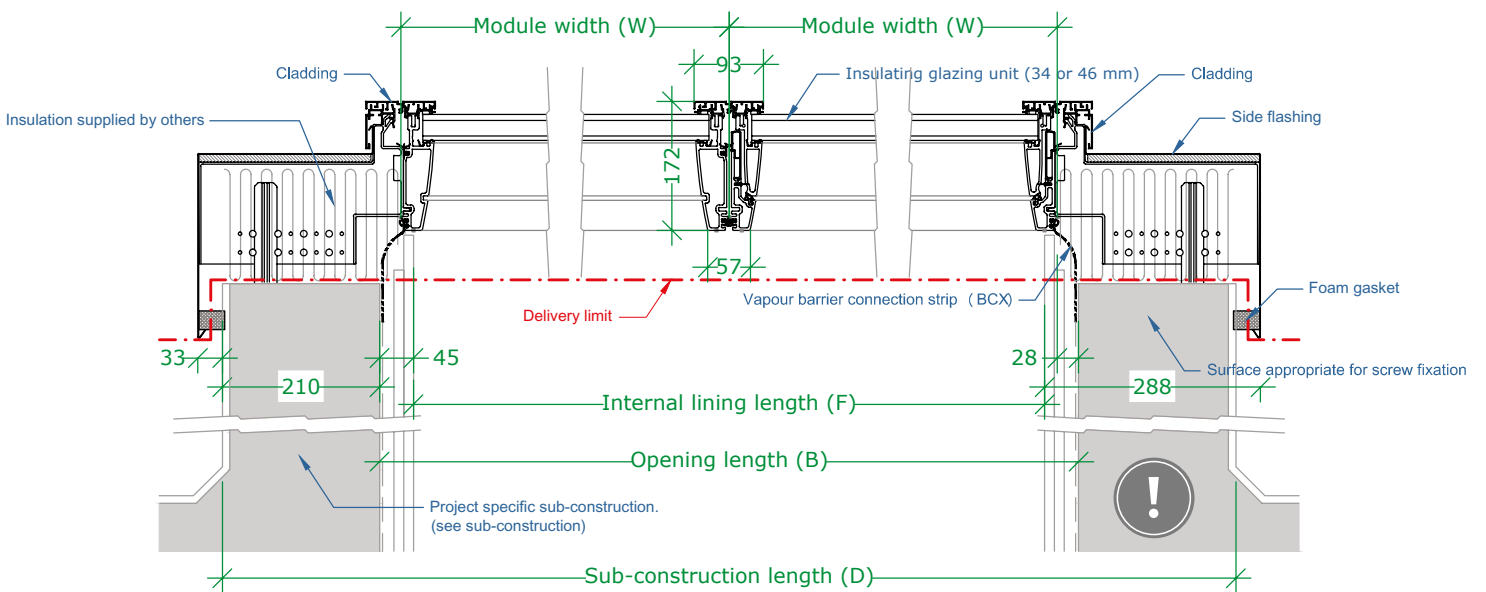

Longitudinal section

Please observe that a lateral slope on the modules is NOT possible, therefore top and bottom sub-construction must be horizontal.

# Wall-mounted Longlight 5-45°

Wall-mounted Longlights are bands of VELUX Modular Skylights mounted against a vertical wall. As the skylight modules are supplied with installation brackets and clamps, a fast and secure installation is guaranteed. The flashing allows for configurations with a pitch of 5° to 45°.

Wall-mounted Longlights are mounted on a standard steel profile, 100 mm wide at the wall. At the bottom, you can choose to mount the skylights on either a steel profile using the clamping system or directly onto a wooden batten without using the clamps. The steel profiles and wooden battens are not VELUX components. Please observe a max. 3 m wall height above skylight module.



Download  
CAD & BIM  
objects



Sub-construction for  
Wall-mounted Longlight at:  
[veluxcommercial.com](http://veluxcommercial.com)

Use the table to define module height (H) and/or installation pitch (α).

Example:  
A = 1700 mm

Result:  
α1: H = 1600 mm at an installation pitch of 20°  
or  
α2: H = 1800 mm at an installation pitch of 31°  
or  
α3: H = 2000 mm at an installation pitch of 39°  
or  
α4: H = 2200 mm at an installation pitch of 44°

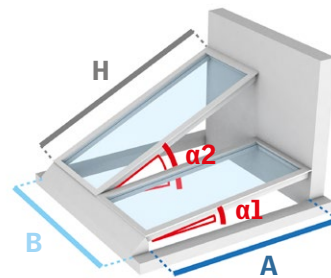

H: Module height  
α: Installation pitch  
A: Opening width  
B: Opening length

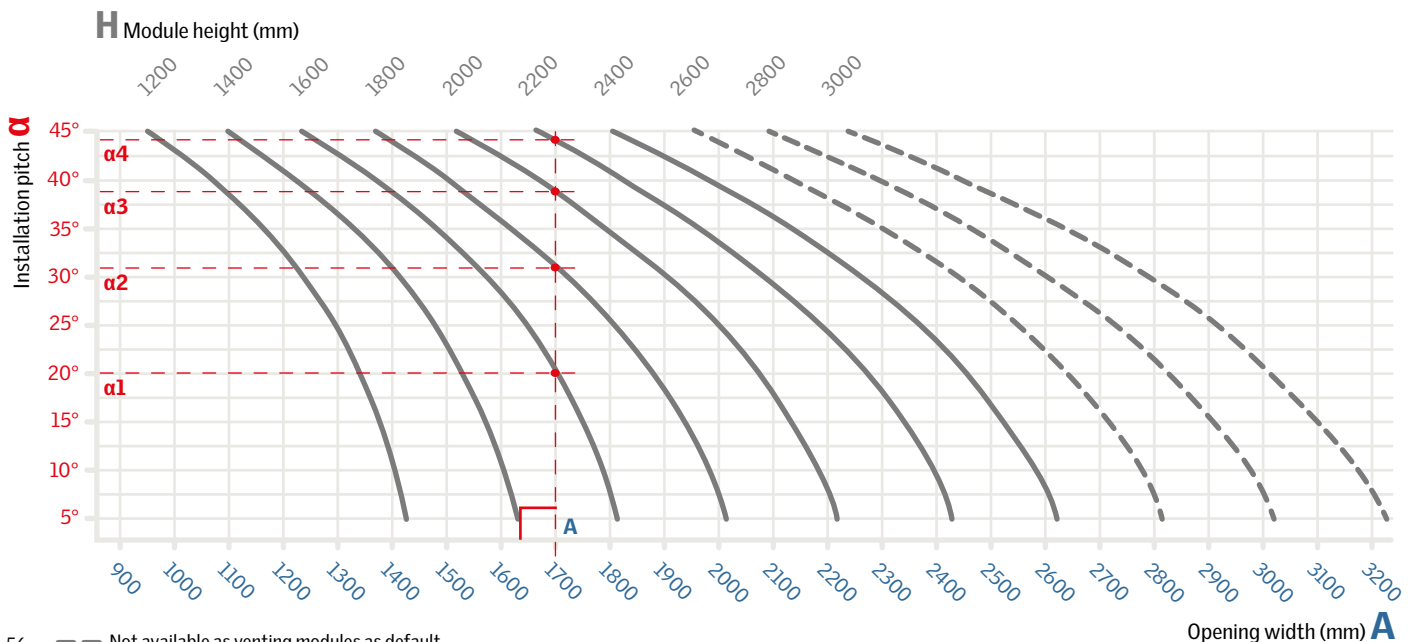

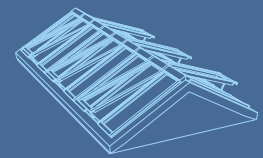

# Sectional drawings

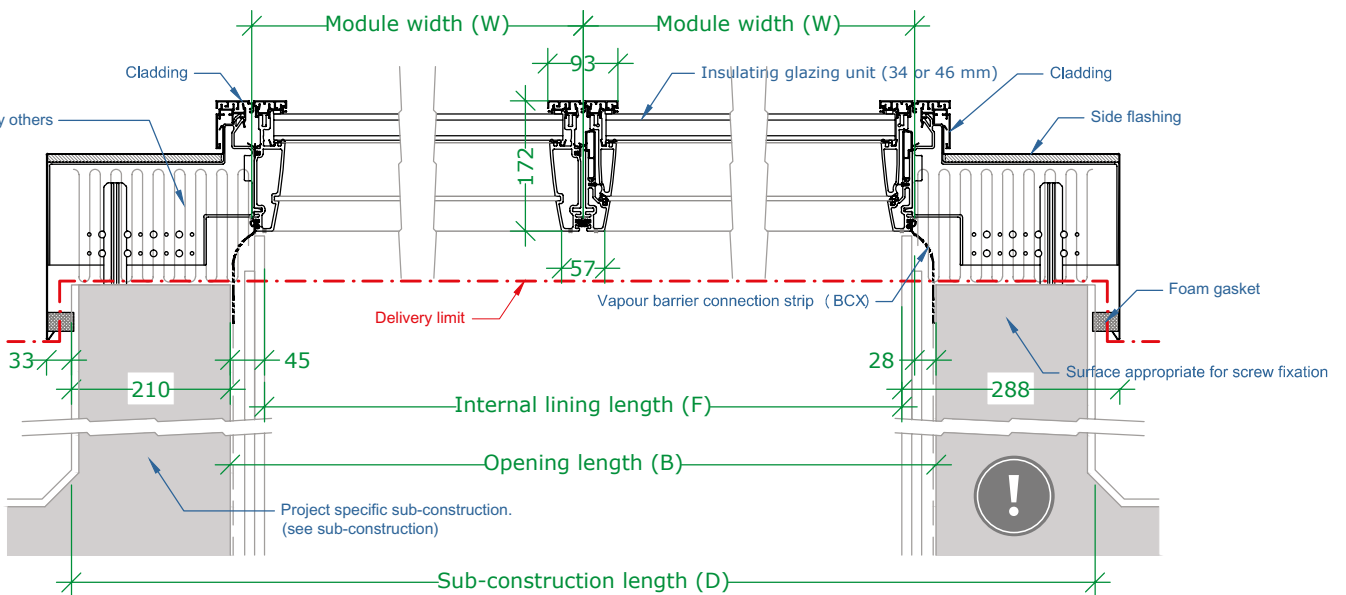
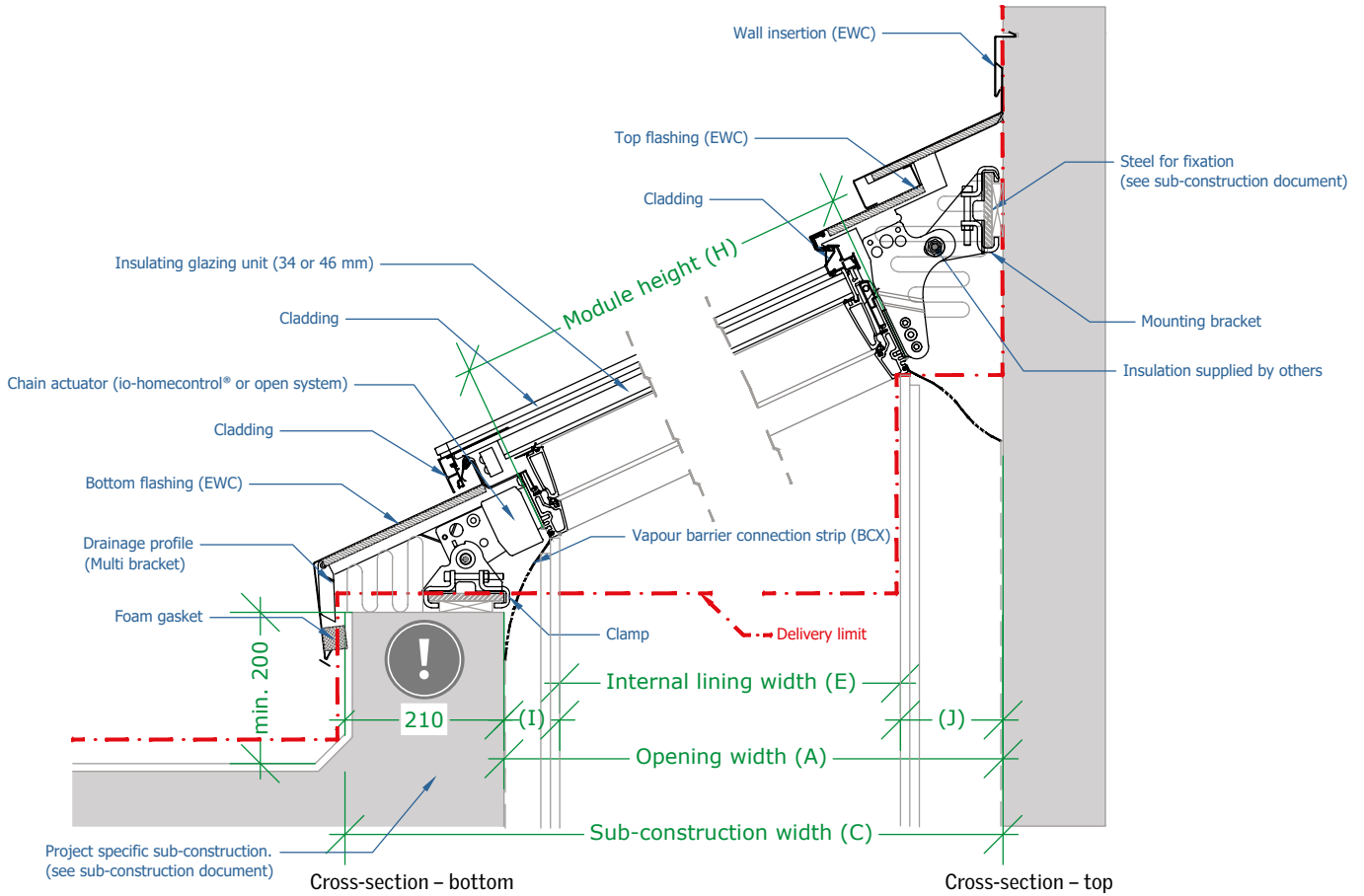

Longitudinal section

Please observe that a lateral slope on the modules is NOT possible, therefore top and bottom sub-construction must be horizontal.



# Northlight 25-90°

Similar to Longlights, Northlights are bands of VELUX Modular Skylights. The characteristic upright design is primarily for installations that are directed towards the northern hemisphere for soft and reflected lighting. Northlight installations are applicable for a pitch of 25 to 90°.

At the bottom, Northlights are mounted on a standard steel profile, 100 mm wide (not a VELUX component) and fixed with clamps holding the skylight in place. At the top, the brackets are fixed to the sub-construction with screws meant for wood.

The prefabricated modular flashing ensures easy integration in the roof surface. All flashings are easily installed. The roof surface underneath the flashing must be appropriate for screw fixation.

Please observe a max. 10 m wall height above skylight module, when installed in a sloped roof. Take notice that the top flashing changes in size above and below 54°, see sectional drawing page 59.

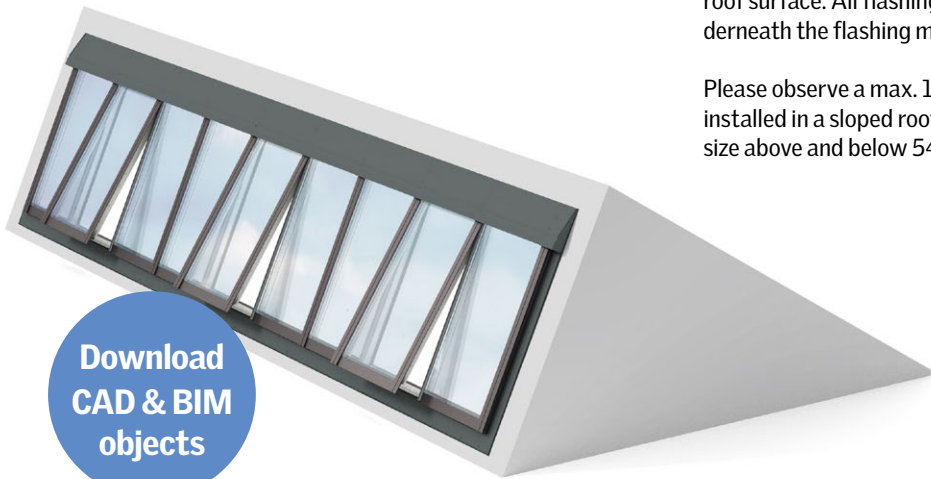

Download  
CAD & BIM  
objects

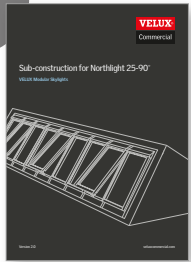

Sub-construction for  
Northlight at:  
veluxcommercial.com

## Defining module size to your project

Example:

$\alpha_1$ : H = 1600 mm at an installation pitch of 50°

$A_{max}$  = 1680 mm  
 $A_{min}$  = 1566 mm

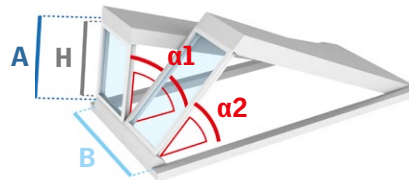

- H: Module height
- $\alpha$ : Installation pitch
- A: Opening width
- B: Opening length

Installation pitch  $\alpha$

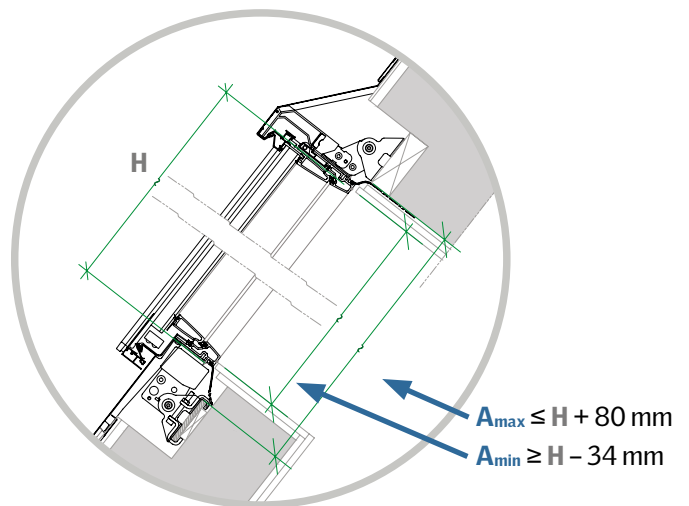
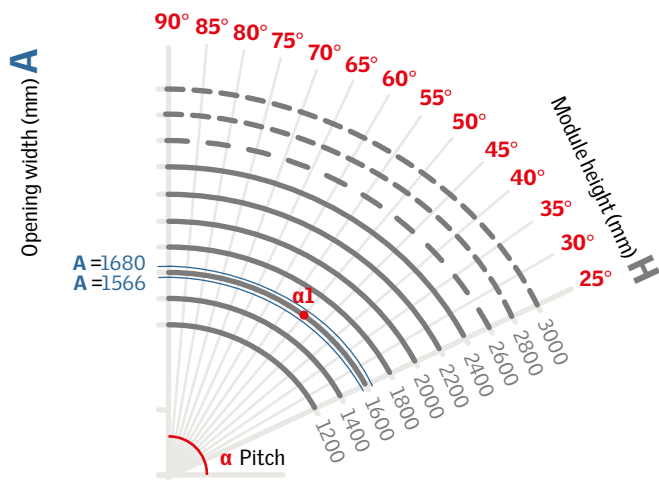

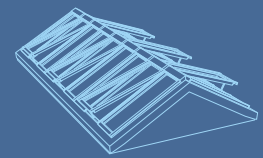

# Sectional drawings

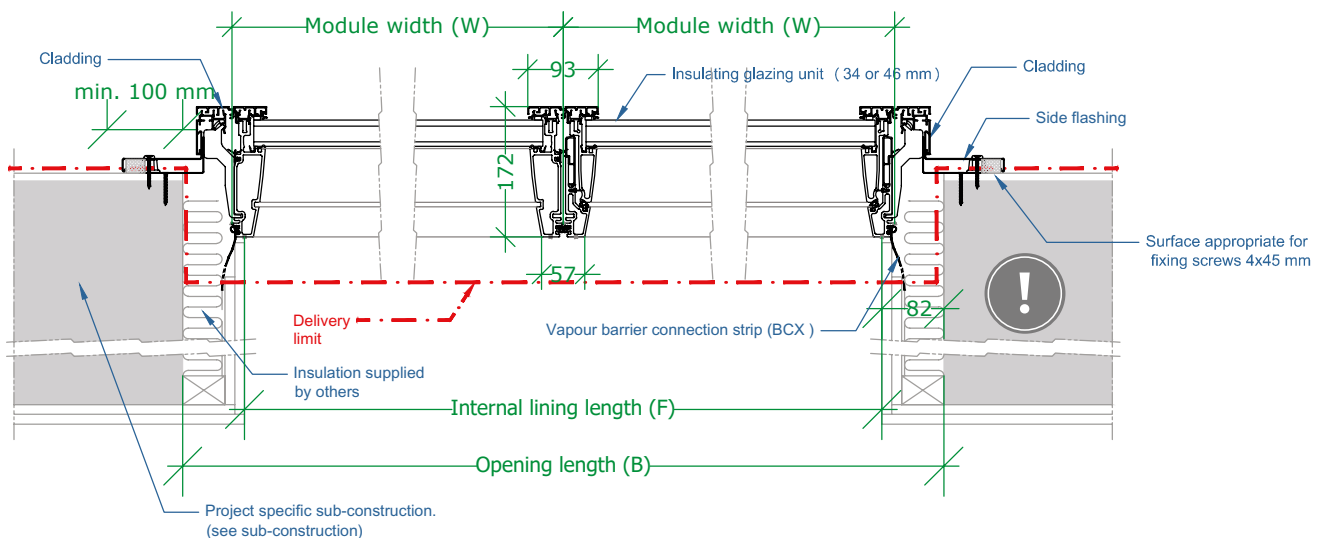
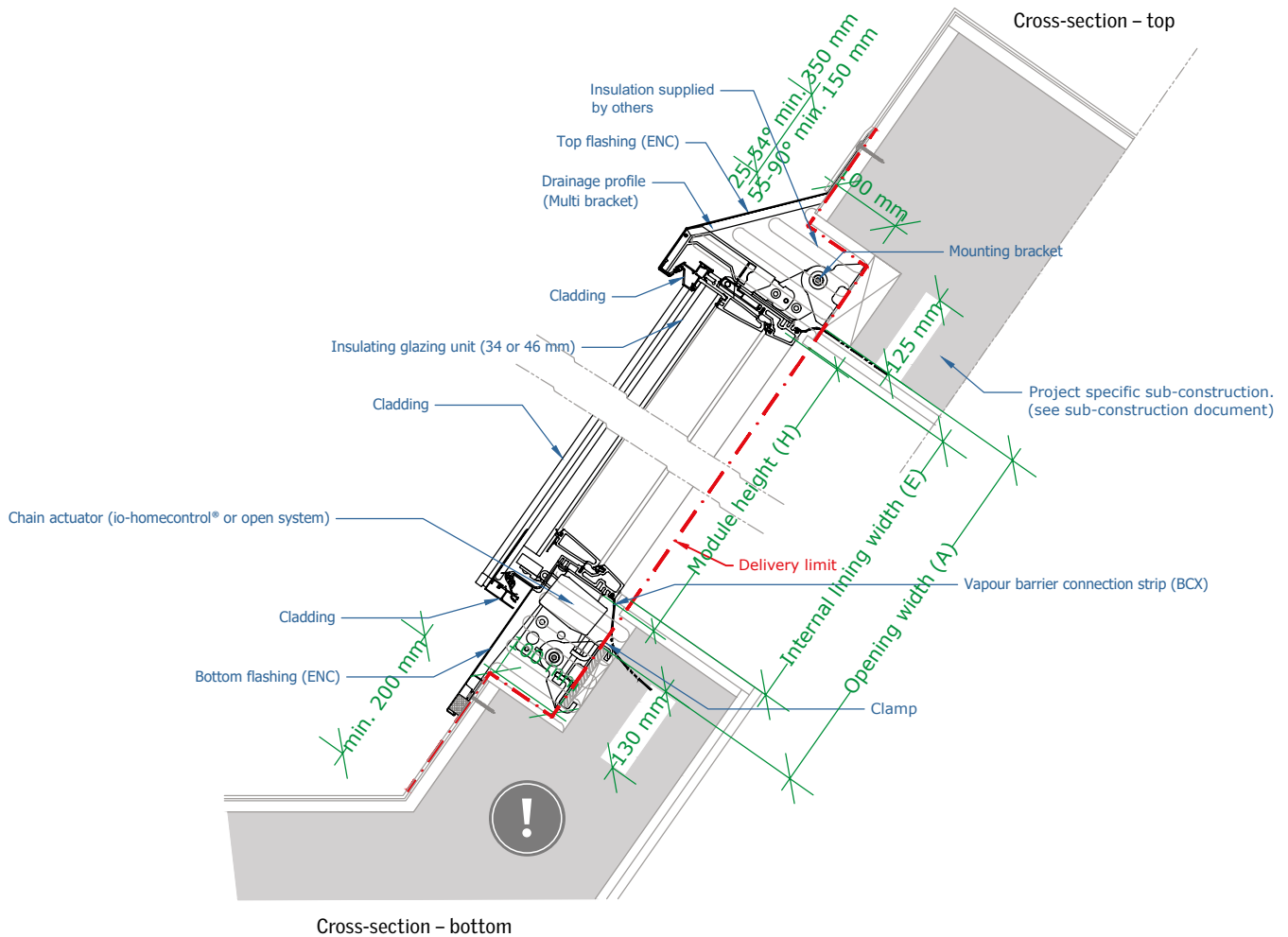

Please observe that a lateral slope on the modules is NOT possible, therefore top and bottom sub-construction must be horizontal.

# Ridgelight 25-40°

Ridgelight is a classic solution, consisting of two rows of skylights linked together at the ridge, creating a self-supporting structure. The flashing allows for installations with a pitch of 25 to 40°.

Due to horizontal forces, it is recommended to use a sub-construction of steel or concrete when mounting a Ridgelight. Ridgelights are mounted on a standard steel profile, 100 mm wide (not a VELUX component). The brackets are fixed with a clamping system holding the skylights in place. It is not recommended to fasten the mounting brackets of a Ridgelight directly onto a wooden batten with screws.

Please observe that it is the designers responsibility to calculate the correct number and size of fixing if a wooden batten is used.

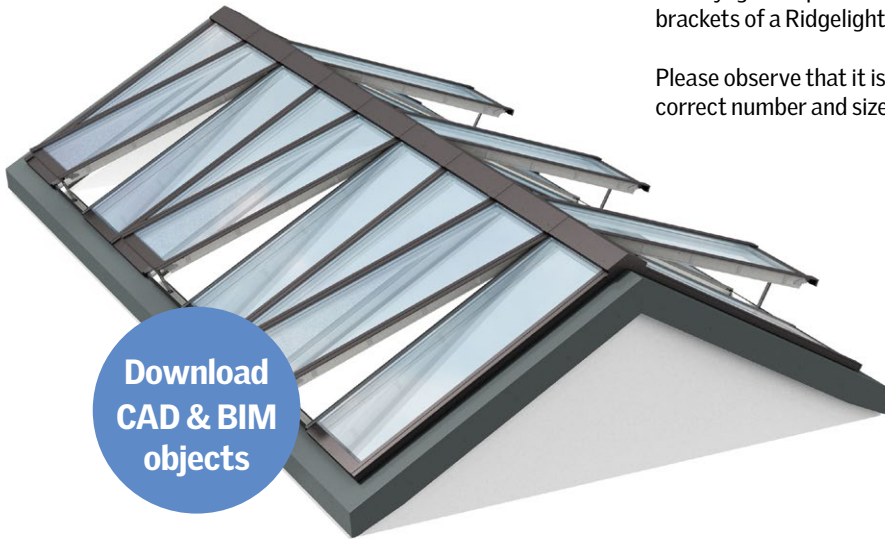

Download  
CAD & BIM  
objects

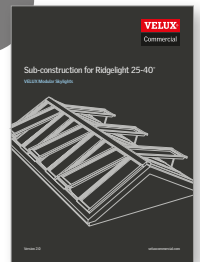

Sub-construction  
for Ridgelight at:  
[veluxcommercial.com](http://veluxcommercial.com)

Use the table to define module height (H) and/or installation pitch (α).

Example:  
A = 3775 mm

Result:  
α1: H = 2000 mm at an installation pitch of 26°  
or  
α2: H = 2200 mm at an installation pitch of 35.5°

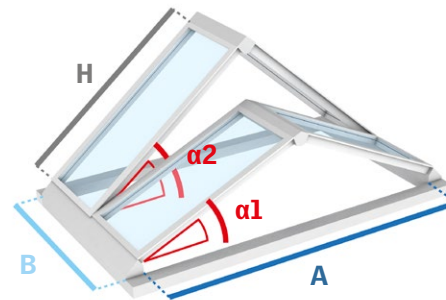

H: Module height  
α: Installation pitch  
A: Opening width  
B: Opening length

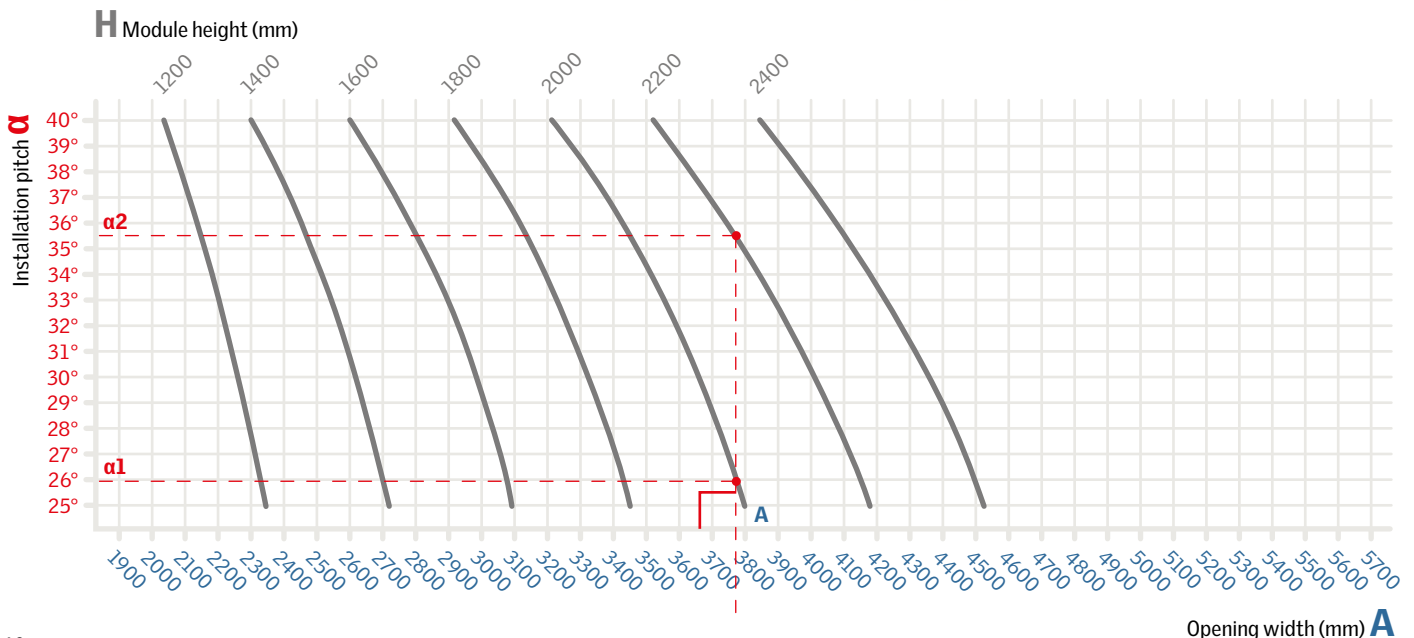

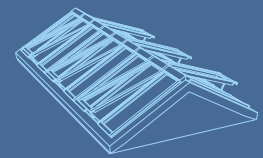

## Sectional drawings

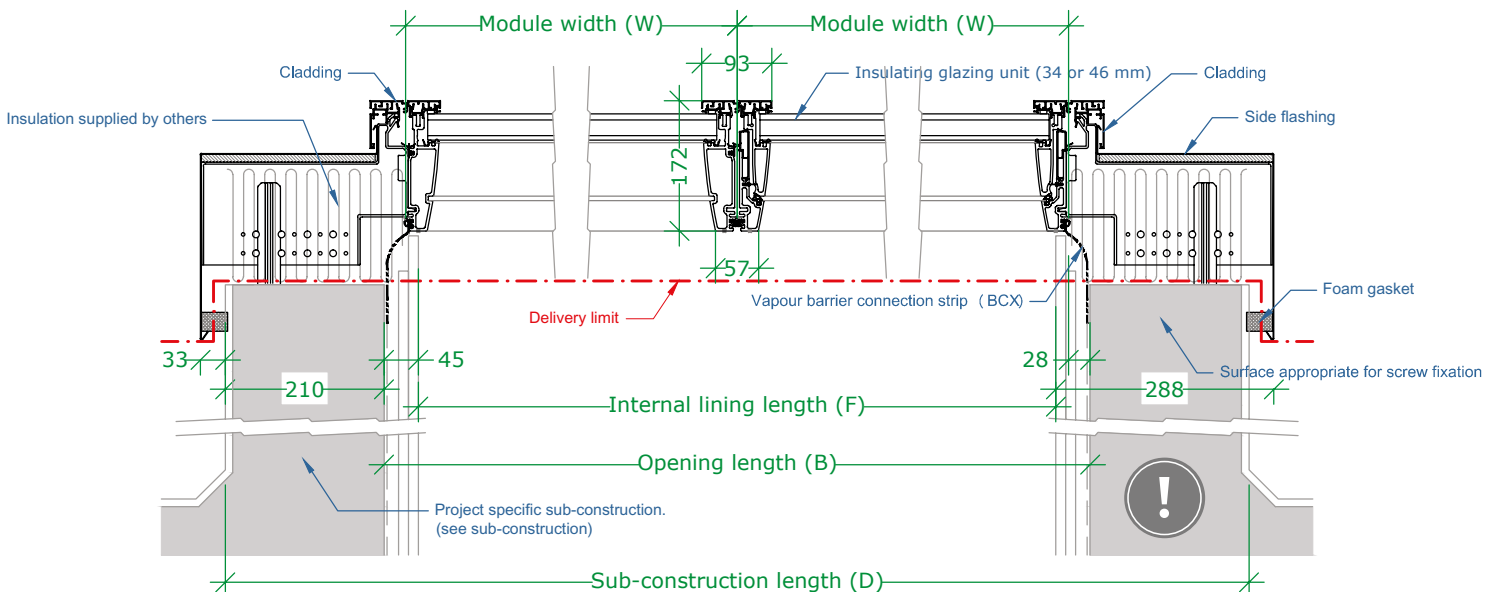
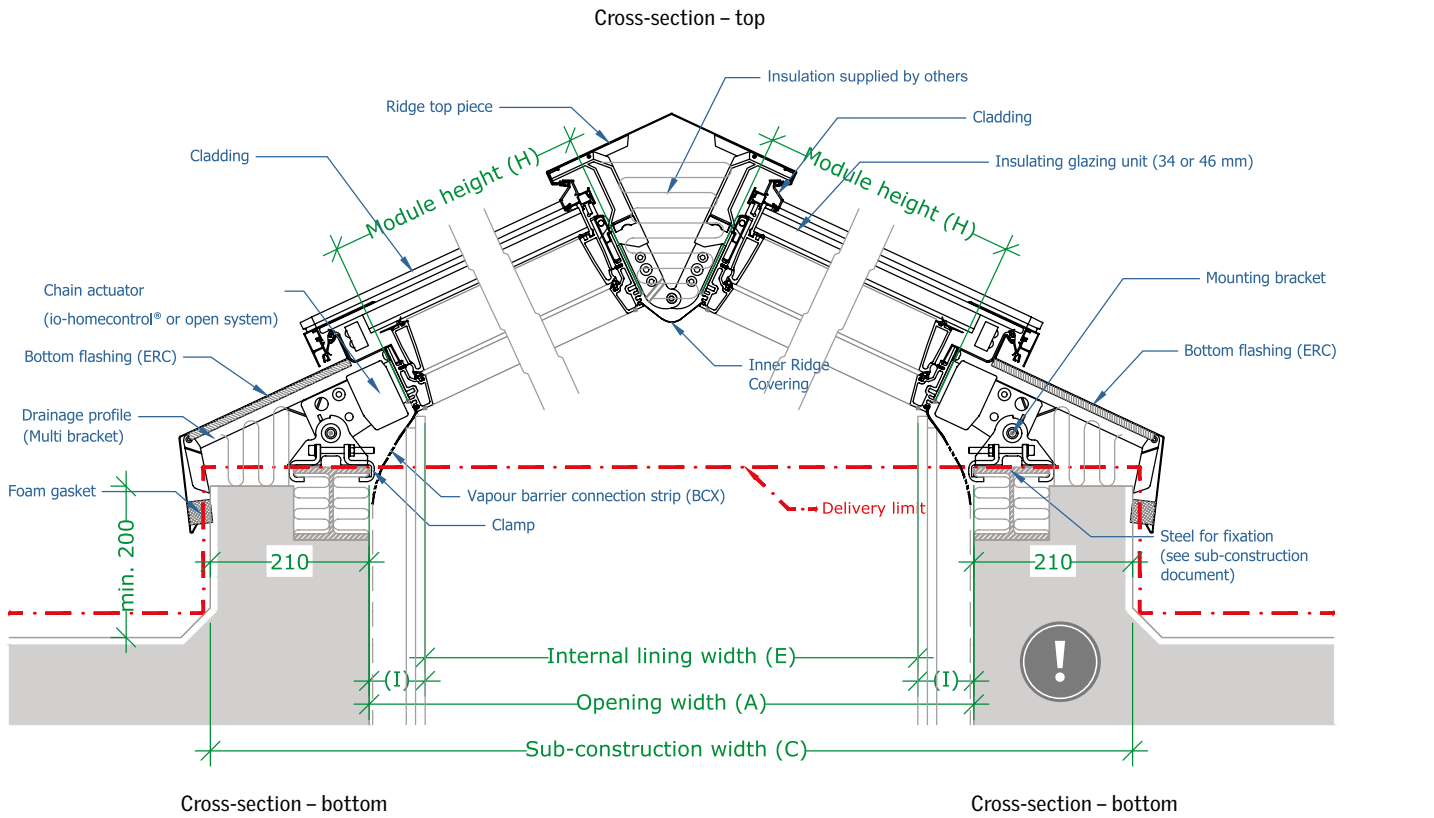

Please observe that a lateral slope on the modules is NOT possible, therefore top and bottom sub-construction must be horizontal.

# Ridgelight at 5° with Beams (Horizontal beam with rectangular profile)

Ridgelights at 5° pitch guarantee the illusion of a small glass roof with discreet transverse horizontal supporting beams. The prefabricated VELUX beam supports the skylights and creates

the 5° pitch. The beams are mounted on a standard steel profile, 100 mm wide (not a VELUX component), on top of the sub-construction.

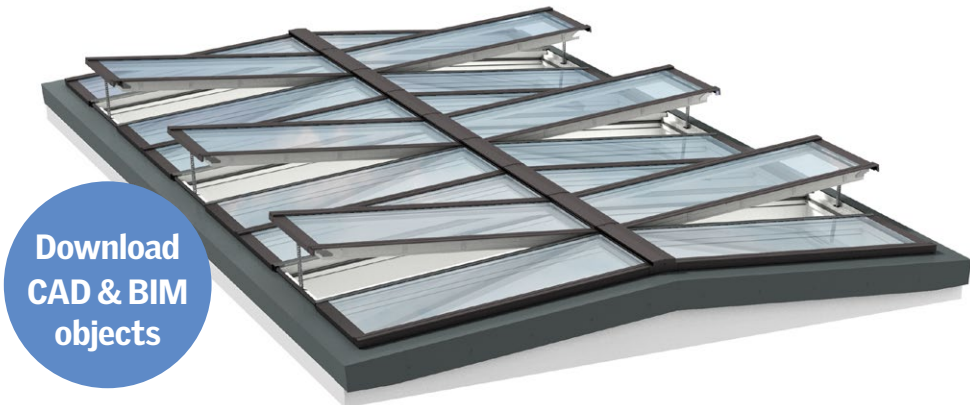

Download  
CAD & BIM  
objects

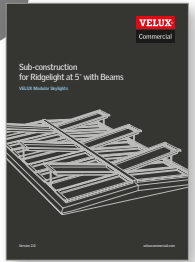

Sub-construction for  
Ridgelight at 5° with Beams at:  
[veluxcommercial.com](http://veluxcommercial.com)

Use the table to define module height (H) and/or installation pitch (α).

Example:  
A = 4975 mm

Result:  
α: H = 2400 mm at an installation pitch of 5°

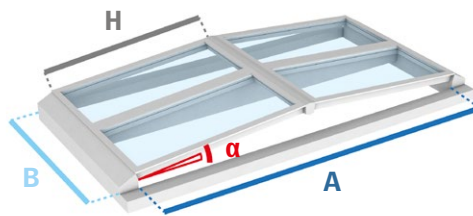

- H: Module height
- α: Installation pitch
- A: Opening width
- B: Opening length

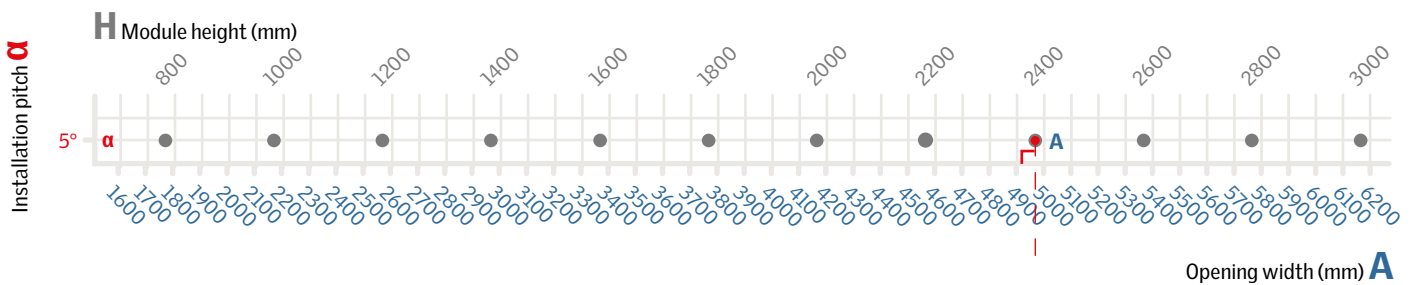



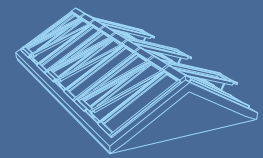

## Sectional drawings

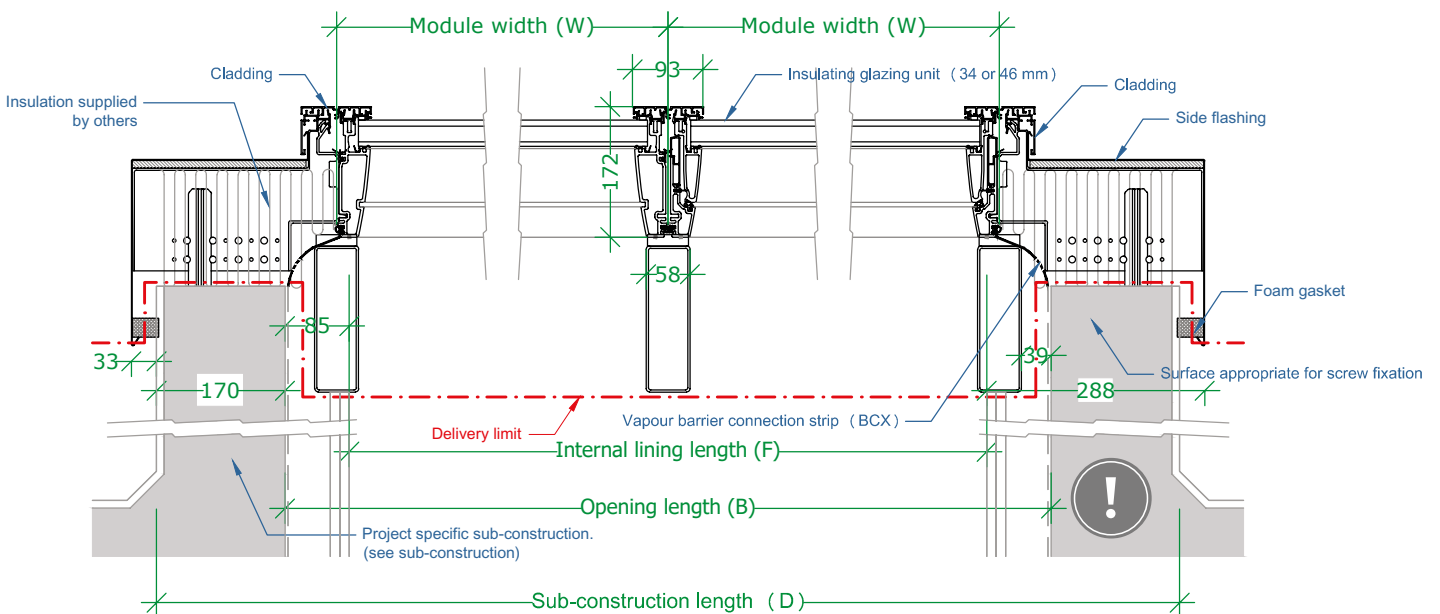
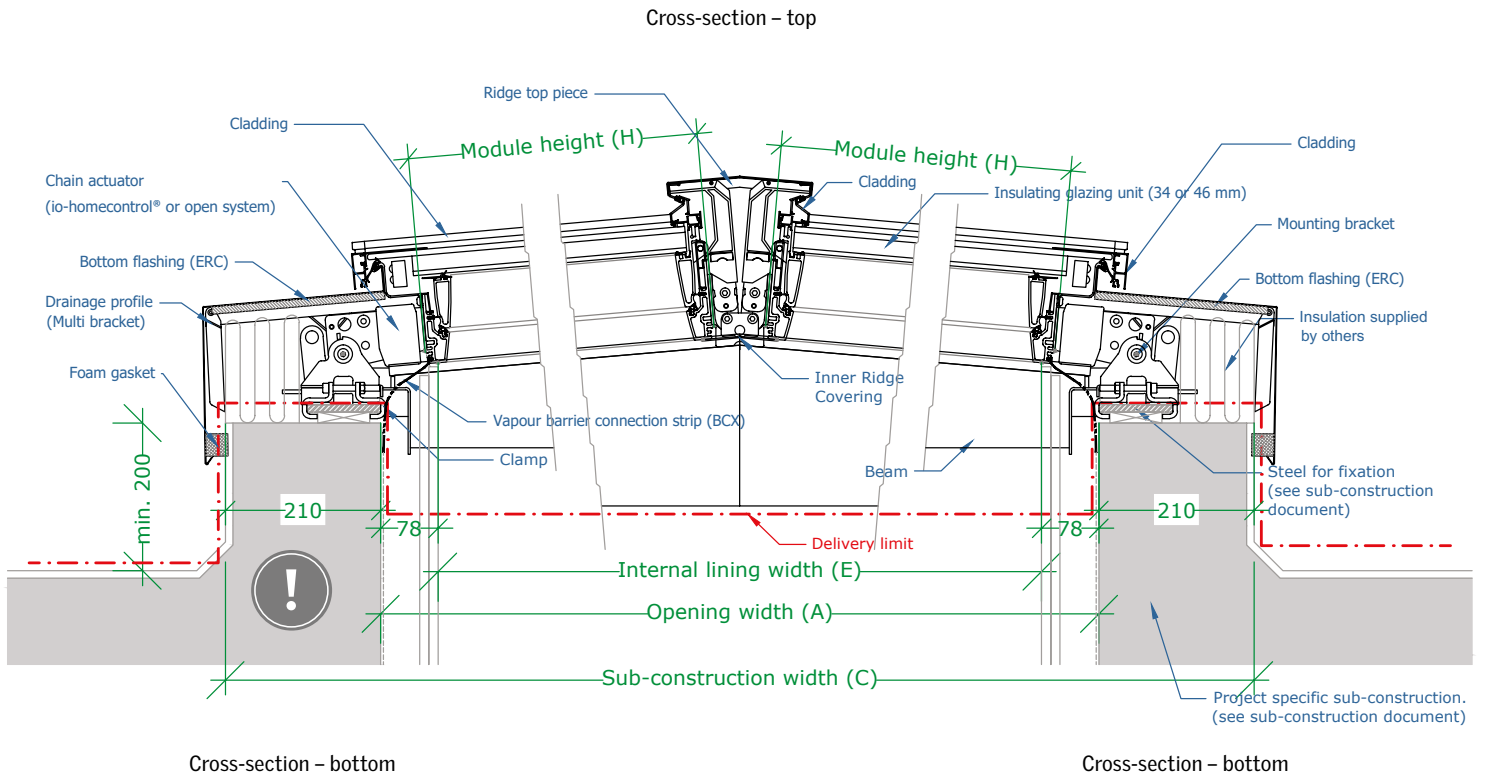

Longitudinal section

Please observe that a lateral slope on the modules is NOT possible, therefore top and bottom sub-construction must be horizontal.

# Ridgelight at 5° with Beams (Parallel beam with curved profile)

Ridgelights at 5° pitch guarantee the illusion of a small glass roof with discreet transverse parallel supporting beams. The prefabricated VELUX beam supports the skylights and creates

the 5° pitch. The beams are mounted on a standard steel profile, 100 mm wide (not a VELUX component), on top of the sub-construction.

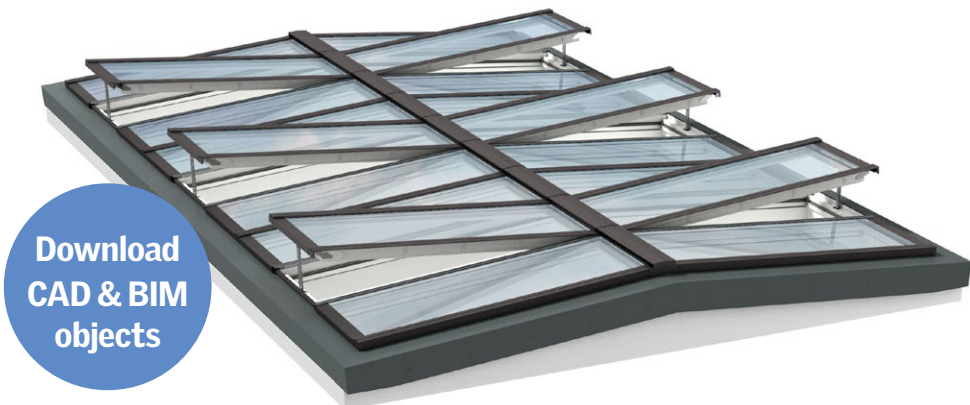

Download CAD & BIM objects

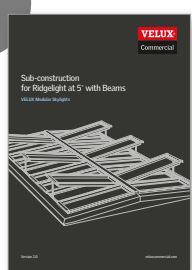

Sub-construction for Ridgelight at 5° with Beams at: [veluxcommercial.com](http://veluxcommercial.com)

Use the table to define module height (H) and/or installation pitch (α).

Example:  
A = 4975 mm

Result:  
α: H = 2400 mm at an installation pitch of 5°

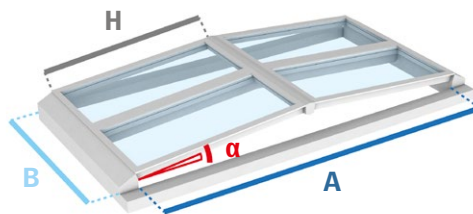

- H: Module height
- α: Installation pitch
- A: Opening width
- B: Opening length

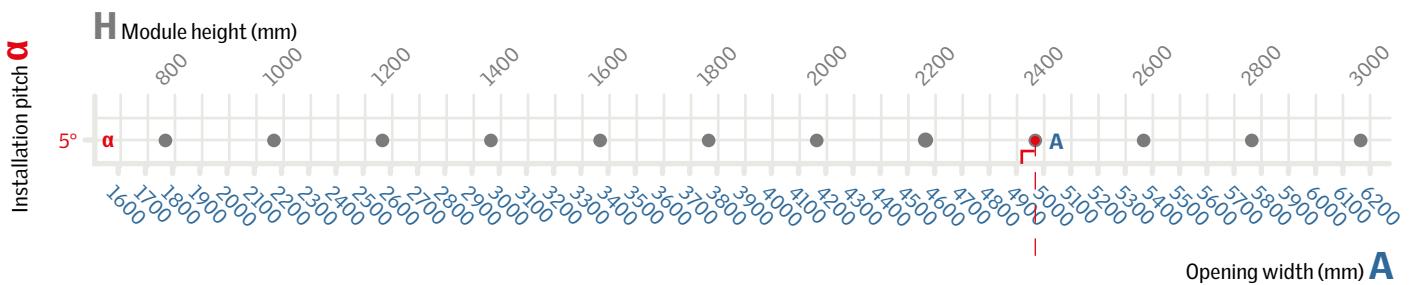

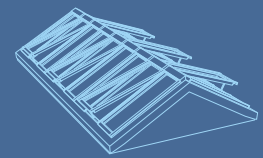

## Sectional drawings

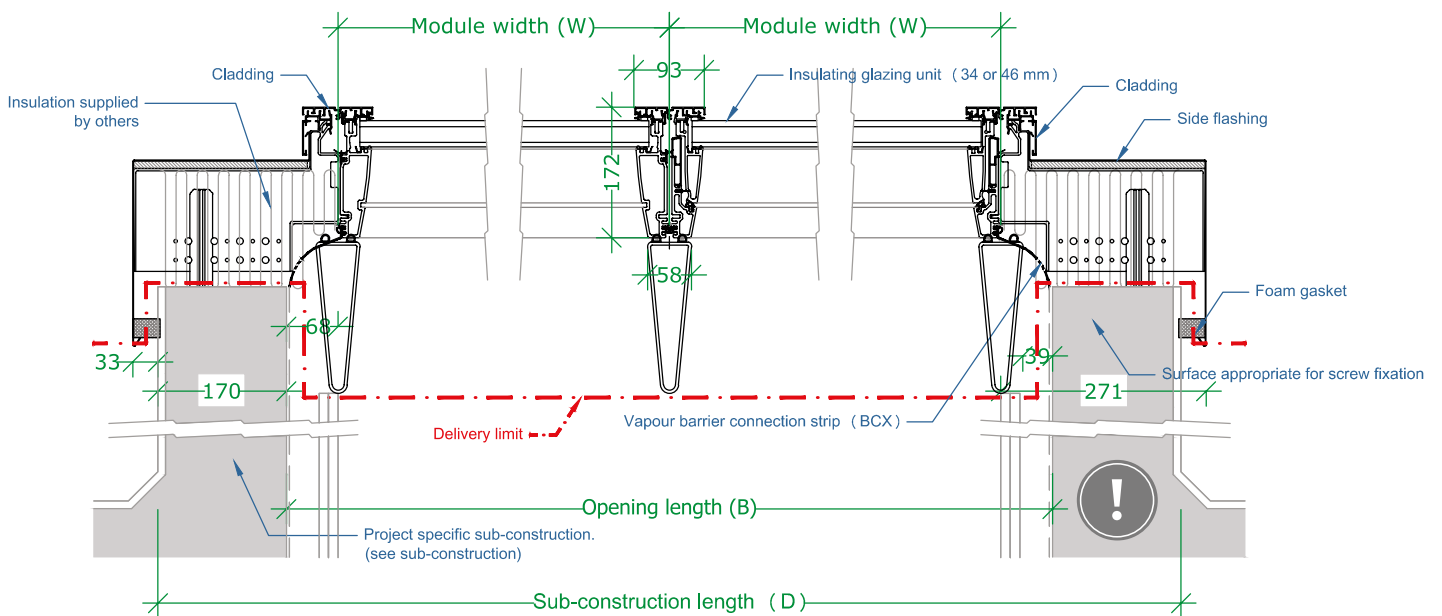
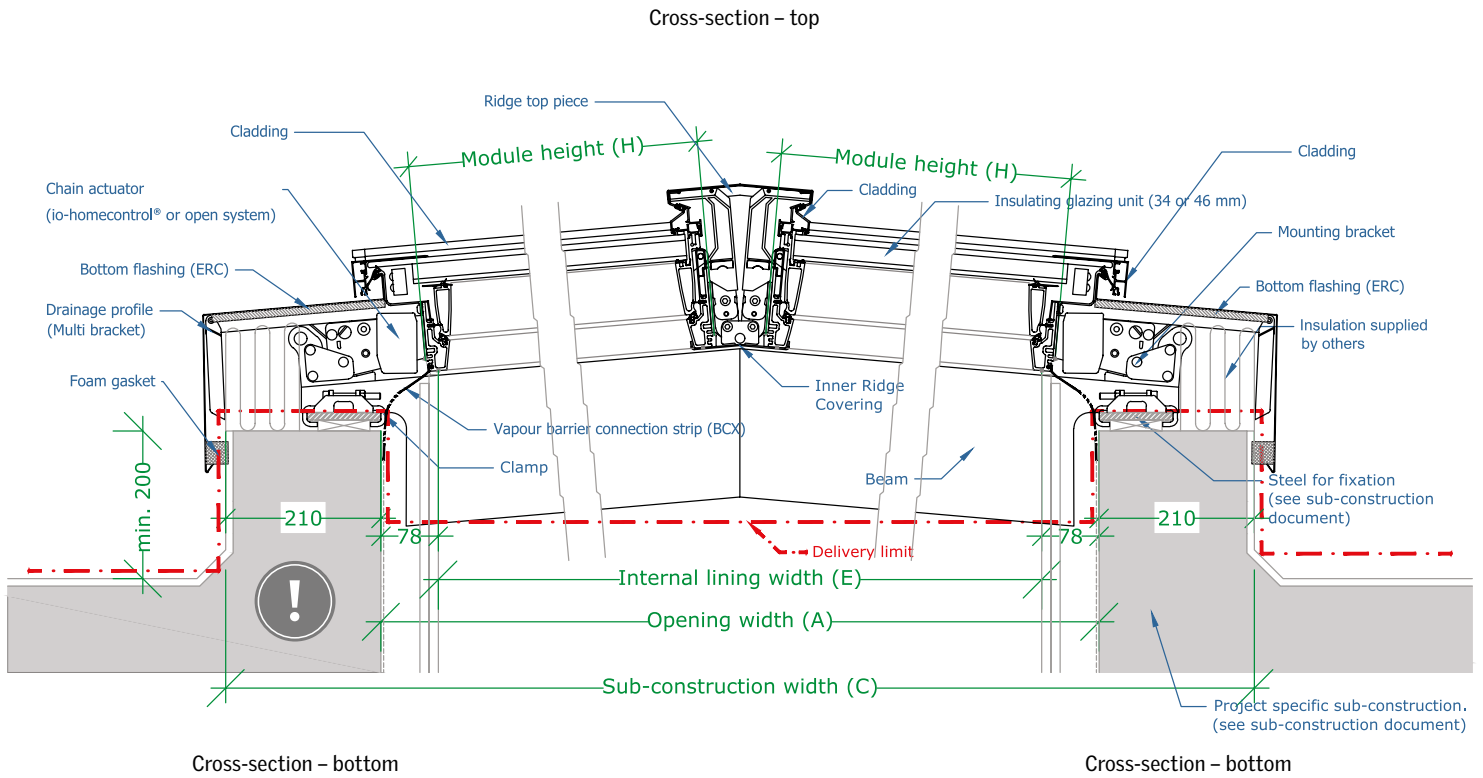

Please observe that a lateral slope on the modules is NOT possible, therefore top and bottom sub-construction must be horizontal.

# Step Longlight 5-25°

Longlights in a Step solution are multiple rows of VELUX Modular Skylights installed close to each other using joint brackets and a clamping system that guarantee a fast and secure installation. The prefabricated flashing allows for configurations with a pitch of 5 to 25°.

The Longlight Step solution is mounted on 100 mm wide standard steel profiles (not a VELUX component).

Please note that the same installation pitch is required on all rows and that the maximum distance from the top of the lowest row of the modules to the top of total skylight is 15 metres.

The supporting beams between the rows are not included in the VELUX delivery. The support structure must be designed by a structural engineer.

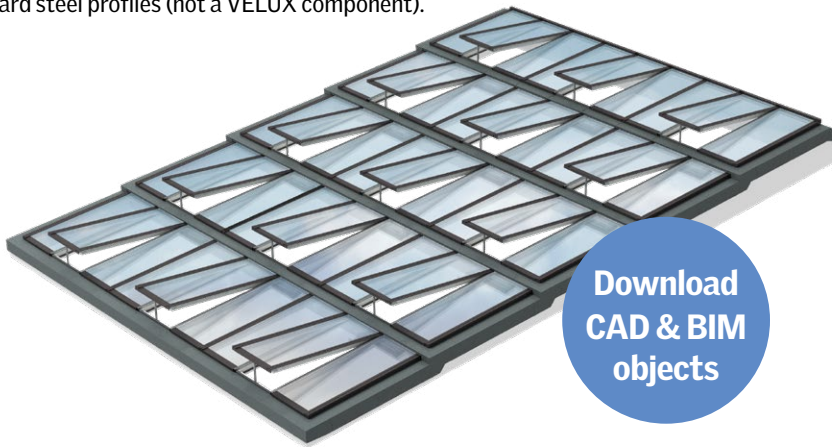

Download  
CAD & BIM  
objects

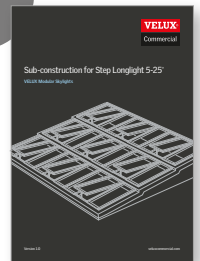

Sub-construction for  
Step Longlight 5-25° at:  
[veluxcommercial.com](http://veluxcommercial.com)

Use the table to define module height (H) and/or installation pitch (α).

Example:  
A = 7000 mm

Result:  
α1: H = 3 rows x 2200 mm at an installation pitch of 8.5°  
or  
α2: H = 3 rows x 2400 mm at an installation pitch of 23.5°

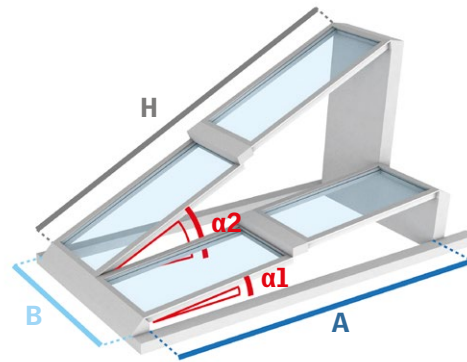

H: Module height  
α: Installation pitch  
A: Opening width  
B: Opening length

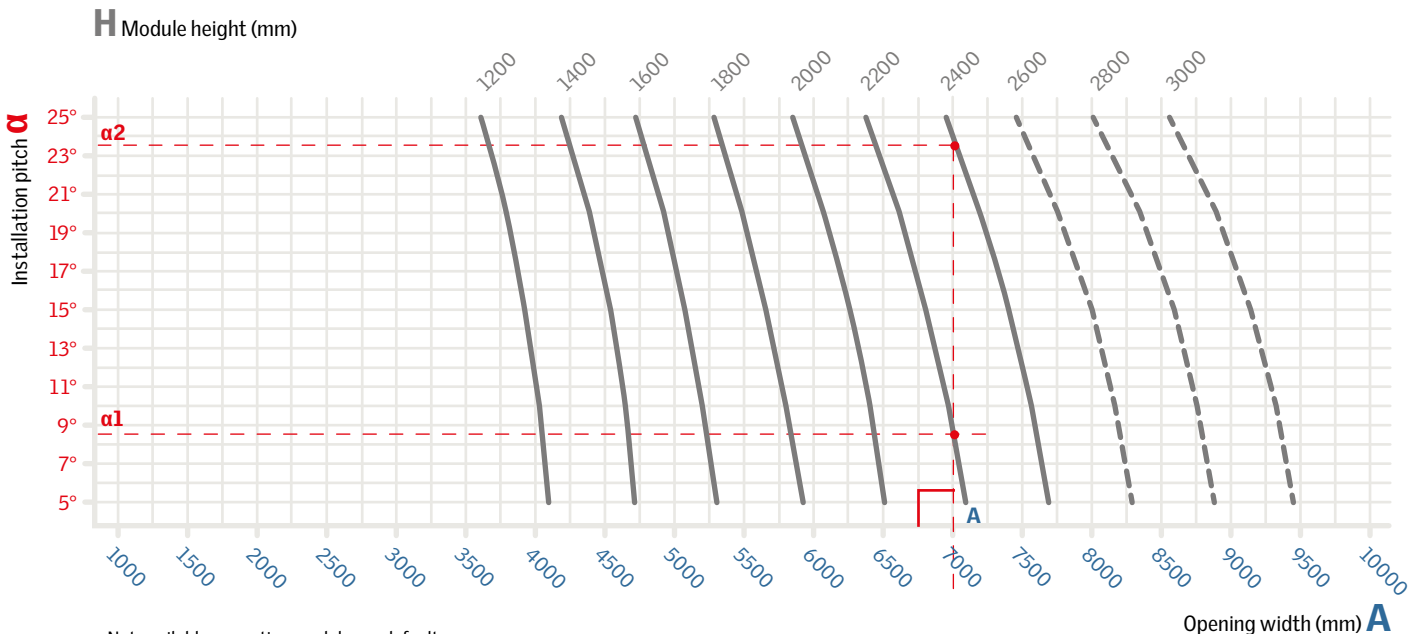

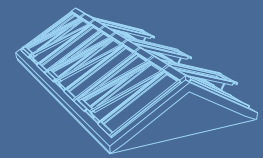

## Sectional drawings

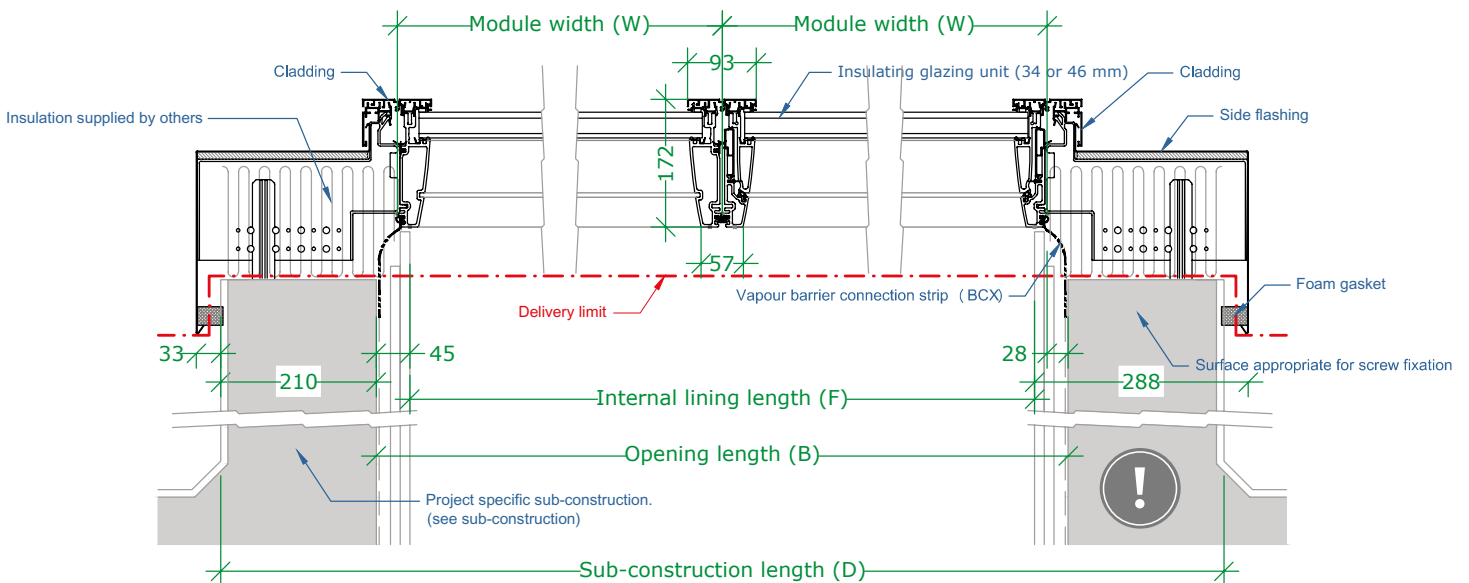
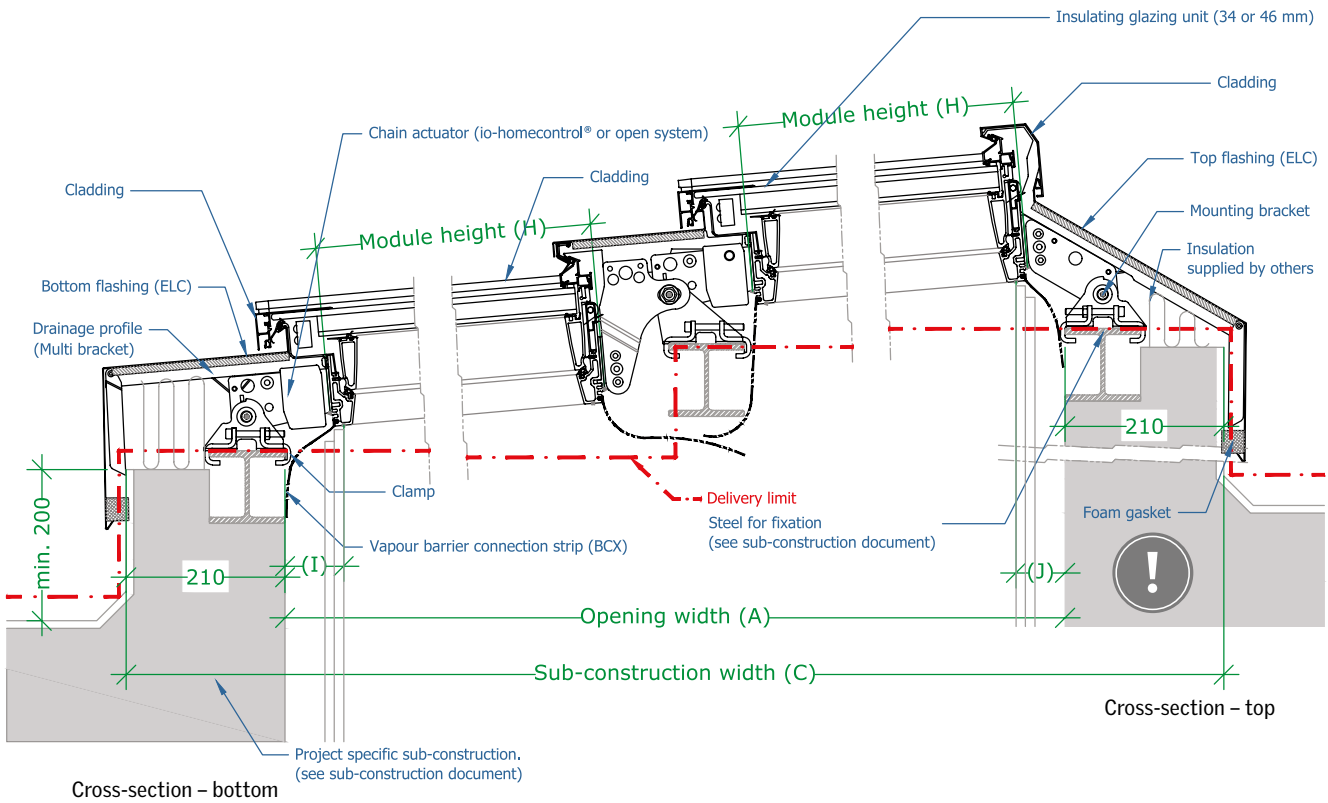

Please observe that a lateral slope on the modules is NOT possible, therefore top and bottom sub-construction must be horizontal.



## Step Wall-mounted Longlight 5-25°

A Step solution consisting of multiple rows of VELUX Modular Skylights installed as Step Wall-mounted Longlight, where the modules are installed against a vertical wall in the top. The rows are installed close to each other using joint brackets and a clamping system that guarantee a fast and secure installation. The prefabricated flashings allows for configurations with a pitch of 5 to 25°.

The Wall-mounted Longlight Step solution is mounted on 100 mm wide standard steel profiles (not a VELUX component).

Please note that the same installation pitch is required on all rows and the maximum distance from the top of the vertical wall to the top of the lowest row of modules is 15 metres.

The supporting beams between the rows are not included in the VELUX delivery. The support structure must be designed by a structural engineer.

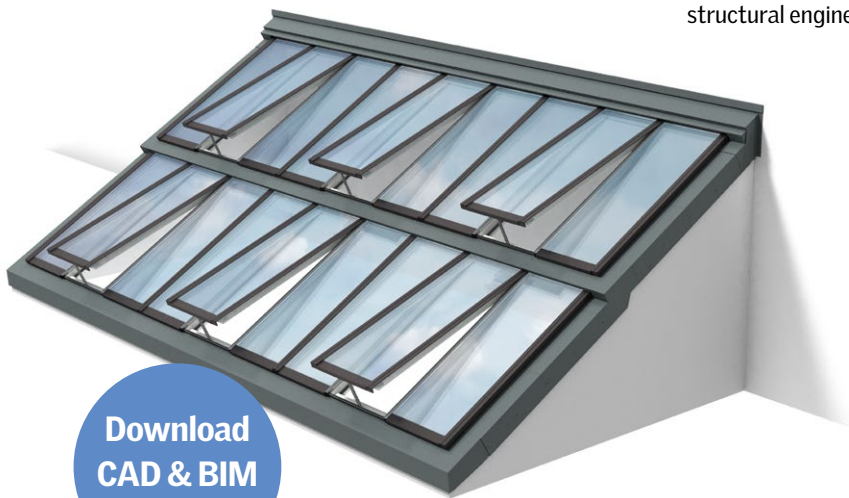

Download  
CAD & BIM  
objects

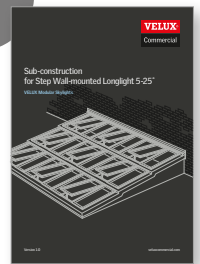

Sub-construction for  
Step Wall-mounted Longlight 5-25°  
[veluxcommercial.com](http://veluxcommercial.com)

## Design your own grand ideas – Create a magnificent skylight

Ready to know if your ideas can become a reality?

Let us calculate your possibilities and give a price estimate for your chosen solution.

Contact your VELUX sales office for more details.



Sub-construction quality assurance (QA) document and specification document.

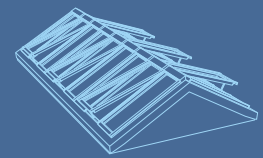

## Sectional drawings

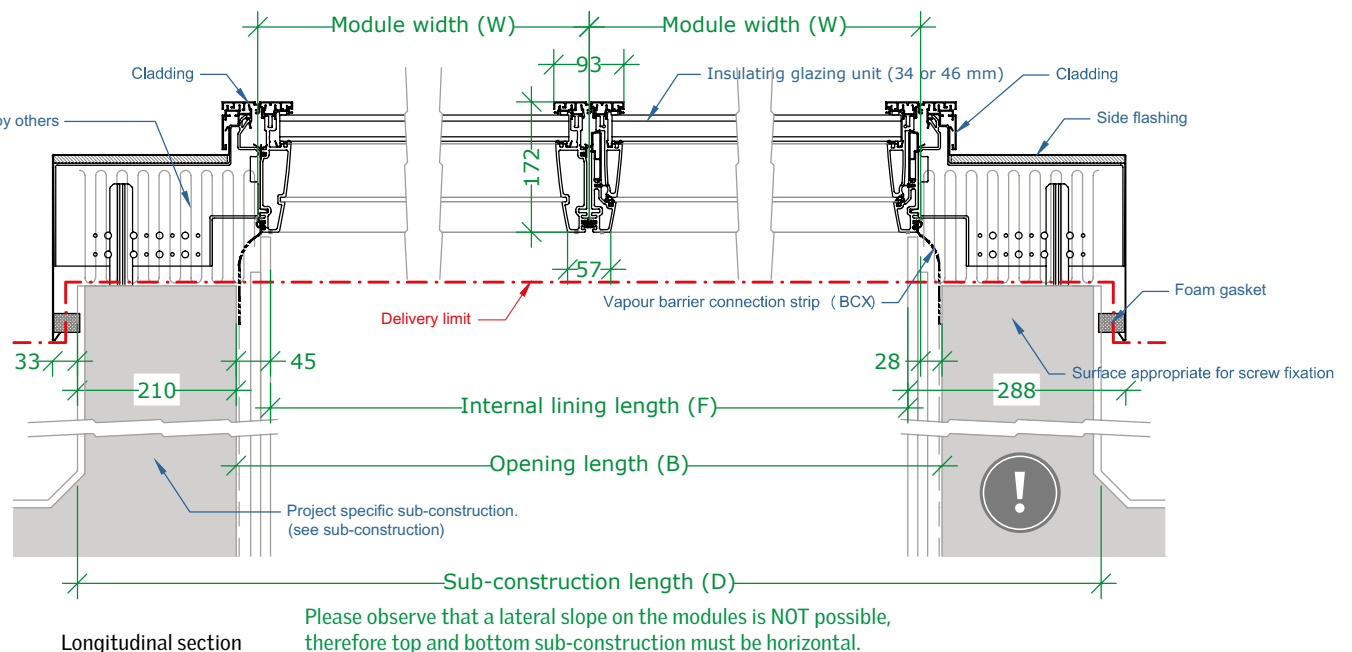
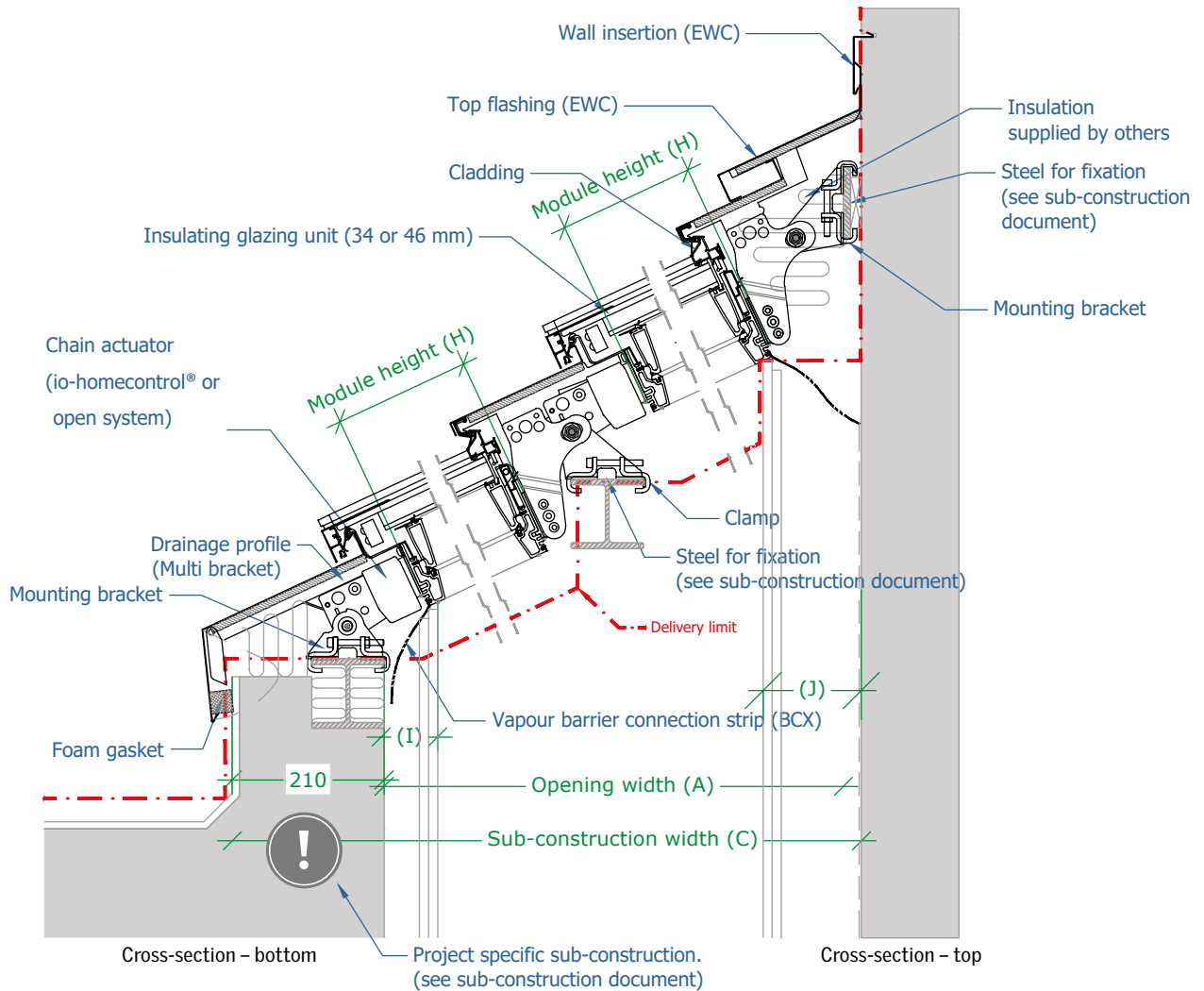

Please observe that a lateral slope on the modules is NOT possible, therefore top and bottom sub-construction must be horizontal.

## Step Ridgelight 25°

A Step Ridgelight 25° consist of a Ridgelight with one or more rows of modules below, on one or both sides, mounted close to each other using joint brackets and a clamping system that guarantee a fast and secure installation. The prefabricated flashing allows for configurations with a pitch of 25°

The Ridgelight Step solution is mounted on 100 mm wide standard steel profiles (not a VELUX component).

Please note that the same installation pitch is required on all rows and that the maximum distance from the top of the lowest row of the modules to the top of total skylight is 15 metres.

The supporting beams between the rows are not included in the VELUX delivery. The support structure must be designed by a structural engineer.

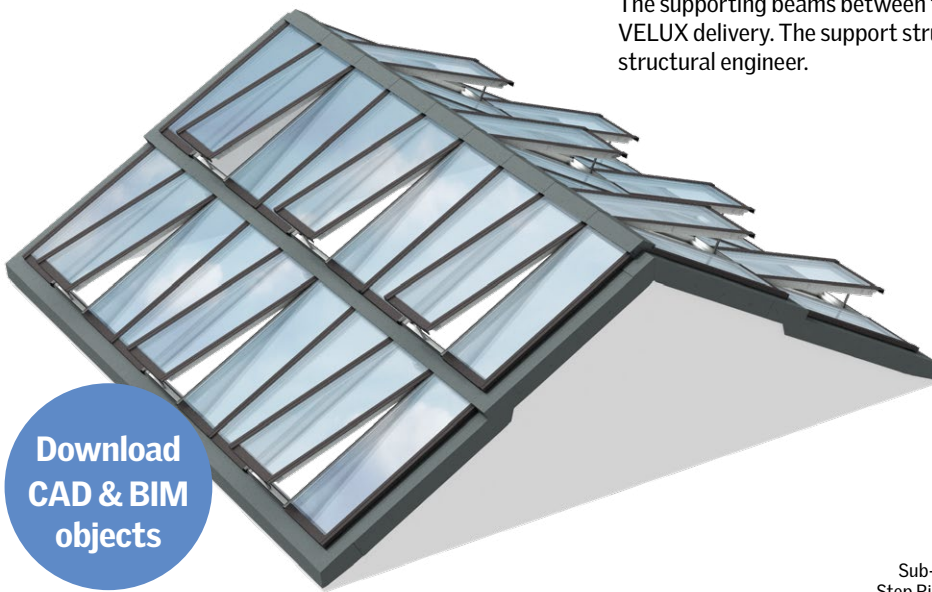

Download  
CAD & BIM  
objects



Sub-construction for  
Step Ridgelight at 5° at:  
[veluxcommercial.com](http://veluxcommercial.com)

## Design your own grand ideas – Create a magnificent skylight

Ready to know if your ideas can become a reality?

Let us calculate your possibilities and give a price estimate for your chosen solution.

Contact your VELUX sales office for more details.

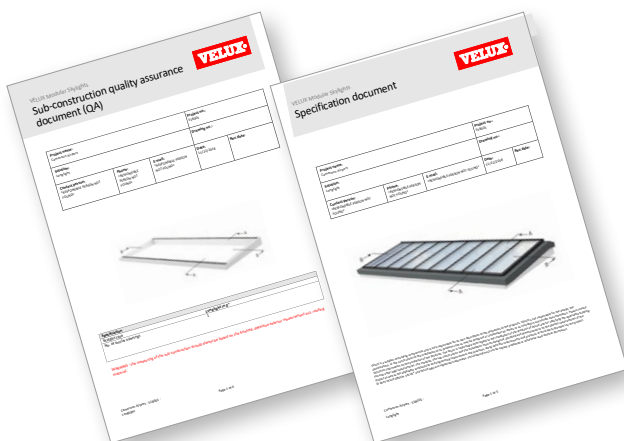

Sub-construction quality assurance (QA) document and specification document.

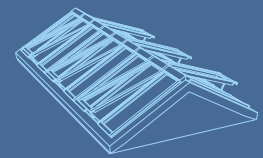

## Sectional drawings

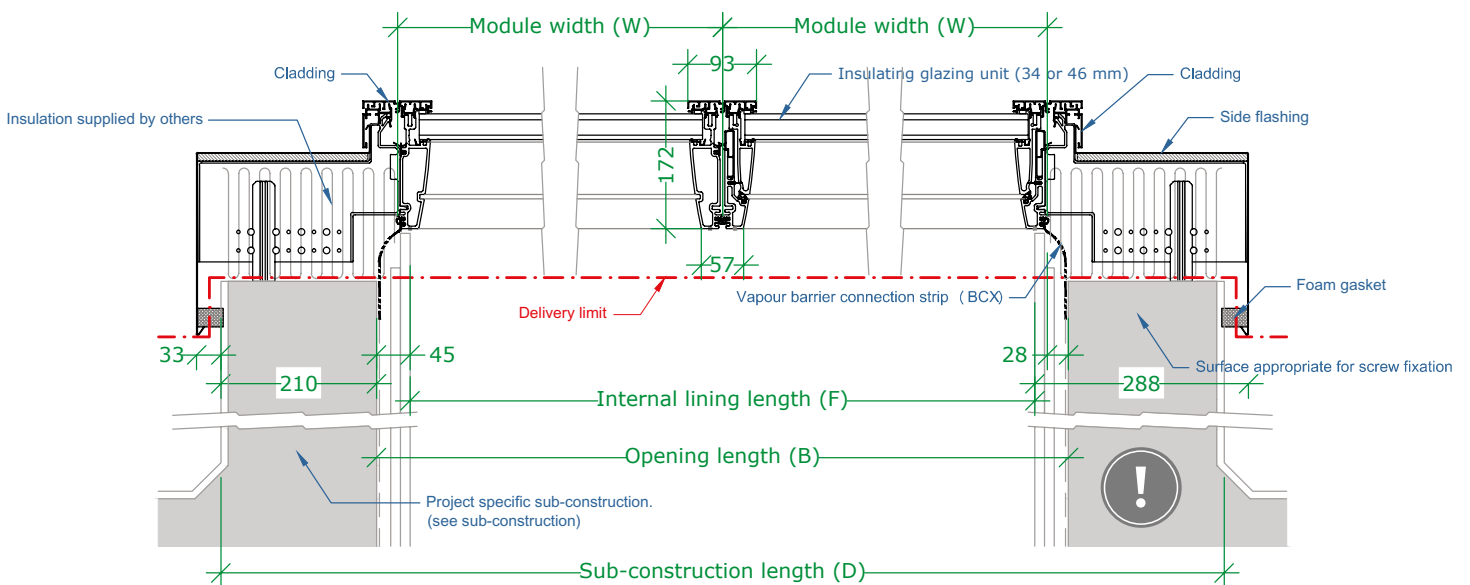
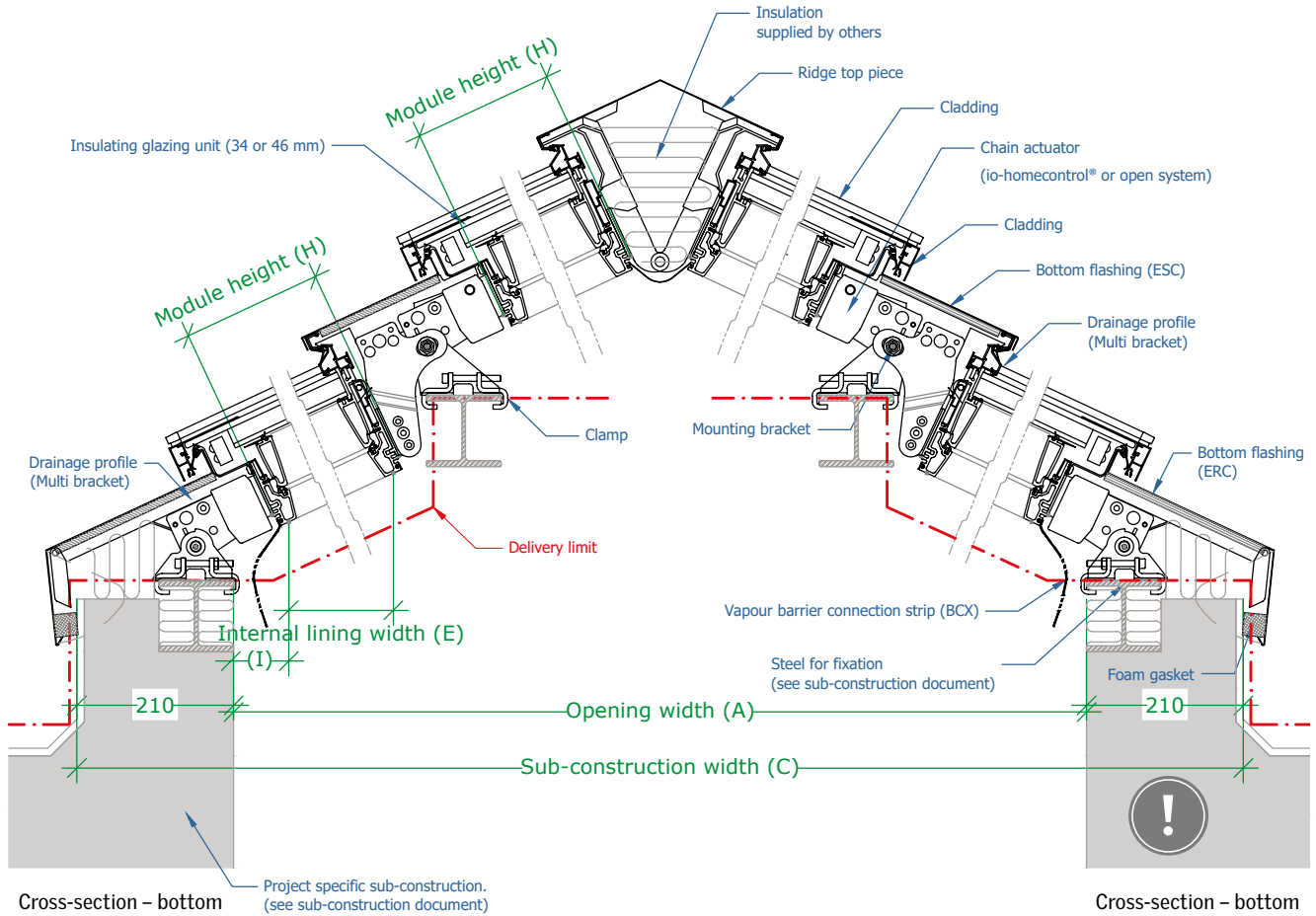

Longitudinal section

Please observe that a lateral slope on the modules is NOT possible, therefore top and bottom sub-construction must be horizontal.

## Step Ridgelight 5-25° on Girder

A Step Ridgelight 5-25° on Girder, consist of a Ridgelight with one or more rows of modules below, on one or both sides, mounted close to each other using joint brackets and a clamping system that guarantee a fast and secure installation. The prefabricated flashing allows for configurations with a pitch of 5° or 25°.

The Step Ridgelight 5-25° on Girder solutions are mounted on 100 mm wide standard steel profiles (not a VELUX component).

Please note that the same installation pitch is required on all rows on the same side, however different installation pitches is possible on each side of the girder.

The maximum distance from the top of the lowest row of the modules to the top of total skylight is 15 metres.

The supporting beams between the rows are not included in the VELUX delivery. The support structure must be designed by a structural engineer.

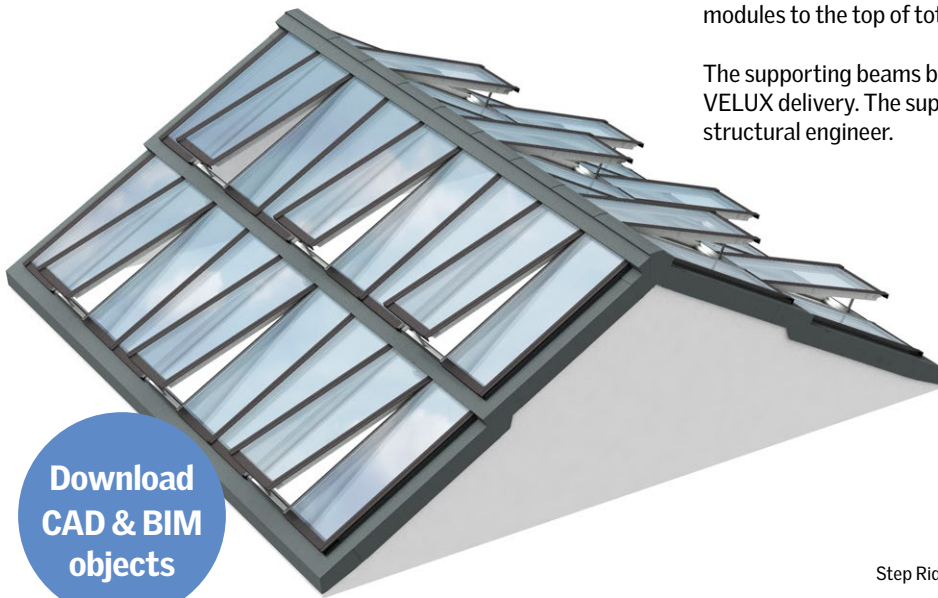

Download  
CAD & BIM  
objects



Sub-construction for  
Step Ridgelight 5-25° on Girder at:  
[veluxcommercial.com](http://veluxcommercial.com)

## Design your own grand ideas – Create a magnificent skylight

Ready to know if your ideas can become a reality?  
Let us calculate your possibilities and give a price estimate for your chosen solution.  
Contact your VELUX sales office for more details.



Sub-construction quality assurance (QA) document and specification document.



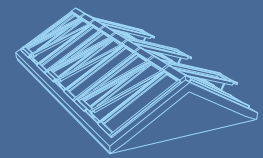

## Sectional drawings

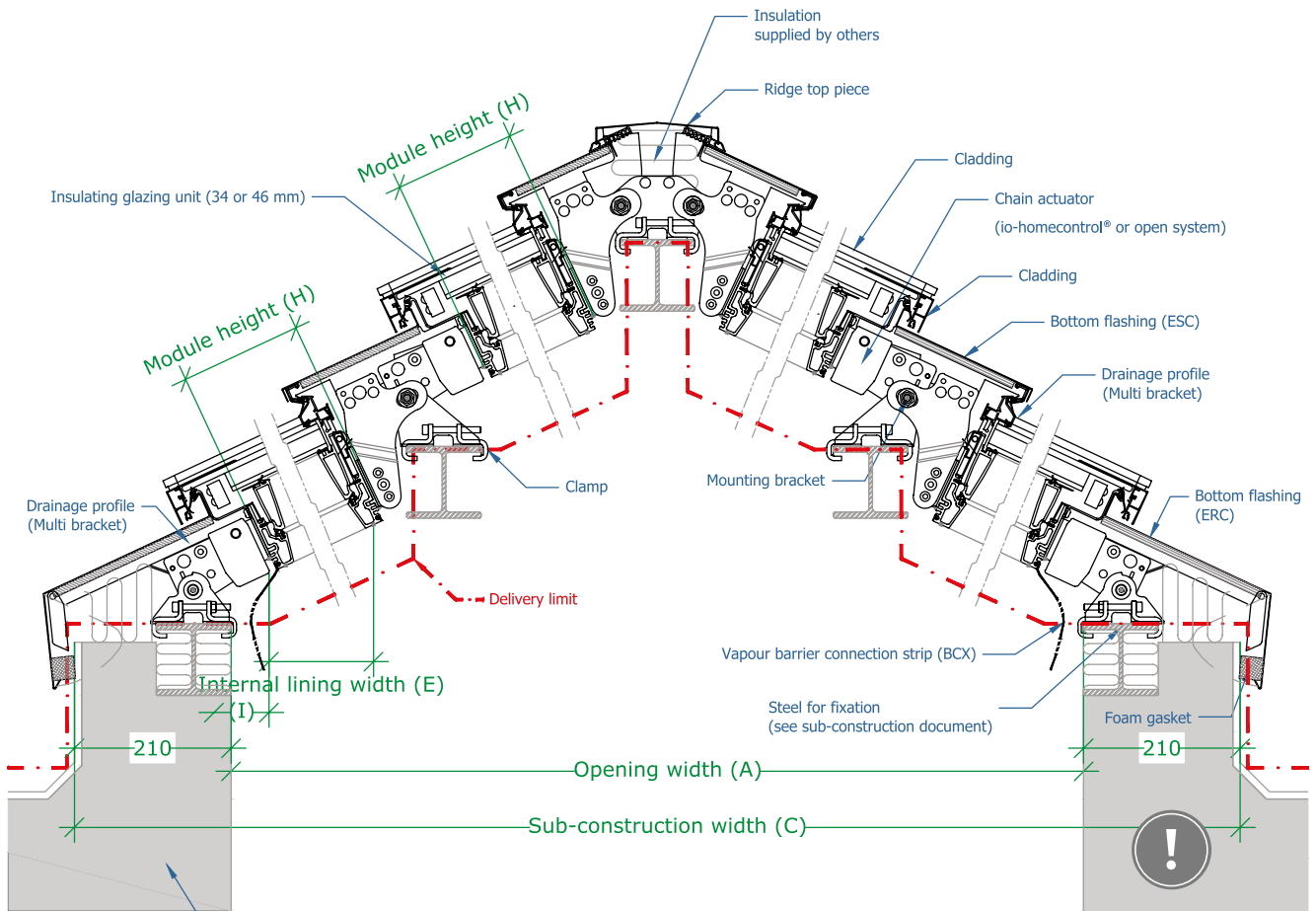

Cross-section - bottom

Cross-section - bottom

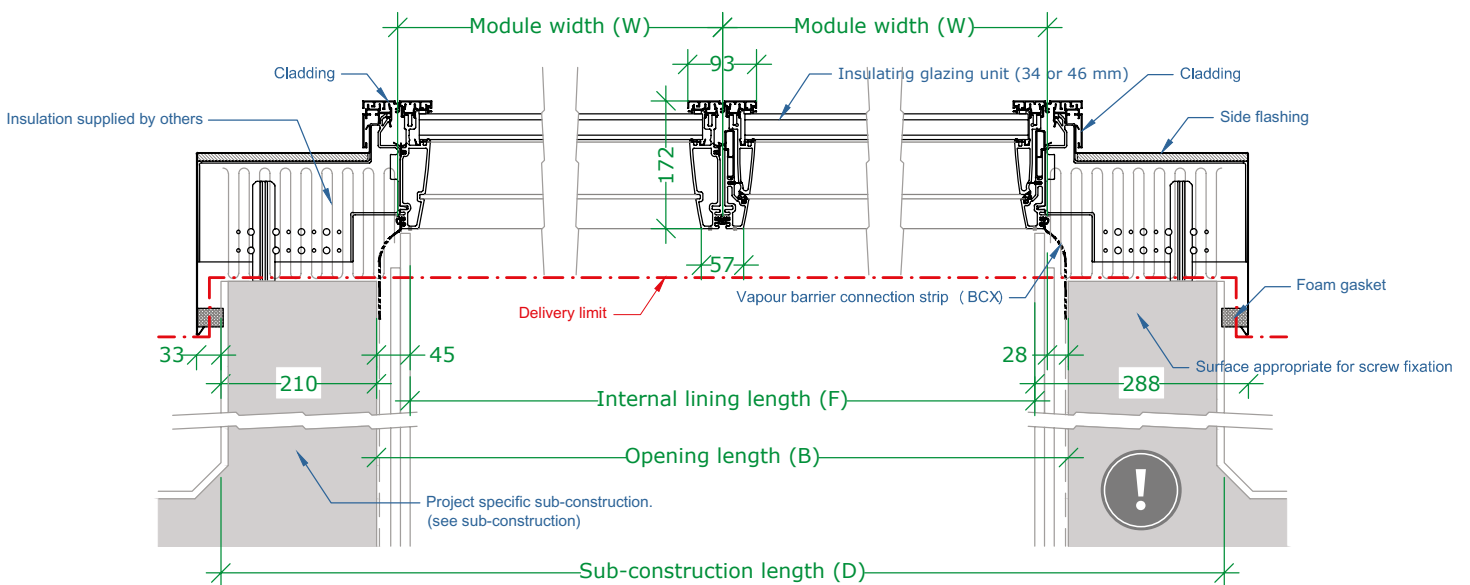

Longitudinal section

Please observe that a lateral slope on the modules is NOT possible, therefore top and bottom sub-construction must be horizontal.

# Atrium Longlight

An Atrium solution consists of several Longlights attached to each other in the sub-construction. A drainage gutter separates each assembly.

The supporting beams are not included in the VELUX delivery. The support structure is part of the primary structure of the building and will have to be designed by a structural engineer.

The distance between the skylights depends on thickness of insulation, width of drainage gutter and pitch of skylights. The shown example of an Atrium is designed with 100 mm insulation and a 400 mm wide drainage gutter in a 5° pitch, resulting in a distance between skylights of 820 mm.



Download  
CAD & BIM  
objects

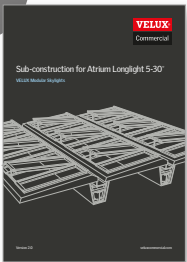

Sub-construction  
for Atrium Longlight at:  
[veluxcommercial.com](http://veluxcommercial.com)

Use the table to define module height (H) and/or installation pitch (α).

Example:  
A = 2870 mm

Result:  
α1: H = 2800 mm at an installation pitch of 10°  
or  
α2: H = 3000 mm at an installation pitch of 23°

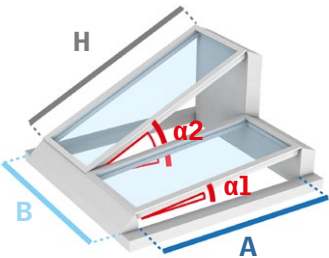

H: Module height  
α: Installation pitch  
A: Opening width  
B: Opening length

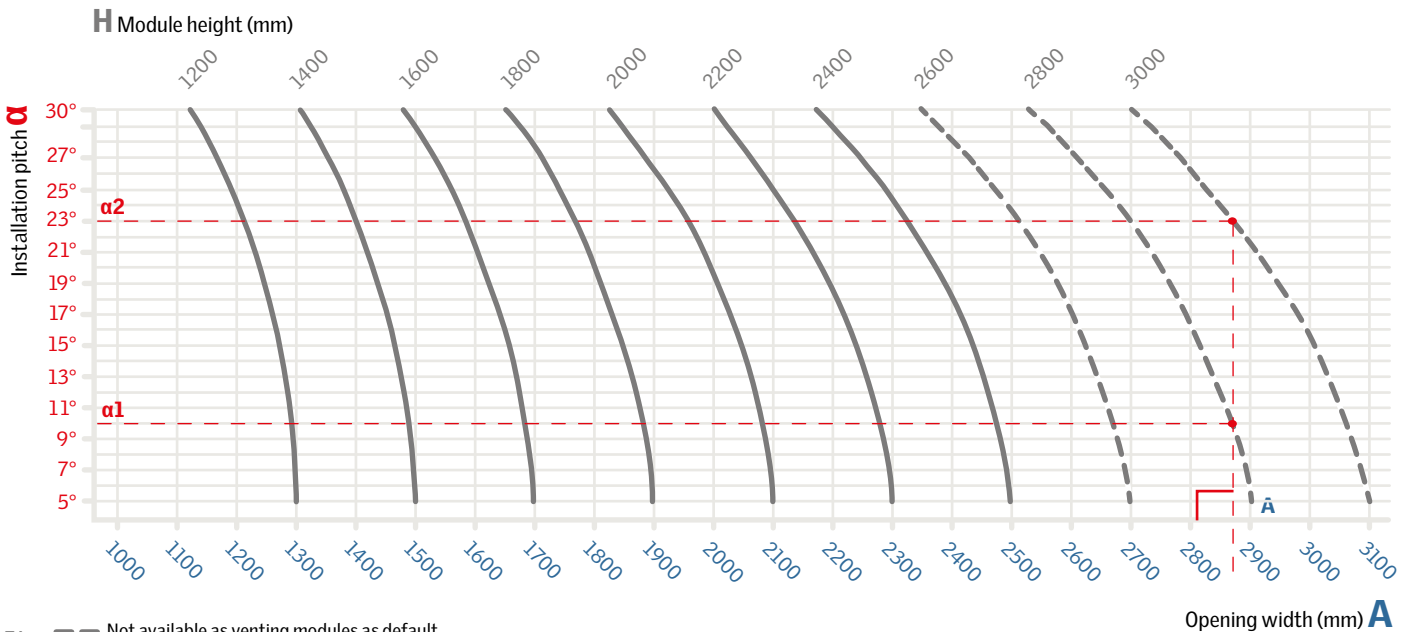

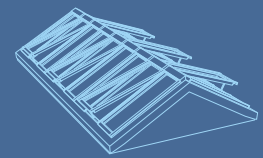

## Sectional drawings

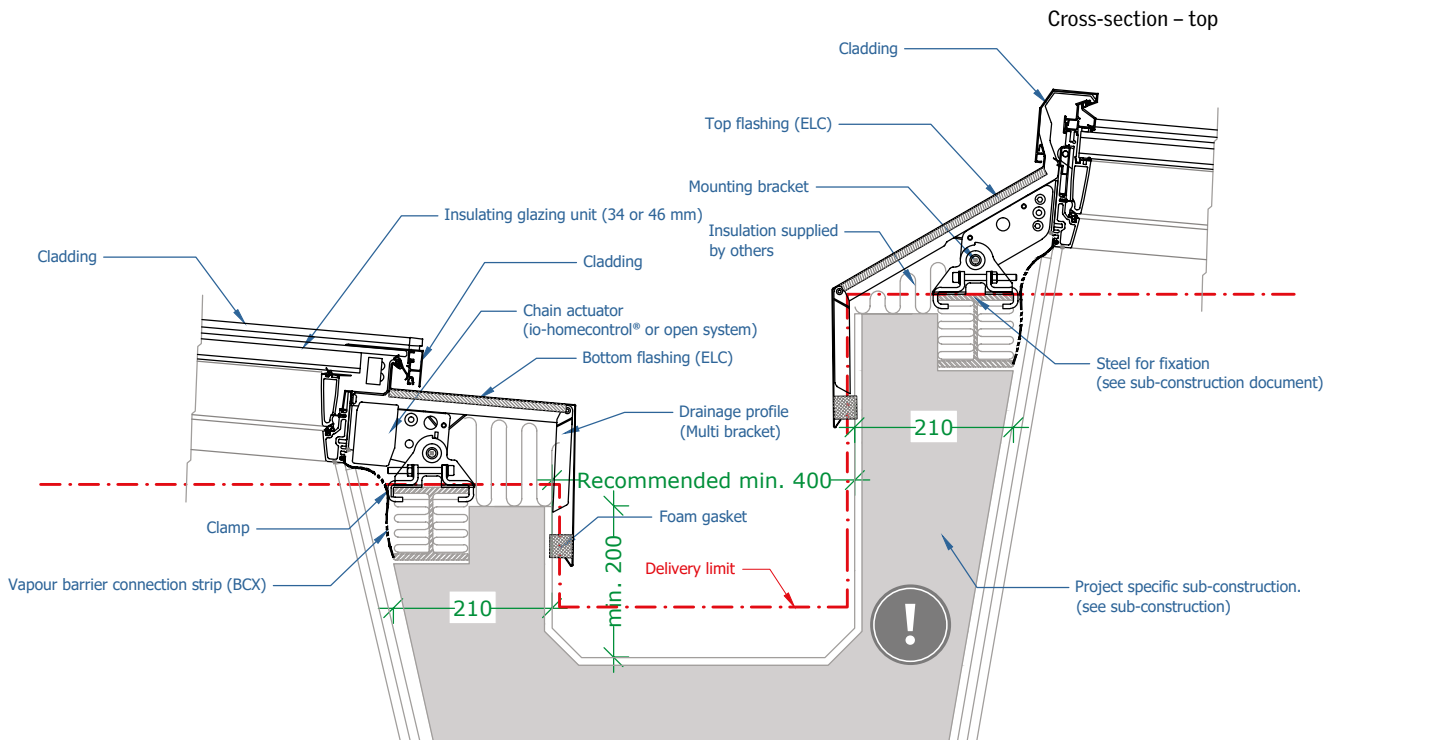

Cross-section - bottom

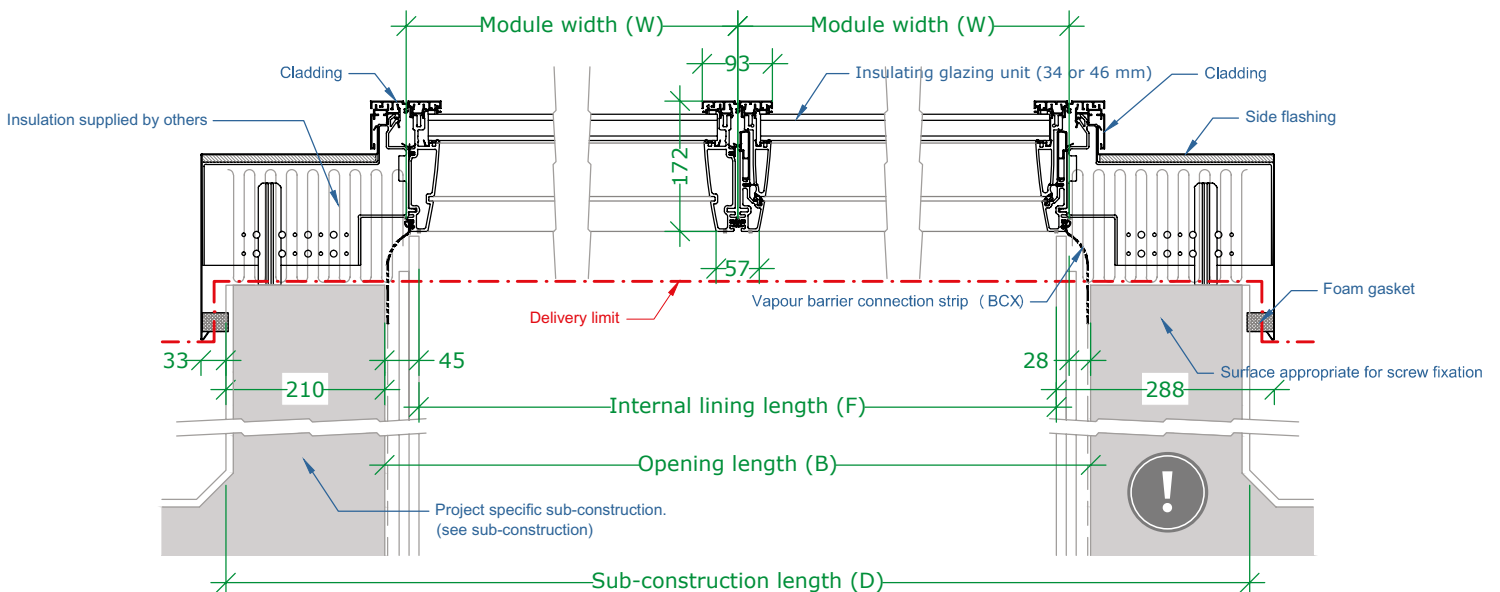

Longitudinal section

Please observe that a lateral slope on the modules is NOT possible, therefore top and bottom sub-construction must be horizontal.

# Atrium Ridgelight & Atrium Ridgelight at 5° with Beams

An Atrium Ridgelight solution consists of several Ridgelights attached to each other in the sub-construction. A drainage gutter separates each strip.

The supporting steel beams are not included in the VELUX delivery. The support structure is part of the primary structure of a building and must be designed by a structural engineer.

The distance between the skylights depends on thickness of insulation, width of drainage gutter and pitch of skylights. The shown example of an Atrium is designed with 100 mm insulation and a 400 mm wide drainage gutter in a 5° pitch, resulting in a distance between the skylights of 820 mm.

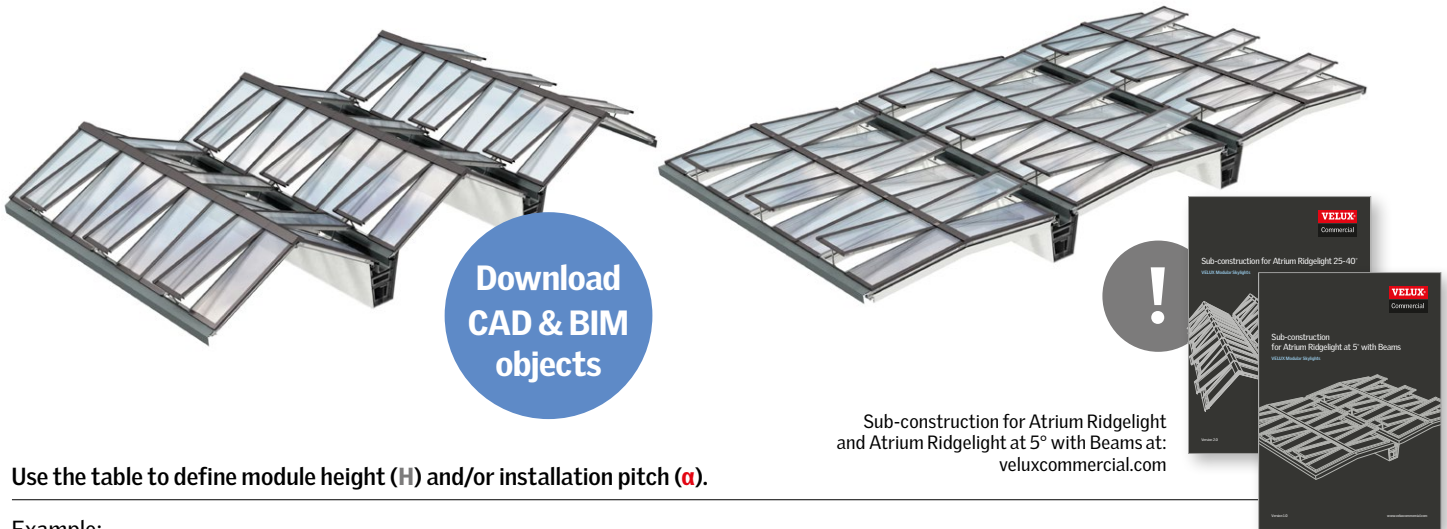

Use the table to define module height (H) and/or installation pitch ( $\alpha$ ).

Example:  
 $A = 3775 \text{ mm}$

Result:  
 $\alpha 1$ :  $H = 1800 \text{ mm}$  at an installation pitch of  $5^\circ$   
 $\alpha 2$ :  $H = 2000 \text{ mm}$  at an installation pitch of  $26^\circ$   
 or  
 $\alpha 3$ :  $H = 2200 \text{ mm}$  at an installation pitch of  $35.5^\circ$

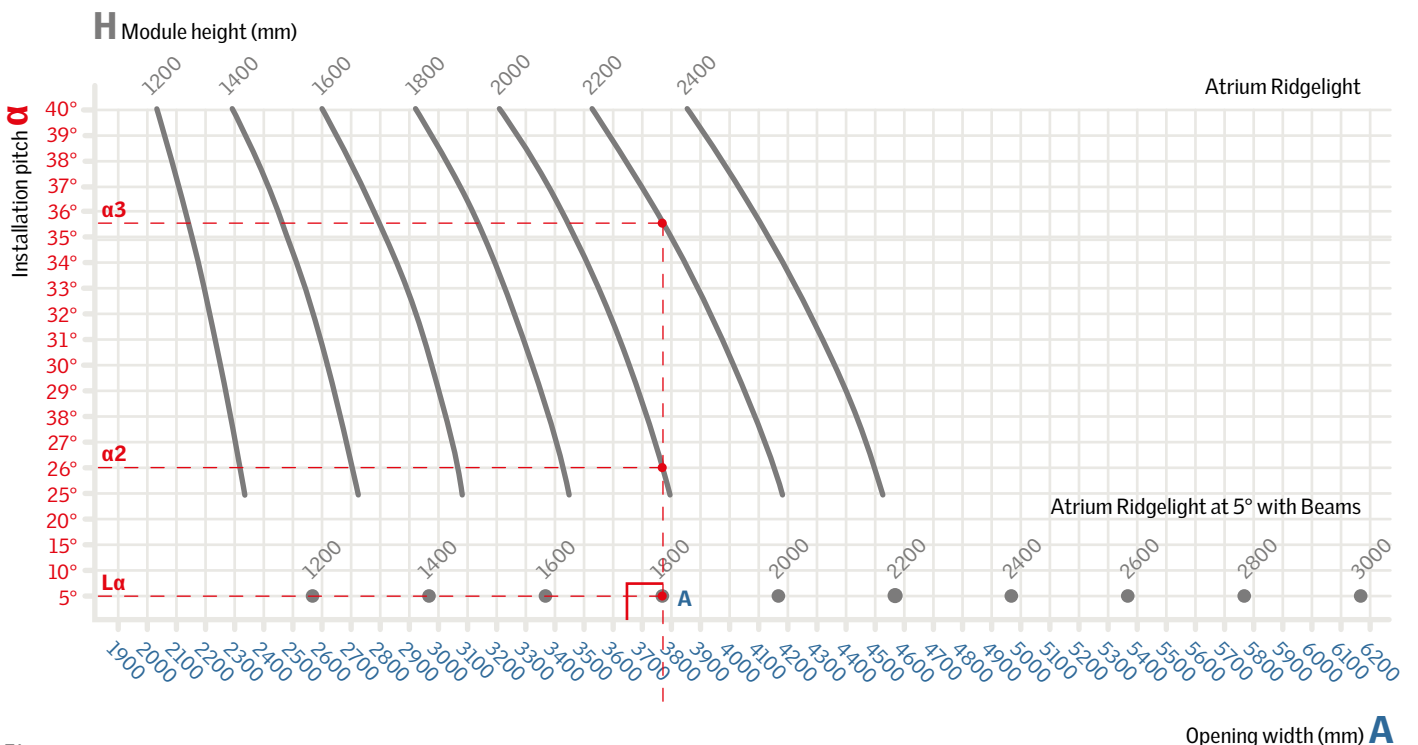

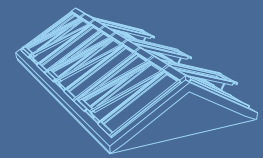

## Sectional drawings

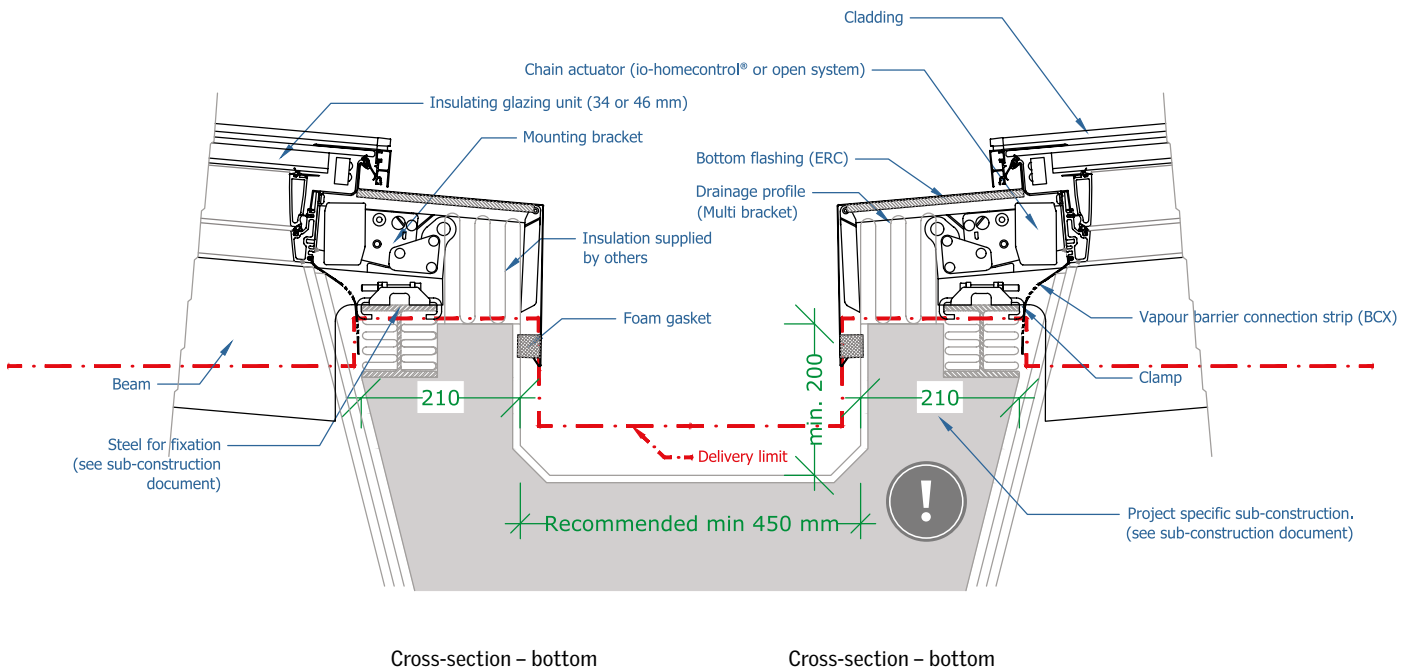
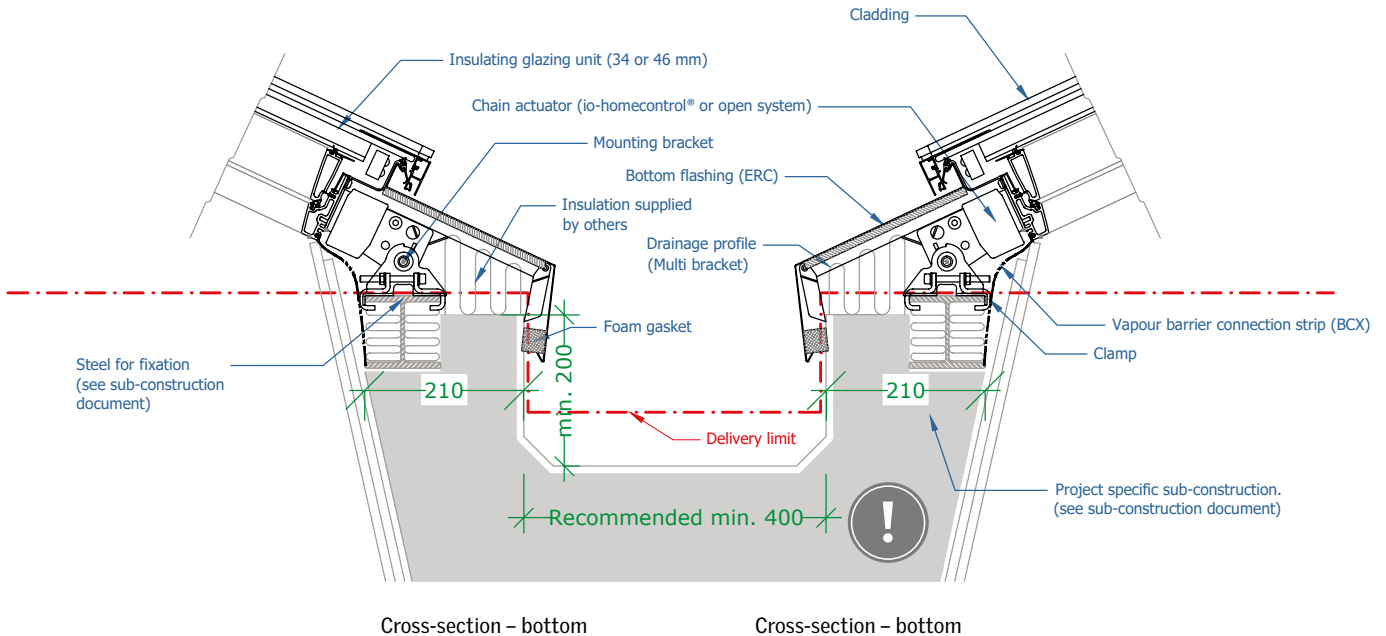

Please observe that a lateral slope on the modules is NOT possible, therefore top and bottom sub-construction must be horizontal.

\* For longitudinal section drawings for Atrium Ridgelight and Atrium Ridgelight 5°, see pages 61, 63 and 65.





**Class 1**

15

12.5

10

**Class 2**

6.75

**Product Data**

5.0

**Class 3**

2.5

2.2

2.0

## Skylight module



### Essential characteristic performances for CE-marked skylight modules (EN 14351-1)

H-C -----	
Essential characteristics	Performance
Resistance to wind load	Class C5 <sup>1)</sup>
Resistance to snow load	See glazing variant construction
Reaction to Fire*	Class B, s1-d0 - B, s1-d2 **
External fire performance***	B <sub>ROOF</sub> (t1) ; B <sub>ROOF</sub> (t4)
Watertightness****	E1200
Impact resistance	NPD
Load-bearing capacity of safety devices	NPD <sup>2)</sup>
Acoustic performance	35 (-1; -5) - 38 (-1; -4) dB <sup>3)</sup>
Thermal transmittance	Double glazing 1.3-1.5 W/m <sup>2</sup> K <sup>3)</sup> Triple glazing: 0.86-1.1 W/m <sup>2</sup> K <sup>3)</sup>
Solar factor	0.61 - 0.14 <sup>3)</sup>
Light transmittance	0.80 - 0.16 <sup>3)</sup>
Air permeability*****	Class 4

<sup>1)</sup> For sizes up to 2400 mm height, except HVC 090220, HVC 090240, HVC 100220 and HVC 100240 with glazing variants 10L and 11L, which have Class C4. For skylight height > 2400 mm: NPD.

<sup>2)</sup> No safety device on VELUX Modular Skylights

<sup>3)</sup> For specific types and sizes, see the table with glazing variants on page 100

#### Note:

The performances in the above table and the attached notes to these are valid for the size grid shown on page 9.

For sizes outside the size grid, altering performances may apply. The changes in performances depend on the actual size and are therefore to be identified individually.

\* For explanation of test method and results, please refer to section on Reaction to Fire

\*\* Variants with inner pane of 55.2 lamination have a sub-class s1,d0

Variants with inner pane of 33.2 and 44.2 lamination have a sub-class s1,d2

\*\*\* For explanation of test method and results, please refer to section on External fire performance

\*\*\*\* For explanation of test method and results, please refer to section on Watertightness

\*\*\*\*\* For explanation of test method and results, please refer to section on Air Permeability

### Performance of fire resistant skylight modules (EN 13501-2 + A1)

HFS -----	
Essential characteristics	Performance
Resistance to Fire HFS (fixed)	REI30

#### Note:

The fixed fire resistant modules HFS are tested in accordance with EN 1365-2. The classifications are expressed in accordance with EN 13501-2 + A1. The tests are carried out without roller blinds by default. If a customer wishes to install roller blinds on the fire resistant modules subsequently, the VELUX Group recommends that the customer obtains written approval from the local fire authorities. HFS has an intumescent seal strip between the fire resistant glazing and frame and between the modules. The strip expands when exposed to heat in order to contain the fire for a longer time. For more information on the performance characteristics of fire resistant skylight modules, see pages 100 and 117.

- When installing the fixed fire resistant modules HFS, the special HFS installation instructions regarding sealant and protection of the lining / bracket area must be followed. The obtained REI 30 classification of HFS is only valid if the instructions are strictly followed.
- It is the responsibility of the customer that the sub-construction meets the required fire resistance performance of the roof.
- When installing the fixed fire resistant modules HFS in combination with a Step solution, it is the responsibility of the user that the supporting structures between module lines are also designed to meet the fire resistance requirements of the roof construction, therefore not causing weak chain in the performance of the HFS module applications.



# Skylight module



## Opening under load

Glazing unit construction with a total glass thickness of 12 mm																	
Product ID		HVC 067---			HVC 075---			HVC 080---			HVC 090---			HVC 100---			
Height	Size [mm]	Width	675			750			800			900			1000		
	Motor program	Chain stroke [mm]	Electric current requirement [AMP]	Snow Load [Pa]	Chain stroke [mm]	Electric current requirement [AMP]	Snow Load [Pa]	Chain stroke [mm]	Electric current requirement [AMP]	Snow Load [Pa]	Chain stroke [mm]	Electric current requirement [AMP]	Snow Load [Pa]	Chain stroke [mm]	Electric current requirement [AMP]	Snow Load [Pa]	
HVC ---080	800	N0800	353	2.5	2023	353	2.5	1808	353	2.5	1685	353	2.5	1476	353	2.5	1305
		N1000		3.0	2643		3.0	2373		3.0	2218		3.0	1955		3.0	1740
		N1100		3.0	2952		3.0	2655		3.0	2484		3.0	2194		3.0	1958
		N1200		3.0	3262		3.0	2937		3.0	2751		3.0	2434		3.0	2175
		N1300		3.0	3572		3.0	3219		3.0	3017		3.0	2674		3.0	2393
HVC ---100	1000	N0800	410	2.5	1573	410	2.5	1400	439	2.5	1300	439	2.5	1132	439	2.5	994
		N1000		3.0	2073		3.0	1856		3.0	1731		3.0	1519		3.0	1346
		N1100		3.0	2323		3.5	2084		3.5	1946		3.5	1712		3.5	1521
		N1200		3.0	2574		3.5	2311		3.5	2161		3.5	1906		3.5	1697
		N1300		4.0	2824		3.5	2539		3.5	2376		3.5	2099		3.5	1873
HVC ---120	1200	N0800	410	2.5	1268	410	3.0	1123	526	3.0	1040	526	3.0	899	526	3.0	783
		N1000		3.0	1687		3.0	1505		3.5	1401		3.5	1223		3.5	1078
		N1100		3.0	1897		3.5	1696		3.5	1581		3.5	1386		3.5	1226
		N1200		3.0	2107		3.5	1888		4.0	1762		4.0	1548		4.0	1373
		N1300		4.0	2317		4.0	2079		4.0	1942		4.0	1710		4.0	1521
HVC ---140	1400	N0800	410	2.5	1047	410	3.0	923	530	3.0	851	610	3.5	730	610	3.5	631
		N1000		3.0	1409		3.0	1252		3.5	1162		4.0	1010		4.0	885
		N1100		3.0	1589		3.5	1417		3.5	1318		4.0	1150		4.0	1012
		N1200		3.0	1770		3.5	1581		4.0	1473		4.0	1289		4.0	1139
		N1300		4.0	1951		4.0	1746		4.0	1629		4.0	1429		4.0	1266
HVC ---160	1600	N0800	410	2.5	880	410	3.0	771	530	3.0	709	610	3.5	603	700	3.5	516
		N1000		3.0	1198		3.0	1061		3.5	982		4.0	848		4.0	739
		N1100		3.0	1357		3.5	1205		3.5	1119		4.0	971		4.5	851
		N1200		3.0	1515		3.5	1350		4.0	1255		4.0	1094		4.5	962
		N1300		4.0	1674		4.0	1495		4.0	1392		4.0	1217		5.0	1074
HVC ---180	1800	N0800	410	2.5	750	410	3.0	653	530	3.0	598	610	3.5	503	700	3.5	426
		N1000		3.0	1033		3.0	911		3.5	841		4.0	722		4.0	625
		N1100		3.0	1174		3.5	1040		3.5	963		4.0	832		4.5	724
		N1200		3.0	1316		3.5	1169		4.0	1084		4.0	941		4.5	824
		N1300		4.0	1457		4.0	1298		4.0	1206		4.0	1050		5.0	923
HVC ---200	2000	N0800	410	2.5	645	410	3.0	558	530	3.0	508	610	3.5	423	700	3.5	354
		N1000		3.0	900		3.0	790		3.5	727		4.0	621		4.0	533
		N1100		3.0	1028		3.5	907		3.5	837		4.0	719		4.5	623
		N1200		3.0	1156		3.5	1023		4.0	947		4.0	818		4.5	712
		N1300		4.0	1283		4.0	1139		4.0	1057		4.0	917		5.0	802
HVC ---220	2200	N0800	410	2.5	559	410	3.0	480	530	3.0	434	610	3.5	357	700	3.5	294
		N1000		3.0	791		3.0	692		3.5	634		4.0	537		4.0	458
		N1100		3.0	908		3.5	797		3.5	734		4.0	627		4.5	539
		N1200		3.0	1024		3.5	903		4.0	834		4.0	717		4.5	621
		N1300		4.0	1140		4.0	1009		4.0	934		4.0	807		5.0	703
HVC ---240	2400	N800	410	2.5	487	410	3.0	414	530	3.0	373	610	3.5	302	700	3.5	245
		N1000		3.0	700		3.0	609		3.5	556		4.0	467		4.0	395
		N1100		3.0	807		3.5	706		3.5	648		4.0	550		4.5	469
		N1200		3.0	914		3.5	803		4.0	740		4.0	632		4.5	544
		N1300		4.0	1020		4.0	900		4.0	832		4.0	715		5.0	619

The tables illustrate the performance for modules opening under load in accordance with EN 12101-2. The provided performance is NOT equal to structural load bearing capacity of an actual application. The design of a roof light must therefore be dimensioned to fit the specific building project, local architectural style and practice.

Standard size.
  Special sizes, functional limitations may apply.



Product ID	Product Name	Product Code	Product Description
HVC 067---	HVC 075---	HVC 080---	HVC 090---
HVC 100---	HVC 110---	HVC 120---	HVC 130---
HVC 140---	HVC 150---	HVC 160---	HVC 170---
HVC 180---	HVC 190---	HVC 200---	HVC 210---
HVC 220---	HVC 230---	HVC 240---	HVC 250---

## Skylight module



### Opening under load

Glazing unit construction with a total glass thickness of 14 mm																				
Product ID		HVC 067---			HVC 075---			HVC 080---			HVC 090---			HVC 100---						
Height	Size [mm]	Width	675			750			800			900			1000					
	Motor program	Chain stroke [mm]	Electric current requirement [AMP]	Snow Load [Pa]	Chain stroke [mm]	Electric current requirement [AMP]	Snow Load [Pa]	Chain stroke [mm]	Electric current requirement [AMP]	Snow Load [Pa]	Chain stroke [mm]	Electric current requirement [AMP]	Snow Load [Pa]	Chain stroke [mm]	Electric current requirement [AMP]	Snow Load [Pa]				
HVC ---080	800	N0800	353	2.5	353	2.5	353	2.5	353	2.5	353	2.5	353	2.5	353	2.5	353			
		N1000		3.0		1984		3.0		1768		3.0		1644		3.0		1434	3.0	1263
		N1100		3.0		2603		3.0		2332		3.0		2177		3.0		1913	3.0	1698
		N1200		3.0		2913		3.0		2615		3.0		2444		3.0		2153	3.0	1916
		N1300		3.0		3223		3.0		2897		3.0		2710		3.0		2393	3.0	2133
HVC ---100	1000	N0800	410	2.5	439	2.5	439	2.5	439	2.5	439	2.5	439	2.5	439	2.5	439			
		N1000		3.0		1533		3.0		1359		3.0		1260		3.0		1090	3.0	952
		N1100		3.0		2034		3.0		1815		3.0		1690		3.0		1477	3.0	1303
		N1200		3.0		2284		3.5		2043		3.5		1905		3.5		1671	3.5	1479
		N1300		4.0		2534		3.5		2271		3.5		2120		3.5		1864	3.5	1655
HVC ---120	1200	N0800	410	2.5	460	3.0	526	3.0	526	3.0	526	3.0	526	3.0	526	3.0	526			
		N1000		3.0		1228		3.0		1082		3.0		999		3.0		857	3.0	741
		N1100		3.0		1648		3.0		1465		3.5		1360		3.5		1182	3.5	1036
		N1200		3.0		1858		3.5		1656		3.5		1540		3.5		1344	3.5	1184
		N1300		4.0		2068		4.0		1847		4.0		1721		4.0		1506	4.0	1331
HVC ---140	1400	N0800	410	2.5	460	3.0	530	3.0	530	3.0	530	3.0	530	3.0	530	3.0	530			
		N1000		3.0		1008		3.0		882		3.0		811		3.0		689	3.0	589
		N1100		3.0		1369		3.0		1212		3.5		1122		3.5		968	3.5	843
		N1200		3.0		1550		3.5		1377		3.5		1277		3.5		1108	3.5	970
		N1300		4.0		1731		4.0		1541		4.0		1432		4.0		1248	4.0	1097
HVC ---160	1600	N0800	410	2.5	460	3.0	530	3.0	530	3.0	530	3.0	530	3.0	530	3.0	530			
		N1000		3.0		841		3.0		731		3.0		668		3.0		561	3.0	474
		N1100		3.0		1159		3.0		1020		3.5		941		3.5		807	3.5	697
		N1200		3.0		1317		3.5		1165		3.5		1078		3.5		930	3.5	809
		N1300		4.0		1476		3.5		1310		4.0		1214		4.0		1052	4.0	920
HVC ---180	1800	N0800	410	2.5	460	3.0	530	3.0	530	3.0	530	3.0	530	3.0	530	3.0	530			
		N1000		3.0		1635		3.0		1454		3.0		1351		3.0		1175	3.0	1032
		N1100		3.0		711		3.0		613		3.0		557		3.0		462	3.0	384
		N1200		3.0		994		3.0		871		3.5		800		3.5		681	3.5	583
		N1300		4.0		1135		3.5		1000		3.5		922		3.5		790	3.5	682
HVC ---200	2000	N0800	410	2.5	460	3.0	530	3.0	530	3.0	530	3.0	530	3.0	530	3.0	530			
		N1000		3.0		1277		3.5		1128		3.5		1044		3.5		899	3.5	782
		N1100		3.0		1418		4.0		1257		4.0		1165		4.0		1009	4.0	881
		N1200		3.0		606		3.0		518		3.0		467		3.0		382	3.0	312
		N1300		4.0		861		3.0		750		3.5		687		3.5		579	3.5	491
HVC ---220	2200	N0800	410	2.5	460	3.0	530	3.0	530	3.0	530	3.0	530	3.0	530	3.0	530			
		N1000		3.0		1116		3.5		983		3.5		906		3.5		776	3.5	670
		N1100		3.0		1244		3.5		1099		4.0		1016		4.0		875	4.0	760
		N1200		3.0		520		3.0		439		3.0		394		3.0		316	3.0	252
		N1300		4.0		752		3.0		651		3.5		594		3.5		495	3.5	415
HVC ---240	2400	N0800	410	2.5	460	3.0	530	3.0	530	3.0	530	3.0	530	3.0	530	3.0	530			
		N1000		3.0		868		3.5		757		3.5		693		3.5		585	3.5	497
		N1100		3.0		984		3.5		863		4.0		793		4.0		675	4.0	579
		N1200		3.0		1101		4.0		969		4.0		893		4.0		765	4.0	660
		N1300		4.0		447		3.0		374		3.0		332		3.0		261	3.0	202

The tables illustrate the performance for modules opening under load in accordance with EN 12101-2. The provided performance is NOT equal to structural load bearing capacity of an actual application. The design of a roof light must therefore be dimensioned to fit the specific building project, local architectural style and practice.

Standard size.
  Special sizes, functional limitations may apply.

# Skylight module



## Opening under load

Glazing unit construction with a total glass thickness of 18 mm																	
Product ID		HVC 067---			HVC 075---			HVC 080---			HVC 090---			HVC 100---			
Height	Size [mm]	Width	675		750		800		900		900		1000				
	Motor program	Chain stroke [mm]	Electric current requirement [AMP]	Snow Load [Pa]	Chain stroke [mm]	Electric current requirement [AMP]	Snow Load [Pa]	Chain stroke [mm]	Electric current requirement [AMP]	Snow Load [Pa]	Chain stroke [mm]	Electric current requirement [AMP]	Snow Load [Pa]	Chain stroke [mm]	Electric current requirement [AMP]	Snow Load [Pa]	
HVC ---080	800	N0800	353	2.5	1911	353	2.5	1693	353	2.5	1569	353	2.5	1357	353	2.5	1184
		N1000		3.0	2530		3.0	2258		3.0	2102		3.0	1836		3.0	1620
		N1100		3.0	2840		3.0	2540		3.0	2368		3.0	2076		3.0	1837
		N1200		3.0	3150		3.0	2822		3.0	2634		3.0	2316		3.0	2055
		N1300		3.0	3460		3.0	3105		3.0	2901		3.0	2555		3.0	2273
HVC ---100	1000	N0800	410	2.5	1459	439	2.5	1284	439	2.5	1183	439	2.5	1012	439	2.5	872
		N1000		3.0	1960		3.0	1740		3.0	1613		3.0	1399		3.0	1224
		N1100		3.0	2210		3.5	1968		3.5	1829		3.5	1593		3.5	1400
		N1200		3.0	2460		3.5	2196		3.5	2044		3.5	1786		3.5	1576
		N1300		4.0	2710		3.5	2424		3.5	2259		3.5	1980		3.5	1751
HVC ---120	1200	N0800	410	2.5	1153	460	3.0	1006	526	3.0	921	526	3.0	778	526	3.0	661
		N1000		3.0	1573		3.0	1388		3.5	1282		3.5	1103		3.5	956
		N1100		3.0	1783		3.5	1580		3.5	1463		3.5	1265		3.5	1103
		N1200		3.0	1993		3.5	1771		4.0	1644		4.0	1427		4.0	1251
		N1300		4.0	2203		4.0	1962		4.0	1824		4.0	1590		4.0	1398
HVC ---140	1400	N0800	410	2.5	932	460	3.0	805	530	3.0	733	610	3.5	609	610	3.5	508
		N1000		3.0	1294		3.0	1135		3.5	1044		4.0	889		4.0	762
		N1100		3.0	1475		3.5	1299		3.5	1199		4.0	1028		4.0	889
		N1200		3.0	1655		3.5	1464		4.0	1354		4.0	1168		4.0	1016
		N1300		4.0	1836		4.0	1629		4.0	1510		4.0	1308		4.0	1143
HVC ---160	1600	N0800	410	2.5	765	460	3.0	654	530	3.0	590	610	3.5	481	700	3.5	393
		N1000		3.0	1083		3.0	943		3.5	863		4.0	727		4.0	616
		N1100		3.0	1241		3.5	1088		3.5	999		4.0	850		4.5	727
		N1200		3.0	1400		3.5	1232		4.0	1136		4.0	972		4.5	839
		N1300		4.0	1559		4.0	1377		4.0	1272		4.0	1095		5.0	950
HVC ---180	1800	N0800	410	2.5	634	460	3.0	535	530	3.0	478	610	3.5	381	700	3.5	302
		N1000		3.0	917		3.0	793		3.5	721		4.0	600		4.0	501
		N1100		3.0	1059		3.5	922		3.5	843		4.0	710		4.5	600
		N1200		3.0	1200		3.5	1051		4.0	965		4.0	819		4.5	700
		N1300		4.0	1342		4.0	1179		4.0	1086		4.0	928		5.0	799
HVC ---200	2000	N0800	410	2.5	529	460	3.0	440	530	3.0	388	610	3.5	301	700	3.5	230
		N1000		3.0	784		3.0	672		3.5	608		4.0	498		4.0	409
		N1100		3.0	912		3.5	788		3.5	717		4.0	597		4.5	499
		N1200		3.0	1040		3.5	905		4.0	827		4.0	696		4.5	588
		N1300		4.0	1167		4.0	1021		4.0	937		4.0	794		5.0	678
HVC ---220	2200	N0800	410	2.5	443	460	3.0	361	530	3.0	314	610	3.5	235	700	3.5	170
		N1000		3.0	675		3.0	573		3.5	514		4.0	415		4.0	333
		N1100		3.0	792		3.5	679		3.5	614		4.0	504		4.5	415
		N1200		3.0	908		3.5	785		4.0	714		4.0	594		4.5	496
		N1300		4.0	1024		4.0	891		4.0	814		4.0	684		5.0	578
HVC ---240	2400	N800	410	2.5	371	460	3.0	296	530	3.0	253	610	3.5	180	700	3.5	120
		N1000		3.0	584		3.0	490		3.5	436		4.0	345		4.0	270
		N1100		3.0	691		3.5	587		3.5	528		4.0	427		4.5	345
		N1200		3.0	797		3.5	684		4.0	620		4.0	510		4.5	420
		N1300		4.0	904		4.0	782		4.0	711		4.0	592		5.0	495
HVC ---260	2600	N0800	410	2.5	309	460	3.0	240	530	3.0	210	610	3.5	150	700	3.5	110
		N1000		3.0	507		3.0	420		3.5	360		4.0	270		4.0	210
		N1100		3.0	605		3.5	510		3.5	450		4.0	360		4.5	300
		N1200		3.0	704		3.5	599		4.0	540		4.0	450		4.5	390
		N1300		4.0	802		4.0	689		4.0	630		4.0	540		5.0	480
HVC ---280	2800	N0800	410	2.5	257	460	3.0	200	530	3.0	175	610	3.5	125	700	3.5	95
		N1000		3.0	440		3.0	350		3.5	300		4.0	225		4.0	175
		N1100		3.0	532		3.5	425		3.5	375		4.0	300		4.5	250
		N1200		3.0	623		3.5	500		4.0	450		4.0	375		4.5	325
		N1300		4.0	715		4.0	575		4.0	525		4.0	450		5.0	400

The tables illustrate the performance for modules opening under load in accordance with EN 12101-2. The provided performance is NOT equal to structural load bearing capacity of an actual application. The design of a roof light must therefore be dimensioned to fit the specific building project, local architectural style and practice.

Standard size.

Special sizes, functional limitations may apply.

Only applicable for double glazing variants with -T.



## Skylight module



### Smoke ventilation systems

A smoke ventilation system always has a building specific design, incorporating smoke ventilators, controls, air inlets and mechanical ventilation.

Designing a smoke ventilation system is therefore a rather complex matter, which must be addressed by skilled and authorized fire engineers in order to obtain an adequate level of performance and safety.

The design covers all relevant parameters such as the location of the building, height and shape of the roof, position of ventilators on the

roof, relative position to each other, facades and doors providing air intake, mechanical ventilation, evacuation plan and escape routes, and the natural and artificial wind obstacles in the surroundings of the building.

The VELUX Group provides the essential performance characteristics of each individual CE-marked VELUX Modular Skylight in accordance with EN 12101-2, but cannot validate the functionality and safety of the complete system.

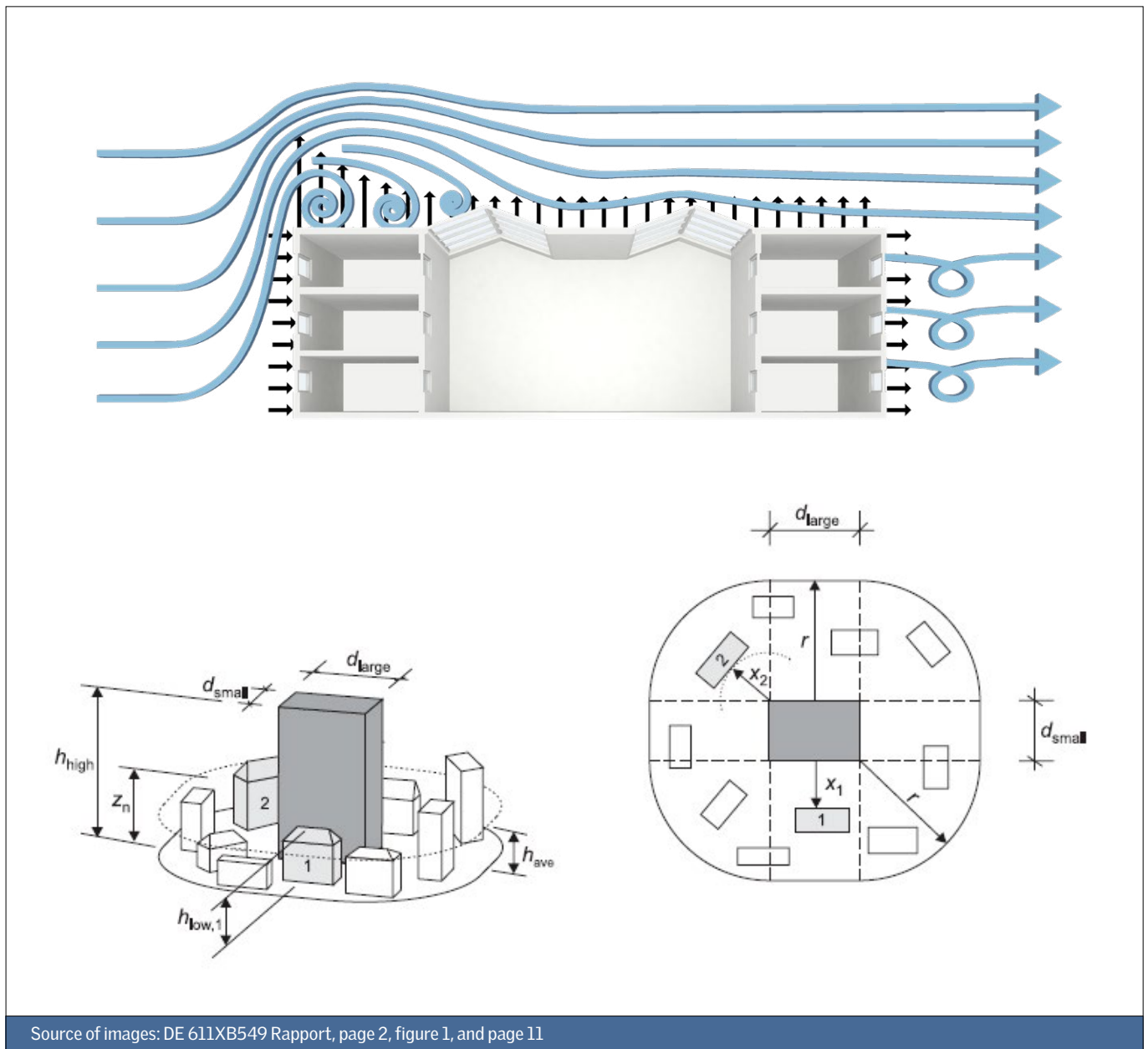

Source of images: DE 611XB549 Rapport, page 2, figure 1, and page 11



## Skylight module



### Wind deflector KCD W00H00 0040

Material	Aluminium
Material thickness	3 mm
Surface treatment	Powder coated (60 - 120µ)
Colour	NCS S7500-N, gloss 30









# Skylight module

## Definitions

### In accordance with EN 12101-2:

**$C_v$  [-]** Coefficient of discharge that states the ratio between  $A_a$  and  $A_v$  ( $C_v = A_a/A_v$ ). For roof-mounted smoke and heat exhaust ventilators the value of  $C_v$  is the lower of  $C_{v0}$  and  $C_{vw}$ .

For wall-mounted smoke and heat exhaust ventilators,  $C_v$  is not to be tested with wind influence i.e.  $C_v = C_{v0}$ .

**$C_{v0}$  [-]** Coefficient of discharge calculated based on pressure testing without side wind influence.

**$C_{vw}$  [-]** Coefficient of discharge calculated based on pressure testing with side wind influence.

**$A_a$  [ $m^2$ ]**  $A_a$  [ $m^2$ ] Aerodynamic free area ( $A_a = A_v \times C_v$ ). May be described as the effective area of the ventilator taking into account reductions in air flow along edges and around the openable panel as well as motors etc.

**$A_v$  [ $m^2$ ]** Geometric area, corresponds to frame aperture area.

### Roof-mounted:

Smoke ventilators installed from  $0^\circ$  up to and including  $60^\circ$ . VELUX Modular Skylights installed from  $5^\circ$  to  $60^\circ$  are proven wind sensitive. This must be considered when planning the smoke ventilation of the building.

### Wall-mounted:

Smoke ventilators installed above  $60^\circ$  up to  $90^\circ$ . Wall-mounted smoke ventilators are, as per definition, wind sensitive regardless of the design.

### In accordance with EN 13141-1

**$A_c$  [ $m^2$ ]** Geometric free area corresponds to the minimum unobstructed opening of the openable modular skylights in natural comfort ventilation position.

The area is calculated using the total opening area of the ventilator, in case of modular skylight top-hung ventilators from the front opening and the side triangles. Not identical to  **$A_g$  [ $m^2$ ], which is calculated in smoke ventilation opening position.**

Used to define natural ventilation performance of comfort venting modular skylights and dual purpose smoke venting modular skylights in comfort ventilation use.

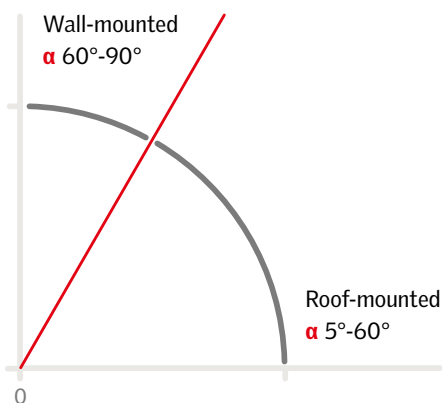



# Skylight module



Table for European values

Ventilation characteristics for HVC (European values)																		
Size of Skylights	Smoke ventilation characteristics HVC-----AB														Comfort ventilation (EN13141-1)			
	Actuator chain stroke [mm]	Opening angle	Geometric area: $A_v$ [m <sup>2</sup> ]	Discharge coefficient ( $C_v$ ) (EN 12101-2)						Aerodynamic free area ( $A_a$ ) [m <sup>2</sup> ] (EN 12101-2)						HVC-----CB and HVC-----AB in comfort function		
				Without deflector		With deflector type KCD 0080		With deflector type KCD 0040		Without deflector			With deflector type KCD 0080		With deflector type KCD 0040	Actuator chain stroke [mm]	Opening angle	Geometric free area: $A_c$ [m <sup>2</sup> ]
				without side wind	with side wind	without side wind	with side wind	without side wind	with side wind	5° ≤ installation inclination ≤ 60°		installation inclination > 60°	5° ≤ installation inclination ≤ 60°		5° ≤ installation inclination ≤ 60°			
				$C_{v0}$	$C_{vw}$	$C_{v0}$	$C_{vw}$	$C_{v0}$	$C_{vw}$	$A_{a, Roof}^{1)}$ without side wind <sup>2)</sup>	$A_{a, Roof}$ with side wind	$A_{a, Wall}^{3)}$	$A_{a, Roof}^{4)}$		$A_{a, Roof}^{4)}$			
675 x 800	353	25.0°	0.48	0.42	0.00	0.49	0.59	0.40	0.26	0.20	0.00	0.20	0.24	0.13	260	18.5°	0.16	
675 x 1000	410	23.0°	0.61	0.44	0.00	0.46	0.60	0.40	0.24	0.27	0.00	0.27	0.28	0.15	260	14.5°	0.17	
675 x 1200	410	19.5°	0.74	0.40	0.00	0.43	0.57	0.38	0.22	0.30	0.00	0.30	0.32	0.16	260	12.5°	0.19	
675 x 1400	410	16.5°	0.87	0.36	0.00	0.40	0.54	0.35	0.20	0.31	0.00	0.31	0.35	0.17	260	10.5°	0.20	
675 x 1600	410	14.5°	1.00	0.33	0.00	0.38	0.52	0.33	0.19	0.33	0.00	0.33	0.38	0.19	260	9.0°	0.22	
675 x 1800	410	13.0°	1.12	0.34	0.00	0.36	0.49	0.34	0.19	0.38	0.00	0.38	0.40	0.21	260	8.0°	0.23	
675 x 2000	410	11.5°	1.25	0.32	0.00	0.33	0.45	0.33	0.16	0.40	0.00	0.40	0.41	0.20	260	7.5°	0.25	
675 x 2200	410	10.5°	1.38	0.31	0.00	0.32	0.43	0.32	0.17	0.43	0.00	0.43	0.44	0.23	260	6.5°	0.26	
675 x 2400	410	9.5°	1.51	0.29	0.00	0.30	0.41	0.30	0.16	0.44	0.00	0.44	0.45	0.24	260	6.0°	0.28	
675 x 2600	410	9.0°	1.64	0.31	0.00	-	-	0.32	0.17	0.50	0.00	0.50	-	0.28	260	5.5°	0.29	
675 x 2800	410	8.0°	1.76	0.28	0.00	-	-	0.31	0.18	0.49	0.00	0.49	-	0.32	260	5.5°	0.31	
750 x 800	353	25.0°	0.54	0.41	0.00	0.47	0.56	0.38	0.26	0.22	0.00	0.22	0.25	0.14	260	18.5°	0.17	
750 x 1000	439	25.0°	0.68	0.46	0.00	0.49	0.61	0.40	0.24	0.31	0.00	0.31	0.33	0.16	260	14.5°	0.19	
750 x 1200	460	21.5°	0.83	0.44	0.00	0.44	0.57	0.41	0.23	0.36	0.00	0.36	0.36	0.19	260	12.5°	0.20	
750 x 1400	460	18.5°	0.97	0.39	0.00	0.41	0.54	0.38	0.22	0.38	0.00	0.38	0.40	0.21	260	10.5°	0.22	
750 x 1600	460	16.0°	1.11	0.37	0.00	0.39	0.51	0.36	0.21	0.41	0.00	0.41	0.43	0.23	260	9.0°	0.23	
750 x 1800	460	14.5°	1.25	0.36	0.00	0.37	0.50	0.35	0.19	0.45	0.00	0.45	0.46	0.24	260	8.0°	0.25	
750 x 2000	460	13.0°	1.40	0.37	0.00	0.36	0.48	0.35	0.19	0.52	0.00	0.52	0.50	0.27	260	7.5°	0.26	
750 x 2200	460	12.0°	1.54	0.37	0.00	0.34	0.46	0.36	0.19	0.57	0.00	0.57	0.52	0.29	260	6.5°	0.27	
750 x 2400	460	11.0°	1.68	0.35	0.00	0.33	0.44	0.35	0.15	0.59	0.00	0.59	0.56	0.25	260	6.0°	0.29	
750 x 2600	460	10.0°	1.83	0.33	0.00	-	-	0.33	0.16	0.60	0.00	0.60	-	0.29	260	5.5°	0.30	

- <sup>1)</sup> External building surfaces with inclination of 60° or less relative to the horizontal; shed roofs and continuous roof-lights, independent of inclination angle, are considered to be part of the roofs.
- <sup>2)</sup> The aerodynamic area has been declared in accordance with EN 12101-2, which means the products have been tested with and without side wind. The aerodynamic area expressed without deflector is wind sensitive which therefore, in connection with the design of the smoke ventilation system, means that steps must be taken to incorporate the products as part of a total solution that can be approved by the local fire authorities. This solution could consist of, for instance, a wind direction sensor, a wind deflector or another device that ensures a sufficient aerodynamic area at all times.  
It is the responsibility of the building owner – together with the local fire authorities, if necessary – to ensure the system is specified, installed and operated in accordance with current national legislation and requirements.
- <sup>3)</sup> External building surfaces with an inclination of more than 60° relative to the horizontal.
- <sup>4)</sup> Aerodynamic tests as outlined in EN 12101-2:2003 were conducted both with wind ( $C_{vw}$ ) and without influence of wind ( $C_{v0}$ ). In any case, the lower of  $C_{v0}$  and  $C_{vw}$  is used.





## Skylight module

### Other relevant aerodynamic areas

The aerodynamic areas below are outside of the scope of EN 12101-2.

They are however used nationally and referred to in national regulations and/or practical guides.

1)  $A_g$  [ $m^2$ ] Geometric free area, corresponds to the minimum unobstructed opening area of the smoke ventilators.

The typical use of this parameter is to define the ventilation area of smoke ventilators when they are used as so called cold smoke exhaust ventilators, assuming that the outtake pressure is generated by mechanical extract fans or generated by a chimney stack effect. A typical use of this area is when smoke ventilators are used over staircases. National and local regulations may differ and wherever they exist, they must be followed.

### Definition of the geometric free area:

Figure 1.a:

Germany: In accordance with DIN 18232

The area is calculated in relation to the use of the total unobstructed opening area of the ventilator. In case of modular skylight top-hung ventilators it equals to the front opening (A) and the side triangles (B + C).

**Not identical to  $A_c$  [ $m^2$ ], which is calculated in comfort opening position.**

Figure 1.b:

Austria: In accordance with the Guideline TRVB S 111 + addendum 3.3.2018 to point 5.4

The area is calculated in relation to the use of the total unobstructed opening area of the ventilator with some limitations depending on the size and installation inclination and the relation of the opening angle to the installation inclination.

In case of modular skylight top-hung ventilators the value is equal to

- The front opening (A) when the  $A_v \leq 1m^2$
- The front opening (A) when the  $A_v > 1m^2$  and the sash remains below horizontal position
- The front opening (A) plus one of the two side triangles (B) when  $A_v > 1m^2$  and the sash raises minimum up to horizontal level or above

Figure 1.c:

Belgium: In accordance with NBN S21-208-3

The area is calculated in relation to the use of the total unobstructed opening area of the ventilator. In case of modular skylight top-hung

ventilators it equals to the front opening (A).

Figure 2:

Great Britain: Free area of smoke ventilators

- Great Britain: In accordance with Approved Document B, Volume 2, Appendix C, Section 5.b, Diagram C7, figure a

The area is usable as an alternative to the first place cited Aerodynamic Free ( $A_a$ ) in accordance with BS EN 12101-2 under Section 5.a. whenever it is specified in the requirements.



Code	Product Name	Material	Weight [kg]	Dimensions [mm]
...	...	...	...	...

## Skylight module



1.a:



Smoke ventilation

Geometric free area:  $A_g$  [m<sup>2</sup>] in Germany

In accordance with DIN 18232

Geometric free area:  $A_g$  [m<sup>2</sup>] in Denmark

In accordance with DBI 027

1.b:



Smoke ventilation

Geometric area:  $A_g$  [m<sup>2</sup>] in Austria

In accordance with Guideline TRVB S 111  
+ addendum 3.3.2018 to point 5.4.

1.c:



Smoke ventilation

Geometric area:  $A$  [m<sup>2</sup>] in Belgium

In accordance with NBN S21-208-3

2:

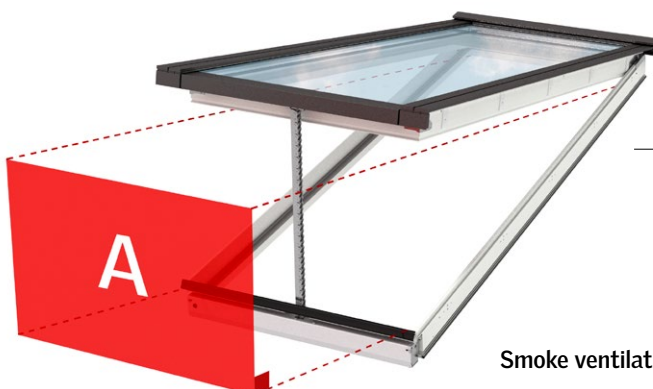

Smoke ventilation

Geometric free area:  $A_g$  [m<sup>2</sup>] in Great Britain

In accordance with Approved Document B,  
Volume 2, Appendix D, Section 5.b,  
Diagram D7, figure a

# Skylight module



Table for country specific values

Basic geometry data				Additional national smoke ventilation characteristics HVC-----AB					
Size of Skylights	Actuator chain stroke [mm]	Opening angle	Geometric area: $A_v$ [m <sup>2</sup> ] (EN 12101-2)	Germany	Denmark	Belgium	Austria		Great Britain
				DIN 18232	DBI 027	NBN S21-208-3:2018	Guideline TRVB S 111 + addendum 3.3.2018 to point 5.4.		
				Geometric free area: $A_g$ [m <sup>2</sup> ]	Cold smoke exhaust area: $A_g$ [m <sup>2</sup> ]	Geometric free area (A) in accordance with NBN S21-208-3:2018	The installation inclination of the module is smaller than the opening angle of the sash relative to horizontal, i.e the sash raises above horizontal in fully opened position.	The installation inclination of the module is equal or larger than the opening angle of the sash relative to horizontal, i.e the sash remains below or raises maximum up to horizontal in fully opened position	The Free Area Smoke Ventilator in accordance with Approved Document B, Volume 2, Appendix D, Section 5.b, Diagram D7, figure a.
							Geometric area: $A_g$ [m <sup>2</sup> ]		Geometric free area: $A_g$ [m <sup>2</sup> ] *
675 x 800	353	25.0°	0.48	0.28	0.28	0.16	0.16	0.16	0.14
675 x 1000	410	23.0°	0.61	0.39	0.39	0.20	0.20	0.20	0.18
675 x 1200	410	19.5°	0.74	0.44	0.44	0.20	0.20	0.20	0.17
675 x 1400	410	16.5°	0.87	0.48	0.48	0.20	0.20	0.20	0.17
675 x 1600	410	14.5°	1.00	0.52	0.52	0.20	0.20	0.20	0.17
675 x 1800	410	13.0°	1.12	0.56	0.56	0.20	0.38	0.20	0.17
675 x 2000	410	11.5°	1.25	0.60	0.60	0.20	0.40	0.20	0.16
675 x 2200	410	10.5°	1.38	0.64	0.64	0.20	0.42	0.20	0.16
675 x 2400	410	9.5°	1.51	0.68	0.68	0.20	0.44	0.20	0.16
675 x 2600	410	9.0°	1.64	0.72	0.72	0.20	0.46	0.20	0.16
675 x 2800	410	8.0°	1.76	0.76	0.76	0.20	0.48	0.20	0.16
750 x 800	353	25.0°	0.54	0.30	0.30	0.18	0.18	0.18	0.16
750 x 1000	439	25.0°	0.68	0.46	0.46	0.24	0.24	0.24	0.22
750 x 1200	460	21.5°	0.83	0.55	0.55	0.26	0.26	0.26	0.23
750 x 1400	460	18.5°	0.97	0.60	0.60	0.26	0.26	0.26	0.23
750 x 1600	460	16.0°	1.11	0.65	0.65	0.26	0.45	0.26	0.22
750 x 1800	460	14.5°	1.25	0.70	0.70	0.26	0.48	0.26	0.22
750 x 2000	460	13.0°	1.40	0.75	0.75	0.26	0.50	0.26	0.22
750 x 2200	460	12.0°	1.54	0.80	0.80	0.26	0.53	0.26	0.22
750 x 2400	460	11.0°	1.68	0.85	0.85	0.26	0.55	0.26	0.22
750 x 2600	460	10.0°	1.83	0.90	0.90	0.26	0.58	0.26	0.22
800 x 800	353	25.0°	0.58	0.31	0.31	0.20	0.20	0.20	0.17
800 x 1000	439	25.0°	0.73	0.48	0.48	0.26	0.26	0.26	0.24
800 x 1200	526	25.0°	0.88	0.69	0.69	0.33	0.33	0.33	0.31
800 x 1400	530	21.5°	1.04	0.76	0.76	0.33	0.54	0.33	0.30
800 x 1600	530	19.0°	1.19	0.82	0.82	0.33	0.58	0.33	0.30
800 x 1800	530	16.5°	1.34	0.89	0.89	0.33	0.61	0.33	0.29
800 x 2000	530	15.0°	1.50	0.95	0.95	0.33	0.64	0.33	0.29
800 x 2200	530	13.5°	1.65	1.01	1.01	0.33	0.67	0.33	0.29
800 x 2400	530	12.5°	1.80	1.08	1.08	0.33	0.70	0.33	0.29

\* Note that this particular calculation of the The Free Area Smoke Ventilator in accordance with Approved Document B, Volume 2, Appendix D, Section 5.b, Diagram D7, figure a. is only a secondary alternative to the in the first place cited Aerodynamic Free (Aa) in accordance with BS EN 12101-2 under Section 5.a. Furthermore, the calculation in accordance to 5.d diagram D7, figure a. cannot take into consideration individual lining depths used in specific interior design cases, which may give further limitations to the values presented above.

Product Name	VELUX S 111	Product Code	111
Product Description	Free Area Smoke Ventilator	Product Weight	1.5 kg
Product Dimensions	900 x 800 mm	Product Height	353 mm
Product Material	Aluminum	Product Color	White
Product Features	Adjustable, Easy to Install	Product Warranty	5 Years
Product Certifications	EN 12101-2, DIN 18232	Product Origin	Denmark
Product Availability	In Stock	Product Lead Time	2-3 Weeks
Product Price	€ 120.00	Product Tax	€ 12.00
Product Notes	See technical drawing for details	Product Contact	VELUX Commercial

## Skylight module

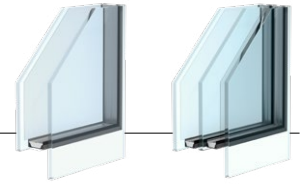





Table for country specific values





Additional ventilation characteristics HVC				Additional national smoke ventilation characteristics HVC-----AB					
Basic geometry data				Germany	Denmark	Belgium	Austria		Great Britain
Size of Skylights	Actuator chain stroke [mm]	Opening angle	Geometric area: Av [m²] (EN 12101-2)	DIN 18232	DBI 027	NBN S21-208-3:2018	Guideline TRVB S 111 + addendum 3.3.2018 to point 5.4.		The Free Area Smoke Ventilator in accordance with Approved Document B, Volume 2, Appendix D, Section 5.b, Diagram D7, figure a.
				Geometric free area: Ag [m²]	Cold smoke exhaust area: A <sub>q</sub> [m²]	Geometric free area (A) in accordance with NBN S21-208-3:2018	The installation inclination of the module is smaller than the opening angle of the sash relative to horizontal, i.e. the sash raises above horizontal in fully opened position.	The installation inclination of the module is equal or larger than the opening angle of the sash relative to horizontal, i.e. the sash remains below or raises maximum up to horizontal in fully opened position.	
900 x 800	353	25.0°	0.65	0.34	0.34	0.22	0.22	0.22	0.20
900 x 1000	439	25.0°	0.83	0.52	0.52	0.30	0.30	0.30	0.27
900 x 1200	526	25.0°	1.00	0.73	0.73	0.37	0.37	0.37	0.35
900 x 1400	610	24.5°	1.17	0.98	0.98	0.44	0.71	0.44	0.42
900 x 1600	610	21.5°	1.35	1.05	1.05	0.44	0.75	0.44	0.41
900 x 1800	610	19.0°	1.52	1.13	1.13	0.44	0.79	0.44	0.41
900 x 2000	610	17.0°	1.69	1.21	1.21	0.44	0.83	0.44	0.40
900 x 2200	610	16.0°	1.86	1.29	1.29	0.44	0.87	0.44	0.40
900 x 2400	610	14.5°	2.04	1.37	1.37	0.44	0.91	0.44	0.40
1000 x 800	353	25.0°	0.73	0.36	0.36	0.25	0.25	0.25	0.22
1000 x 1000	439	25.0°	0.92	0.55	0.55	0.33	0.33	0.33	0.30
1000 x 1200	526	25.0°	1.11	0.77	0.77	0.41	0.59	0.41	0.39
1000 x 1400	610	25.0°	1.31	1.02	1.02	0.49	0.76	0.49	0.47
1000 x 1600	700	24.0°	1.50	1.32	1.32	0.58	0.95	0.58	0.56
1000 x 1800	700	22.0°	1.69	1.42	1.42	0.58	1.00	0.58	0.55
1000 x 2000	700	20.0°	1.89	1.51	1.51	0.58	1.05	0.58	0.55
1000 x 2200	700	18.0°	2.08	1.61	1.61	0.58	1.10	0.58	0.54
1000 x 2400	700	16.5°	2.27	1.71	1.71	0.58	1.14	0.58	0.54



\* Note that this particular calculation of the The Free Area Smoke Ventilator in accordance with Approved Document B, Volume 2, Appendix D, Section 5.b, Diagram D7, figure a. is only a secondary alternative to the in the first place cited Aerodynamic Free (Aa) in accordance with BS EN 12101-2 under Section 5.a. Furthermore, the calculation in accordance to 5.d diagram D7, figure a. cannot take into consideration individual lining depths used in specific interior design cases, which may give further limitations to the values presented above.

# Glazing unit



Coating options	Colour code	Explanation
LowE		Low-emissivity coating
Sun1		Light sun protection coating
Sun2		Enhanced sun protection coating







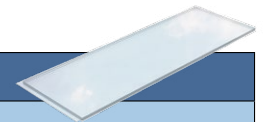

Glazing description	Colour code	Explanation	Characteristic bending strength
F		Float	45.0 N/mm <sup>2</sup>
H		Toughened	120.0 N/mm <sup>2</sup>
HS		Heat Strengthened	70.0 N/mm <sup>2</sup>
Int		Fire protection gel	-

Gas description	Colour code
Argon	
Krypton	

Foil	Colour code	Explanation
Polyvinyl butyral (PVB)		Lamination foil between the sheets of the laminated glass



## Example of glazing unit construction

Description, from outside - inside	
Glazing variant	IGU 16L
Construction	6H LowE - 14 Argon - 6HS - 14 Argon - 6.76F LowE (33.2)
Description	Visual colour description
6H	6 mm pane with toughened glass 
LowE	Low-emissivity coating 
14 Argon	14 mm Argon filled cavity 
6HS	6 mm pane with heat strengthened glass 
14 Argon	14 mm Argon filled cavity 
6.76F (33.2)	Laminated glass, 3 mm float – 2 x 0.38 PVB foil – 3 mm float 
LowE	Low-emissivity coating 
Description, from outside - inside	Visual colour description, from outside - inside
Construction colour code	6H LowE - 14 Argon - 6HS - 14 Argon - 6.76F LowE (33.2) 

Product Name	IGU 2400 x 2400 mm	IGU 2400 x 1800 mm	IGU 1800 x 1800 mm
Product Code	IGU 2400 x 2400 mm	IGU 2400 x 1800 mm	IGU 1800 x 1800 mm
Product Description	IGU 2400 x 2400 mm	IGU 2400 x 1800 mm	IGU 1800 x 1800 mm
Product Weight	IGU 2400 x 2400 mm	IGU 2400 x 1800 mm	IGU 1800 x 1800 mm
Product Dimensions	IGU 2400 x 2400 mm	IGU 2400 x 1800 mm	IGU 1800 x 1800 mm
Product Material	IGU 2400 x 2400 mm	IGU 2400 x 1800 mm	IGU 1800 x 1800 mm
Product Color	IGU 2400 x 2400 mm	IGU 2400 x 1800 mm	IGU 1800 x 1800 mm
Product Finish	IGU 2400 x 2400 mm	IGU 2400 x 1800 mm	IGU 1800 x 1800 mm
Product Lead Time	IGU 2400 x 2400 mm	IGU 2400 x 1800 mm	IGU 1800 x 1800 mm
Product Warranty	IGU 2400 x 2400 mm	IGU 2400 x 1800 mm	IGU 1800 x 1800 mm

## Glazing unit



Glazing units						
		Double Glazing = DG		Triple Glazing = TG		
TG/ DG	Coating	Construction		Glass thickness	Visual colour description	
		IGU	Insulating Glass Unit (IGU)			Insulating Glass Unit (IGU)
		code	(outside - inside)			(outside - inside)
DG	LowE	10L	6H - 22 Argon - 6.76F LowE (33.2)	12		
DG	LowE	10T	8H - 16 Argon - 10.76F LowE (55.2)	18		
TG	LowE	16L	6H LowE - 14 Argon - 6HS - 14 Argon - 6.76F LowE (33.2)	18		
TG	LowE	16K	8H LowE - 12 Krypton - 4HS - 12 Krypton - 10.76HS LowE (55.2)	22		
TG	LowE	16T	8H LowE - 12 Argon - 4HS - 12 Argon - 10.76HS LowE (55.2)	22		
DG	Sun1	11L	6H Sun1 - 22 Argon - 6.76F (33.2)	12		
DG	Sun1	11T	8H Sun1 - 16 Argon - 10.76F (55.2)	18		
TG	Sun1	17L	6H Sun1 - 14 Argon - 6HS - 14 Argon - 6.76F LowE (33.2)	18		
TG	Sun1	17K	8H Sun1 - 12 Krypton - 4HS - 12 Krypton - 10.76HS LowE (55.2)	22		
TG	Sun1	17T	8H Sun1 - 12 Argon - 4HS - 12 Argon - 10.76HS LowE (55.2)	22		
DG	Sun2	12T	8H Sun2 - 16 Argon - 10.76F (55.2)	18		
TG	Sun2	18T	8H Sun2 - 12 Argon - 4HS - 12 Argon - 10.76HS LowE (55.2)	22		

Fire resistant glazing units used in fire resistant modules HFS						
TG/ DG	Coating	Construction		Glass thickness	Visual colour description	
		IGU	Insulating Glass Unit (IGU)			Insulating Glass Unit (IGU)
		code	(outside - inside)			(outside - inside)
DG	LowE	10U	6H LowE - 9 Krypton - 5H - Int.6 - 8.76F (44.2)			
DG	Sun1	11U	6H Sun1 - 9 Krypton - 5H - Int.6 - 8.76F (44.2)			
DG	Sun2	12U	6H Sun2 - 9 Krypton - 5H - Int.6 - 8.76F (44.2)			

# Glazing unit

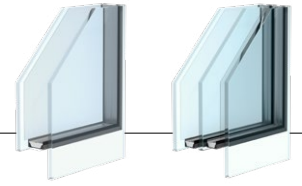

Glazing units																
Double glazing = DG / Triple glazing = TG	Coating	IGU code	Thermal transmittance $U_g$ W/m <sup>2</sup> K	Psi value $\psi$ W/mK	Thermal transmittance of the entire window in accordance with EN 14351-1		Light transmittance $\tau_v$ %	Solar factor $g$ %	UV transmittance $\tau_{uv}$ %	Colour rendering index $R_a$	Direct airborn sound reduction IGU $R_w$ (C, C <sub>tr</sub> ) dB	Acoustic performance window <sup>1), 2)</sup> $R_w$ (C, C <sub>tr</sub> ) dB	Rain noise $L_{ia}$ dB	Total solar energy direct absorption $a$ %	Resistance to pendulum body impact Class Outside/Inside	Resistance to burglary Class Inside
					area > 2.3 m <sup>2</sup>	area ≤ 2.3 m <sup>2</sup>										
					$U_w$ W/m <sup>2</sup> K	$U_w$ W/m <sup>2</sup> K										
DG	LowE	10L	1.1	0.059	1.4	1.4	80	61	0.0	97	35 (-3;-7)	35 (-1;-5)	52	23	1C1/1B1	P2A
DG	LowE	10T	1.0	0.066	1.3	1.4	73	51	0.0	94	41 (-1;-4)	38 (-1;-4)	49	29	1C1/1B1	P2A
TG	LowE	16L	0.6	0.060	0.89	0.98	72	52	0.0	96	37 (-2;-6)	36 (-1;-4)	49	29	1C2/NPD/1B1	P2A
TG	LowE	16K	0.5	0.080	0.86/0.87 <sup>3)</sup>	0.96/0.99 <sup>3)</sup>	70	49	0.0	96	42 (-2;-6)	38 (-1;-4)	48	30	1C2/NPD/1B1	P2A
TG	LowE	16T	0.7	0.080	1.0	1.1	70	49	0.0	96	42 (-2;-6)	38 (-1;-4)	48	30	1C2/NPD/1B1	P2A
DG	Sun1	11L	1.1	0.059	1.4	1.4	52	28	0.0	84	35 (-3;-7)	35 (-1;-5)	52	46	1C2/1B1	P2A
DG	Sun1	11T	1.0	0.066	1.3	1.4	51	28	0.0	83	40 (-1;-5)	38 (-1;-4)	49	48	1C2/1B1	P2A
TG	Sun1	17L	0.6	0.060	0.89	0.98	46	25	0.0	88	37 (-2;-6)	36 (-1;-4)	49	46	1C2/NPD/1B1	P2A
TG	Sun1	17K	0.5	0.080	0.86/0.87 <sup>3)</sup>	0.96/0.99 <sup>3)</sup>	45	24	0.0	88	42 (-2;-6)	38 (-1;-4)	48	48	1C2/NPD/1B1	P2A
TG	Sun1	17T	0.7	0.080	1.0	1.1	45	24	0.0	88	42 (-2;-6)	38 (-1;-4)	48	48	1C2/NPD/1B1	P2A
DG	Sun2	12T	1.1	0.066	1.4	1.5	18	17	0.0	92	41 (-1;-4)	38 (-1;-4)	49	59	1C1/1B1	P2A
TG	Sun2	18T	0.7	0.080	1.0	1.1	16	14	0.0	93	42 (-2;-6)	38 (-1;-4)	48	61	1C1/NPD/1B1	P2A

Fire resistant glazing units used in fire resistant modules HFS											
Coating	IGU code	$U_g$ W/m <sup>2</sup> K	$\psi$ W/mK	$U_w$ Area > 2.3m <sup>2</sup>	$U_w$ Area ≤ 2.3m <sup>2</sup>	$\tau_v$ %	$g$ %	$\tau_{uv}$ %	$R_a$	$a$ %	
				W/m <sup>2</sup> K	W/m <sup>2</sup> K						
DG	LowE	10U	1.0	0.083	1.3	1.4	76	60	-	96	29
DG	Sun1	11U	1.0	0.083	1.3	1.4	65	40	-	92	37
DG	Sun2	12U	1.0	0.083	1.3	1.4	57	33	-	90	40

## Notes:

<sup>1)</sup> For product sizes A ≤/ = 2.7 m<sup>2</sup>. For product sizes of 2.7m<sup>2</sup> < A < 3.6 m<sup>2</sup>, the sound insulation values must be deducted by 1 dB

<sup>2)</sup> The R<sub>w</sub>+C-value indicates the number of decibels by which a window will reduce apparent noise.

R<sub>w</sub>+C is an adjustment factor to account for high frequency noise sources e.g. living activities (talking, music, radio, TV), railway traffic at medium to high speed, road traffic exceeding 80 km/h or a jet aircraft.

R<sub>w</sub>+C<sub>tr</sub> is an adjustment factor to account for low frequency noise sources e.g. urban road traffic or railway traffic at low speeds.

<sup>3)</sup> HFC/HVC

## General notes:

- It is up to the customer to verify the chosen fire resistant glazing unit against the project specific conditions following the national requirement.
- Production height for calculation of climatic load is from 0 to 300 metre above sea level.
- Modules higher than 2400 mm will be delivered with a T-pane.
- Other insulating glass units are available, contact your VELUX sales office for more details.

Under normal conditions the free vision through the glass in a HFS module will not be adversely affected.

The term normal conditions implies that the gel layer may not be allowed to reach temperatures below -10°C or above + 45°C.





## Frame & sash – interior colours

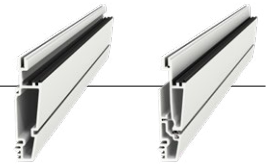

### Standard colours



#### Frame and Sash **White**

Material: Pultruded composite (approx. 80% fibreglass and 20% polyurethane)  
Surface: Waterbased white coating  
Colour: RAL 9010, gloss 30

### Semi-standard colours (Available at additional cost)

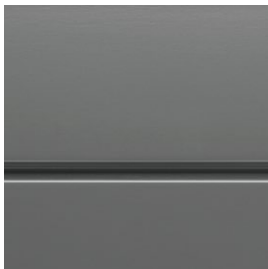

#### Frame and Sash **Light grey**

Material: Pultruded composite (approx. 80% fibreglass and 20% polyurethane)  
Surface: Waterbased light grey coating  
Colour: RAL 7037, gloss 30



#### Frame and Sash **Dark grey**

Material: Pultruded composite (approx. 80% fibreglass and 20% polyurethane)  
Surface: Waterbased dark grey coating  
Colour: RAL 7021, gloss 30

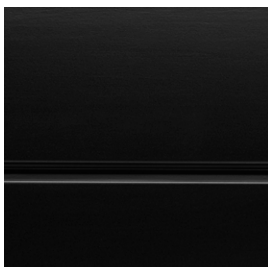

#### Frame and Sash **Black**

Material: Pultruded composite (approx. 80% fibreglass and 20% polyurethane)  
Surface: Waterbased black coating  
Colour: RAL 9005, gloss 30

### Special colours



#### **Special colours**

All other colours can be ordered at additional price, though with exception of mother-of-pearl, effect and metallic colours, neon colours, and colours with other substances than pigment.  
Contact our sales team for more details.



## Vapour barrier connection strip



	BCX	BSX
Membrane	Polyethylene (PE-LD) 150 µm	Multilayer foil containing polyethylene and aluminium, 0.15 mm thick
Gasket	Welded EPDM rubber seal gasket	Welded EPDM rubber seal gasket
Height	200 mm	200 mm
Length	10,000 mm (10 m)	10,000 mm (10 m)
Classification	BCX is CE-marked in accordance with EN 13984	BSX is CE-marked in accordance with EN 13984
Resistance	Water vapour resistance Sd = 80 m	Water vapour resistance Sd = >1500 m
Reaction to fire	Class E	Class E

## Chain actuator



Venting modular skylights and roller blinds can be powered and controlled from either a VELUX io-homecontrol® or an Open system control system.

With VELUX io-homecontrol® the actuator is powered and controlled with control unit KLC 410 and operated with a VELUX control pad. With Open system the actuator can be powered and controlled with either a ±24 V DC or a MotorLink™ control system.

### VELUX io-homecontrol® / Open system

Material	Anodised aluminium housing with zinc chromate passivated steel chain
Weight	Max 5.5 kg
Control system	VELUX io-homecontrol®, MotorLink™ or ±24 V DC*
Supply cable	1.2 m grey silicone cable, 3 cord, 0.75 mm <sup>2</sup> (white brown green**)
Chain stroke	HVC ----CB (comfort) 260 mm HVC ----AB (smoke and comfort) up to 700 mm (depending on module size)
Opening speed	HVC ----CB (comfort) 7 mm/s HVC ----AB (smoke and comfort) up to 13 mm/s
Sound level	32 dB (min speed)***
Holding force (tractive)	5000 N (burglary strength) min
Pressure force	1000 Newton* (smoke ventilation: 1300 Newton)
Tractive force	300-1000 Newton
IP rating	IPX4
Operation conditions	-15°C - +76°C, max. 90% relative humidity (not condensing)
Nominal voltage	24 V DC (max 10% ripple) ****
Voltage	19-32 V DC
Max voltage	32 V DC
Switch-on-duration	ED max 20% (2 minutes per 10 minutes)
Current consumption	HVC ----CB (comfort) max. 2A HVC ----AB (smoke and comfort) 2.5 - 5.5A depending on module size, glazing variant and required snow load
Service	It is recommended to carry out a function test of the actuator at least once a year and to make sure that the skylight opens correctly.
CE marking	The product is tested with the original WindowMaster control units and complies with the EMC directive's requirements for use in residential, commercial and light commercial buildings.
Reservation	The VELUX Group reserves the right to make technical changes.

Product name	Model	Accessories	Accessories
...	...	...	...

## Chain actuator



\*At standard ± 24 V DC connection maximum distances from venting skylight to power supply in accordance to calculation:

$$\text{Max cable length} = \frac{(\text{admissible voltage drop (UL)} \times \text{conductivity of copper (56)} \times \text{cable cross-section (a)})}{(\text{total max. actuator current (I)} \text{ in amps} \times \tau^2)}$$

At MotorLink™ (3 cord) connection maximum distances from roller blind to motor controller (power supply) is 50 m.

\*\*Green = communication wire

\*\*\* The sound level can vary depending on the opening speed and building conditions

\*\*\*\*The provided characteristics for Opening under load and related current consumptions on pages 82-85 are tested and valid for 24 V DC nominal voltage.

### Preconditions for drive time for comfort ventilation with a smoke venting module

When using a smoke ventilation skylight module HVC AB for comfort ventilation, it must be ensured that the comfort opening is in accordance with the tables on pages 96-97 of the Technical Handbook.

The chain stroke for comfort opening function must be limited accordingly by the control system time to maintain lifetime expectancy and guarantee of the modules, and for example can be done by limiting the drive time in most simple control setup.

The provided drive times to the right are examples valid for the default strongest motor variant N1300.

When a lower power consumption motor variant is configured and used, the chain will travel at a lower speed depending in the size of the module. Therefore, in these situations the appropriate drive time to reach the comfort opening must be established by the installer of the control system and set accordingly.

The actuator is lifetime tested for comfort ventilation with a chain stroke up to 530 mm.

### Maximum drive time for comfort ventilation (HVC ---AB)

Module height	Chain stroke [mm]	Drive time [sec]
800	260	20
1000	260	20
1200	260	20
1400	260	20
1600	260	20
1800	260	20
2000	260	20
2200	260	20
2400	260	20
2600	260	20
2800	260	20

## Control system



### Control pad KLR 200

<b>Material and colour</b>	ABS, white (NCS S 1000-N), black (RAL 9005) and metallic grey
<b>Size and weight</b>	Product including packaging: 235 x 153 x 48 mm (W x H x D), 250 g Control pad: 95 x 95 x 23 mm (W x H x D), 180 g
<b>Use</b>	For indoor use, maximum ambient temperature 50°C Radio frequency range: 200 m range open field. Depending on the building construction, the indoor range is approximately 20 m Maximum number of products is 200*
<b>Battery requirement</b>	3 x Alkaline AA (1.5 V) batteries Expected battery lifetime: Approximately 1 year
<b>Compatibility</b>	Based on radio frequency (RF) technology, transmitted in 868 MHz range. Compatible with products with the io-homecontrol® logo.
<b>CE marking</b>	CE-marked to indicate that it is in accordance with the following EU directives: CPR, LVD, MD, RoHS, WEEE, R&TTE, Packaging waste directive and EMC for household, trade and light industry. Combinations of VELUX electrical products meet the requirements of above-mentioned directives.
<b>Note</b>	This product has been designed for use with genuine VELUX products. The connection to other products may cause damage or malfunction. The VELUX Group reserves the right to make technical changes.

\* Maximum recommended number of products is 100 and for daily use it is 50.

## Control system



Control pad KLR 300	
Material and colour	ABS, white (NCS S 1000-N)
Size and weight	Product including packaging: 92 x 74 x 99 mm , 331 g Control pad: 81 x 81 x 17 mm (W x H x D) , 112 g
Use	For indoor use, maximum ambient temperature 50°C. Radio frequency range: 100 m range open field. Depending on the building construction, the indoor range is approximately 10 m. Maximum number of products is 200*
Battery requirements	2 x alkaline AAA (1.5 V) batteries Expected battery lifetime: Approximately 1 year
Compatibility	Based on radio frequency (RF) technology, transmitted in 868 MHz range. Compatible with products with the io-homecontrol® logo.
CE marking	CE-marked to indicate that it is in accordance with the following EU directives: CPR, LVD, MD, RoHS, WEEE, R&TTE, Packaging waste directive and EMC for household, trade and light industry. Combinations of VELUX electrical products meet the requirements of above-mentioned directives.
Note	This product has been designed for use with genuine VELUX products. Connection to other products may cause damage or malfunction. The VELUX Group reserves the right to make technical changes.

\* Maximum 99 of the same product type can be connected at once.

## Control system



Power supply and control unit KLC 410	
Material and colour	Black fire resistant polycarbonate
Size and weight	Product including packaging: 92 x 99 x 74 mm (W x H X D), 331 g Control pad: 81 x 81 x 17 mm (W x H x D), 112g
Installation	24 V DC SELV class III construction output. The control unit is for use in small/medium installations with VELUX Modular Skylights. The control unit can be installed under the flashing of VELUX Modular Skylights or inside the building, at a maximum cable distance of 20 m from the chain actuator. The control unit functions at temperatures between -15°C and +50°C. ta=40°C. The control unit is equipped with a 2.2 m 2-core cable (2 x 1.5 mm² H05VV-F) and plug for connection to the mains supply. Radio frequency range: 300 m range open field. Depending on the building construction, the indoor range is approximately 30 m.
IP rating	IPX4
Power supply characteristics	Primary side: 230/240 V AC - 50 Hz / 250W Secondary side: 24 V DC - 10 A class III construction output.
Connection	The control unit is only to be used with VELUX Modular Skylights and VELUX roller blinds RMM. The control unit can supply power to one venting skylight module and/or up to four roller blinds RMM. The connection wires are pre-fitted with wire-to-wire connectors. The connection wires to the chain actuator and the roller blinds RMM can be extended up to 20 m with a 2 x 1.5 mm² cable.
Compatibility	KLC 410 is based on radio frequency (RF) technology and signals are transmitted in the 868 MHz range. It can be used with VELUX Modular Skylights chain actuator and roller blinds RMM. VELUX electrical products connected to KLC 410 can be operated by io-homecontrol® compatible activation controls.
CE marking	CE-marked to indicate that it is in accordance with the following EU directives: CPR, LVD, MD, RoHS, WEEE, R&TTE, Packaging waste directive and EMC for household, trade and light industry. Combinations of VELUX electrical products meet the requirements of above-mentioned directives.
Note	The VELUX Group reserves the right to make technical changes.



Product Code	Product Name	Product Description	Product Dimensions	Product Weight
10000000000000000000	VELUX io-homecontrol® and Open System	VELUX io-homecontrol® and Open System	1000 x 1000 x 1000	1000

## Roller blind



### VELUX io-homecontrol® and Open System

<b>Materials (visible parts)</b>	Fabric	Polyester
	Wire	Stainless steel
	Bottom rail	Anodized aluminium
	Top pulley wheels	Stainless steel
<b>Colours (cloth)</b>	Grey, white and black (silver on the backside of the black)	
<b>Weight</b>	Max 3.4 kg	
<b>Installation</b>	Please see installation instructions	
<b>Compability</b>	All VELUX Modular Skylights with VELUX io-homecontrol® control system and ±24 V DC control systems	
<b>Control system</b>	VELUX io-homecontrol® or ±24 V DC	
<b>Supply cable</b>	0.2 m cable, 2-core, 0.75 mm <sup>2</sup> (white)	
<b>RMM cable on skylight module*, ***</b>	0.35 - 1.35 m cable, 3-core, 0.75 mm <sup>2</sup> (white, brown, green**)	
<b>Running speed</b>	70 mm/sec.	
<b>IP rating</b>	IPX0	
<b>Sound level</b>	< 70 dB	
<b>Operating conditions</b>	-5°C - +75°C, max. 90% relative humidity (not condensing)	
<b>Nominal voltage</b>	24 V DC (max 10% ripple)	
<b>Voltage</b>	19-24 V DC	
<b>Switch-on-duration</b>	ED max 20% (2 minutes per 10 minutes)	
<b>Electric current requirement</b>	Max 1A	
<b>Service</b>	It is recommended to carry out a function test of the roller blind at least once a year and to make sure that the roller blind runs correctly.	
<b>CE marking</b>	The product is tested with genuine VELUX control units and a ±24 V DC control system and complies with the EMC directive's requirements for use in residential, commercial and light commercial buildings.	
<b>UL approval</b>	VELUX roller blind RMM is approved in accordance to UL 325, Door, Drapery, Gate, Louver, and Window Operators and Systems.	
<b>Reservation</b>	The VELUX Group reserves the right to make to technical changes.	

\* For Open system ± 24 V DC connection, the maximum distance from roller blind to power supply is in accordance to the following calculation:

$$\text{Max. cable length} = \frac{\text{admissible voltage drop (UL)} \times \text{conductivity of copper (56)} \times \text{cable cross-section (a)}}{\text{total max. actuator current (I) in amps} \times 2}$$

\*\* Green cable has no function

\*\*\* Only valid for pre-wired modules

# Roller blind



## Roller blind cloth properties

Colour	White (8806)	Grey (8805)	Black (8807)
--------	--------------	-------------	--------------

## Radiation properties without glazing unit (%)

Total solar energy transmittance (g-value)	37%	31%	15%
Light transmittance in visible light spectrum ( $\tau_v$ )	36%	10%	1%
Light transmittance in full light spectrum ( $\tau_e$ )	35%	22%	3%
Light reflectance in full light spectrum ( $\rho_e$ )	59%	45%	53%
Light absorption in full light spectrum ( $\alpha_e$ )	6%	33%	44%
Openness factor	1	1	1

## Reaction to Fire

Norm	Class
EN 13501-1 + A1	B, s1-d0
DIN 4202-1	B1
NF P 92 503 -507	M1

## Roller blind effects on double-glazing unit (%)

Glazing variant	10L			11L			
	g-value	$\tau_v$ -value	Fc-value	g-value	$\tau_v$ -value	Fc-value	
Without RMM	61%	80%	100%	28%	52%	100%	
With RMM	White (8806)	36%	31%	59%	17%	21%	61%
	Grey (8805)	43%	8%	70%	22%	5%	79%
	Black (8807)	37%	0%	61%	18%	0%	64%

## Roller blind effects on double-glazing unit (%)

Glazing variant	10T			11T			12T			
	g-value	$\tau_v$ -value	Fc-value	g-value	$\tau_v$ -value	Fc-value	g-value	$\tau_v$ -value	Fc-value	
Without RMM	51%	73%	100%	28%	51%	100%	17%	18%	100%	
With RMM	White (8806)	30%	29%	59%	18%	19%	57%	13%	8%	76%
	Grey (8805)	37%	7%	73%	21%	5%	75%	14%	2%	82%
	Black (8807)	32%	0%	63%	17%	0%	61%	13%	0%	76%

Product name	VELUX VELUX®	Product code	10000000000000000000
Product description	VELUX VELUX®	Product description	VELUX VELUX®
Product type	VELUX VELUX®	Product type	VELUX VELUX®
Product category	VELUX VELUX®	Product category	VELUX VELUX®
Product version	VELUX VELUX®	Product version	VELUX VELUX®
Product status	VELUX VELUX®	Product status	VELUX VELUX®
Product date	VELUX VELUX®	Product date	VELUX VELUX®
Product location	VELUX VELUX®	Product location	VELUX VELUX®
Product manufacturer	VELUX VELUX®	Product manufacturer	VELUX VELUX®
Product distributor	VELUX VELUX®	Product distributor	VELUX VELUX®
Product retailer	VELUX VELUX®	Product retailer	VELUX VELUX®
Product supplier	VELUX VELUX®	Product supplier	VELUX VELUX®
Product contact	VELUX VELUX®	Product contact	VELUX VELUX®
Product website	VELUX VELUX®	Product website	VELUX VELUX®
Product email	VELUX VELUX®	Product email	VELUX VELUX®
Product phone	VELUX VELUX®	Product phone	VELUX VELUX®
Product fax	VELUX VELUX®	Product fax	VELUX VELUX®
Product address	VELUX VELUX®	Product address	VELUX VELUX®
Product city	VELUX VELUX®	Product city	VELUX VELUX®
Product country	VELUX VELUX®	Product country	VELUX VELUX®
Product postal code	VELUX VELUX®	Product postal code	VELUX VELUX®

## Roller blind



### Roller blind effects on triple-glazing unit (%)

Glazing variant		16L			17L		
		g-value	$\tau_v$ -value	F <sub>c</sub> -value	g-value	$\tau_v$ -value	F <sub>c</sub> -value
Without RMM		52%	72%	100%	25%	46%	100%
With RMM	White (8806)	32%	28%	62%	16%	18%	64%
	Grey (8805)	39%	7%	75%	20%	5%	80%
	Black (8807)	34%	0%	65%	17%	0%	68%

### Roller blind effects on triple-glazing unit (%)

Glazing variant		16T / 16K			17T / 17K			18T		
		g-value	$\tau_v$ -value	F <sub>c</sub> -value	g-value	$\tau_v$ -value	F <sub>c</sub> -value	g-value	$\tau_v$ -value	F <sub>c</sub> -value
Without RMM		49%	70%	100%	24%	45%	100%	14%	16%	100%
With RMM	White (8806)	30%	28%	61%	15%	18%	63%	11%	7%	79%
	Grey (8805)	37%	7%	76%	19%	5%	79%	13%	2%	93%
	Black (8807)	32%	0%	65%	16%	0%	67%	12%	0%	86%

#### g-value:

"The total transmitted fraction of the incident solar radiation consisting of direct transmitted solar radiation and the part of the absorbed solar radiation transferred by convection and thermal radiation to the internal environment." (EN 13363-2)

"The fraction of the incident solar radiation that is totally transmitted by the glass." (EN 410)

The g-value (total solar energy transmittance) is a measure of how much solar energy is transmitted through the construction in the cooling period.

The g-value is defined as the ratio between the solar energy transmitted through the glazing and the incident solar factor on the glazing.

#### $\tau_v$ -value:

"The transmitted fraction of the incident solar radiation in the visible part of the solar spectrum, see EN 410." (EN 13363-2)

"The fraction of incident light that is transmitted by the glass." (EN 410)

#### F<sub>c</sub>-value:

"The shading factor, F<sub>c</sub>-value, is the ratio of the solar factor of the combined glazing and solar protection device, g<sub>tot</sub>, to that of the glazing alone, g. F<sub>c</sub>=g<sub>tot</sub>/g.

Note: in some countries, F<sub>c</sub> is known as z." (EN 14501)

## Beam for Ridgelight at 5°



Beam for Ridgelight at 5°		
	Horizontal beam with rectangular profile	Parallel beam with curved profile
Material	Steel	Steel
Material thickness	3 mm	4 mm
Construction	Hollow beam	Hollow beam
Surface	Powder coating, white RAL 9010, gloss 30	Powder coating, white RAL 9010, gloss 30
Foam gasket on beam	Grey 15 mm	Black 6 mm

### Horizontal beam with rectangular profile

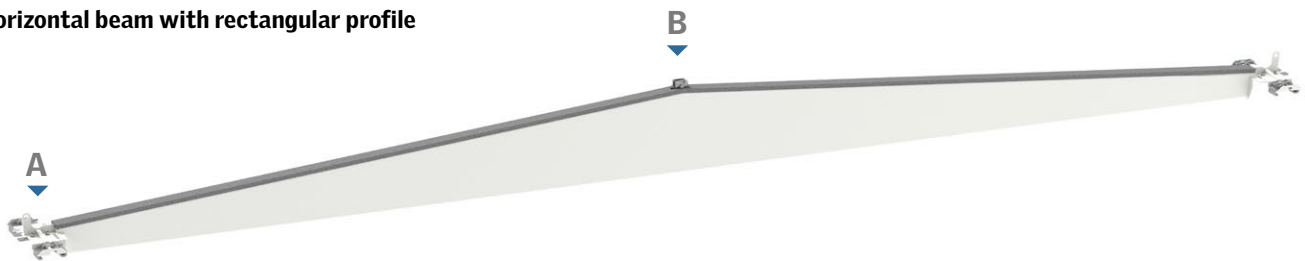

### Parallel beam with curved profile

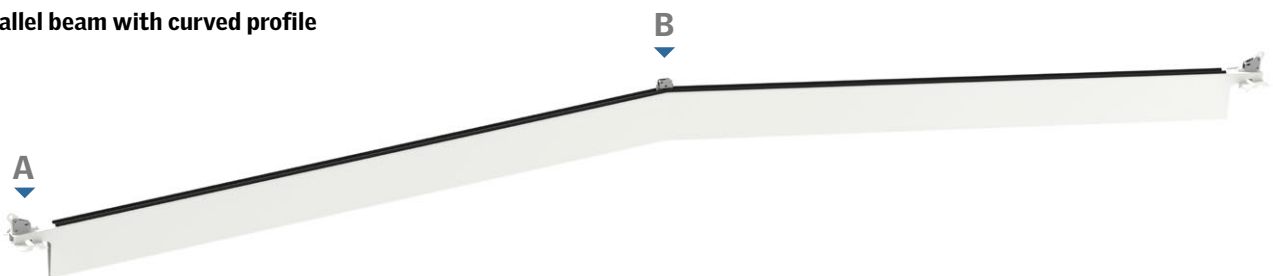

Product	Material	Weight	Dimensions
VELUX L1000	Alu	12.5 kg	1000 x 1000 x 100
VELUX L1500	Alu	18.5 kg	1500 x 1000 x 100
VELUX L2000	Alu	24.5 kg	2000 x 1000 x 100
VELUX L2500	Alu	30.5 kg	2500 x 1000 x 100
VELUX L3000	Alu	36.5 kg	3000 x 1000 x 100
VELUX L3500	Alu	42.5 kg	3500 x 1000 x 100
VELUX L4000	Alu	48.5 kg	4000 x 1000 x 100
VELUX L4500	Alu	54.5 kg	4500 x 1000 x 100
VELUX L5000	Alu	60.5 kg	5000 x 1000 x 100
VELUX L5500	Alu	66.5 kg	5500 x 1000 x 100
VELUX L6000	Alu	72.5 kg	6000 x 1000 x 100
VELUX L6500	Alu	78.5 kg	6500 x 1000 x 100
VELUX L7000	Alu	84.5 kg	7000 x 1000 x 100
VELUX L7500	Alu	90.5 kg	7500 x 1000 x 100
VELUX L8000	Alu	96.5 kg	8000 x 1000 x 100
VELUX L8500	Alu	102.5 kg	8500 x 1000 x 100
VELUX L9000	Alu	108.5 kg	9000 x 1000 x 100
VELUX L9500	Alu	114.5 kg	9500 x 1000 x 100
VELUX L10000	Alu	120.5 kg	10000 x 1000 x 100

## Water pressure & drainage



### Additional information on water pressure and drainage on a Step Wall-mounted Longlight

Please note that the same installation pitch is required on all rows and the maximum distance from the top of the vertical wall to the top of the lowest row of modules is 15 metres.

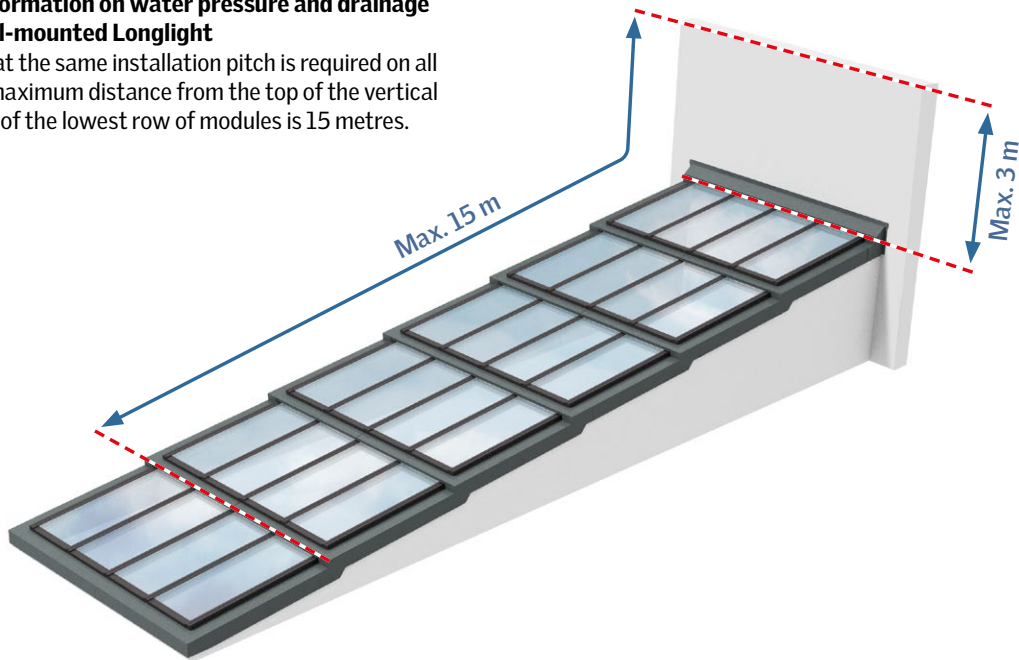

### Additional information on water pressure and drainage on a Northlight

Please ensure max. 10 m distance above the skylight module, when installed in a sloping roof.

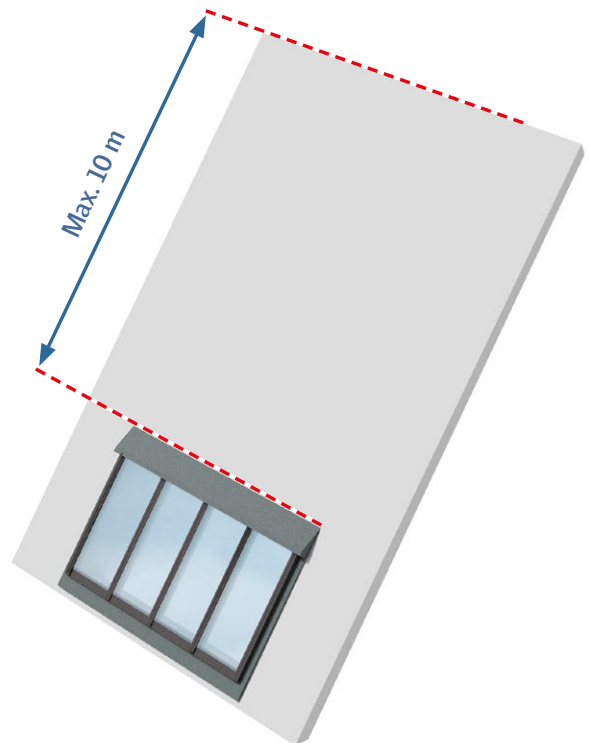

### Additional information on water pressure and drainage on a Wall-mounted Longlight

Please ensure a max. 3 m wall height above skylight module.



# Resistance to wind load

Test method: EN 12211

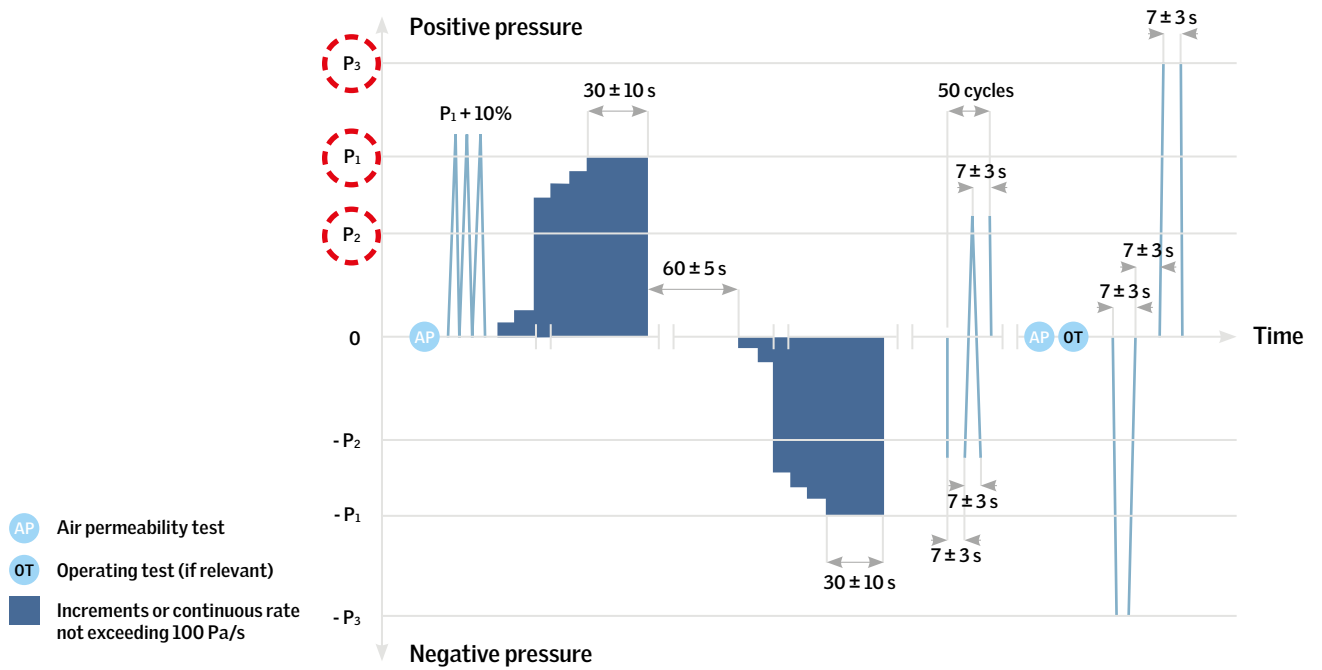

- P<sub>3</sub> **VELUX Modular Skylights: Class C5 \***
- P<sub>1</sub> : 2000 Pa
- P<sub>2</sub> : 1000 Pa
- P<sub>3</sub> : 3000 Pa

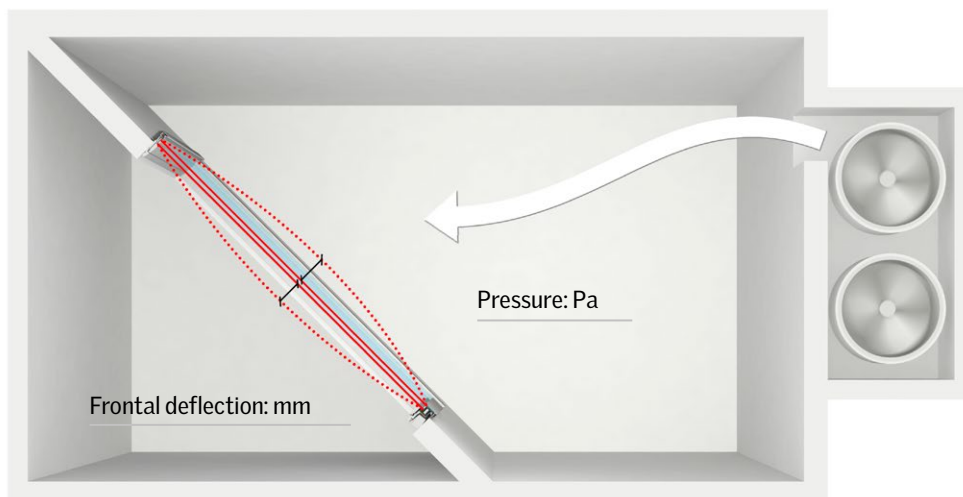

\* Valid for sizes up to 1000 mm width and up to 2400 mm height, except HVC 090220, HVC 090240, HVC 100220 and HVC 100240 with glazing variants 10L and 11L, which have Class C4. Above these sizes the applicable performance is NPD.





# Reaction to fire



Test method: EN ISO 11925-2, EN 13823

Reaction to fire classes for building products (excl. floorings)							
Main class	Smoke class	Burning droplets class	Requirements according to			FIGRA	
			Non comb	SBI	Small flame	W/s	
A1	-	-	x	-	-	-	Non combustible
A2	s1 - s3	d0 - d2	x	x	-	≤ 120	
<b>B</b>	s1 - s3	d0 - d2	-	x	x	≤ 120	
C	s1 - s3	d0 - d2	-	x	x	≤ 250	
D	s1 - s3	d0 - d2	-	x	x	≤ 750	
E	-	- or d2	-	-	x	-	
F	-	-	-	-	-	-	No performance determined

<sup>1)</sup> The test is a corner basket test, which shows how much the product contributes to the development of fire.

Internal fire spread and smoke contribution.

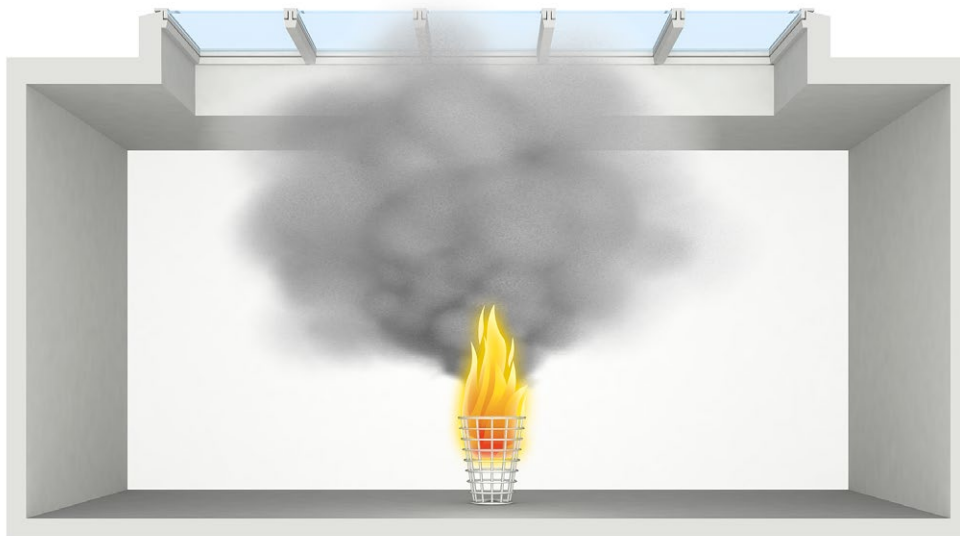

Product Name	Product Code	Product Description	Product Dimensions
VELUX Modular Skylight	050000000	0.5m x 0.5m x 0.075m	0.5m x 0.5m
VELUX Modular Skylight	050000001	0.75m x 0.75m x 0.075m	0.75m x 0.75m
VELUX Modular Skylight	050000002	1.0m x 1.0m x 0.075m	1.0m x 1.0m
VELUX Modular Skylight	050000003	1.25m x 1.25m x 0.075m	1.25m x 1.25m
VELUX Modular Skylight	050000004	1.5m x 1.5m x 0.075m	1.5m x 1.5m
VELUX Modular Skylight	050000005	1.75m x 1.75m x 0.075m	1.75m x 1.75m
VELUX Modular Skylight	050000006	2.0m x 2.0m x 0.075m	2.0m x 2.0m
VELUX Modular Skylight	050000007	2.25m x 2.25m x 0.075m	2.25m x 2.25m
VELUX Modular Skylight	050000008	2.5m x 2.5m x 0.075m	2.5m x 2.5m
VELUX Modular Skylight	050000009	2.75m x 2.75m x 0.075m	2.75m x 2.75m
VELUX Modular Skylight	050000010	3.0m x 3.0m x 0.075m	3.0m x 3.0m



## Reaction to fire

Classification: EN 13501-1 + A1

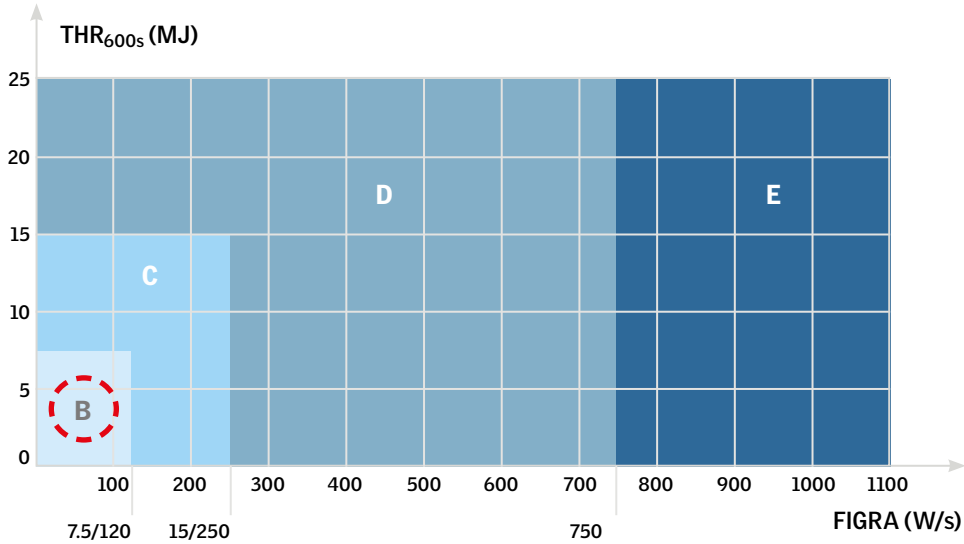

## Smoke sub-class

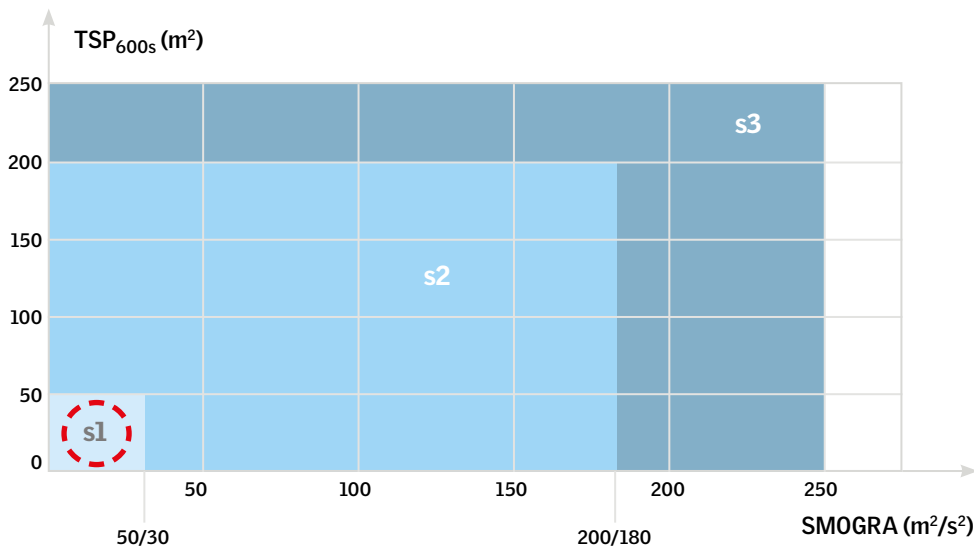

### CLASSIFICATION

- A1, A2, B: Non-combustable and not very combustible product. Over 20 minutes to flashover.
- C: Moderate combustible products. Between 10 and 20 minutes to flashover.
- D: Moderate combustible products. Between 2 and 10 minutes to flashover.
- E: Moderate combustible products.
- F: Highly combustible products (or products whose reaction to fire has not been assessed).

### SUB-CLASS

- s1: Low smoke production.
- s2: Medium smoke production.
- s3: High smoke production.

### FLAMING DROPLETS SUB-CLASSIFICATION

- d0: No flaming droplets.
- d1: Flaming droplets that persist for less than 10 s.
- d2: Flaming droplets.



### VELUX Modular Skylights:

#### Class B, s1-d0 or d2

B: Very low combustibility

(A: Incumbustable eg steel and concrete)

s1: Lowest smoke volume

d0: No droplets in T-pane variants

d2: Droplets in standard pane variant

# Resistance to fire



**Test method: EN 1365-2**

**Fixed modules:** EN 1365-2 Fire resistance tests for loadbearing elements - Part 2: Floors and roofs\*

\* In accordance with EN 1365-2, 1, which is the relevant standard for fixed modular skylights, roofs can be roof constructions incorporating glazed elements.

Under fire conditions, certain elements and windows can be required to remain satisfactory fire barriers depending on national and local requirements.

The tests assess how satisfactory fire barriers the modules are in the defined test conditions.

More simply, the tests assess the length of time the modules can effectively keep the fire inside the burning compartment.

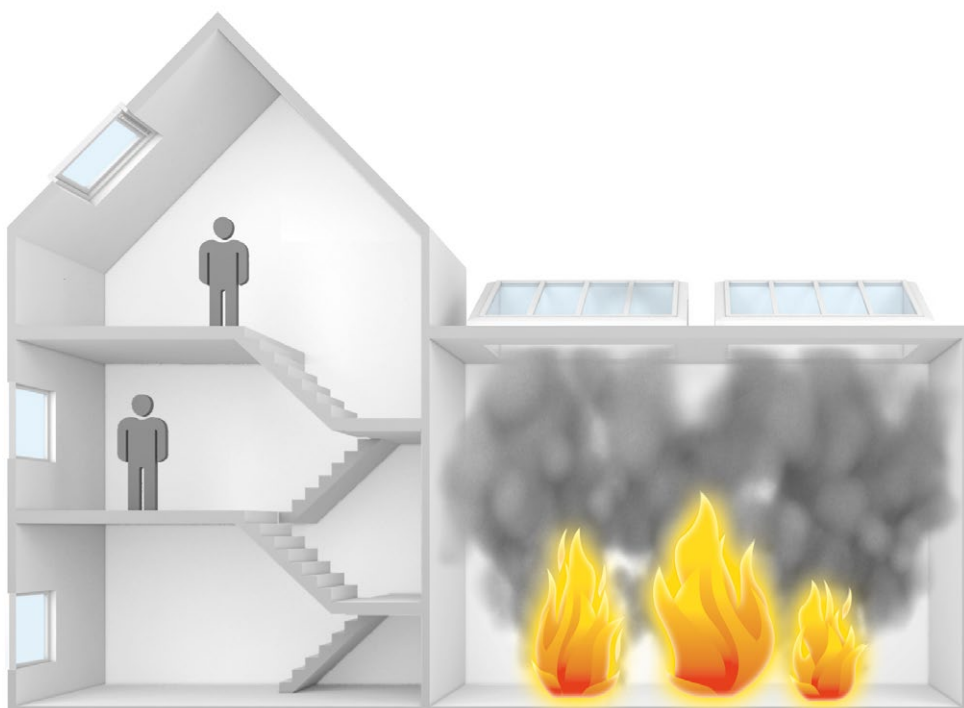

Temperature in the furnace

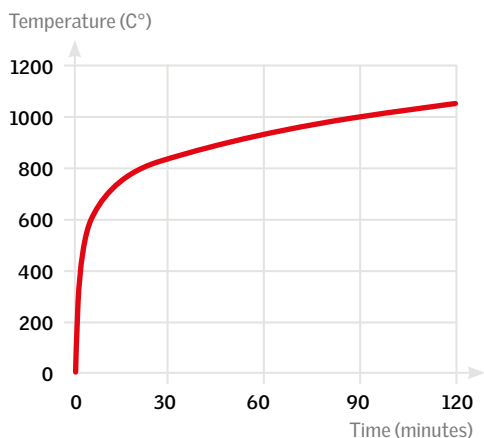

Modules on the furnace



Product name	VELUX Modular Skylight	Accessories	VELUX Modular Skylight
Product code	0500000000	Accessories code	0500000000
Product description	VELUX Modular Skylight	Accessories description	VELUX Modular Skylight
Product category	VELUX Modular Skylight	Accessories category	VELUX Modular Skylight
Product type	VELUX Modular Skylight	Accessories type	VELUX Modular Skylight
Product status	VELUX Modular Skylight	Accessories status	VELUX Modular Skylight
Product version	VELUX Modular Skylight	Accessories version	VELUX Modular Skylight
Product date	VELUX Modular Skylight	Accessories date	VELUX Modular Skylight
Product manufacturer	VELUX Modular Skylight	Accessories manufacturer	VELUX Modular Skylight
Product country of origin	VELUX Modular Skylight	Accessories country of origin	VELUX Modular Skylight
Product weight	VELUX Modular Skylight	Accessories weight	VELUX Modular Skylight
Product dimensions	VELUX Modular Skylight	Accessories dimensions	VELUX Modular Skylight
Product material	VELUX Modular Skylight	Accessories material	VELUX Modular Skylight
Product color	VELUX Modular Skylight	Accessories color	VELUX Modular Skylight
Product finish	VELUX Modular Skylight	Accessories finish	VELUX Modular Skylight
Product warranty	VELUX Modular Skylight	Accessories warranty	VELUX Modular Skylight
Product safety	VELUX Modular Skylight	Accessories safety	VELUX Modular Skylight
Product compliance	VELUX Modular Skylight	Accessories compliance	VELUX Modular Skylight
Product certification	VELUX Modular Skylight	Accessories certification	VELUX Modular Skylight
Product testing	VELUX Modular Skylight	Accessories testing	VELUX Modular Skylight
Product installation	VELUX Modular Skylight	Accessories installation	VELUX Modular Skylight
Product maintenance	VELUX Modular Skylight	Accessories maintenance	VELUX Modular Skylight
Product disposal	VELUX Modular Skylight	Accessories disposal	VELUX Modular Skylight



## Resistance to fire

**Classification: EN 13501-2 + A1**

### Presentation of classification

Performance Characteristics – Designatory letters and pass criteria  
The classification shall be presented according to the following template

Presentation of classification		
Load bearing capacity	Integrity	Insulation
R	E	I

**R- Load bearing capacity** (not applicable on venting modules, only on fixed)  
Withstanding fire exposure without loss of mechanical stability

### E- Integrity

No cracks or openings in excess of given dimension  
No ignition of a cotton pad on the unexposed side  
No flames sustained on the unexposed side

### I- Insulation

Maximum temperature rise on unexposed side not exceeding 180°  
Mean temperature rise on unexposed side not exceeding 140°C

Please note that there are further characteristics that are defined in the standard, however these are not relevant for VELUX Modular Skylights.

### Classification periods

All classification periods against any of the characteristics must be declared in minutes, using one of the periods: 10, 15, 20, 30, 45, 60, 90, 120, 180, 240 or 360. Note that not all the periods apply to all elements.

### Declaration of performance

Combination of the designatory letters as appropriate shall be used as a part of the classification of performance. They shall be supplemented by time in the elapsed completed minutes of the nearest lowest class during which the functional requirements are satisfied.

### VELUX Modular Skylights:

Fixed module (HFS):



For more information on fire resistant skylight module HFS, see pages 80 and 100.

# External fire performance



## Test method: TS 1187 - External fire exposure to roofs\*

\* In accordance with EN 14351-1, TS1187 test methods T1 and T4 must be used to determine the external fire performance of roof windows.

The tests assess the fire spread across the external surface of the roof\*, the fire spread within the roof\*, the fire penetration and the production of falling droplets or debris falling from the underside of the roof\*.

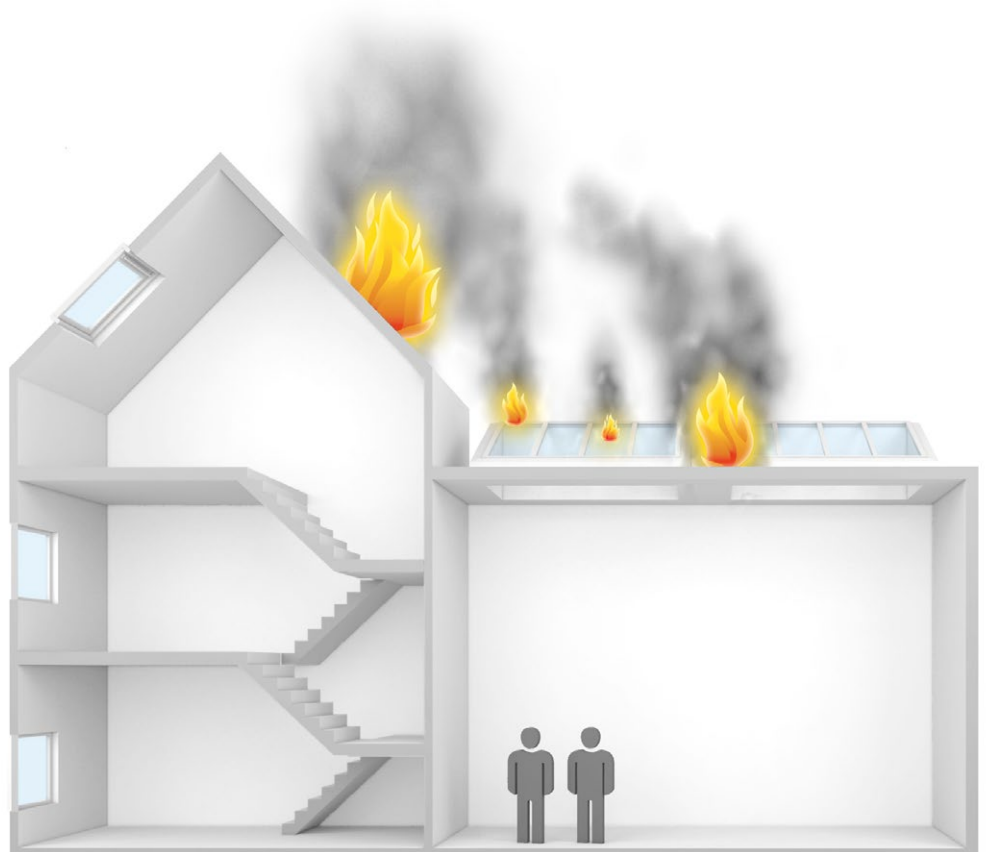

Test 1 – with burning brands

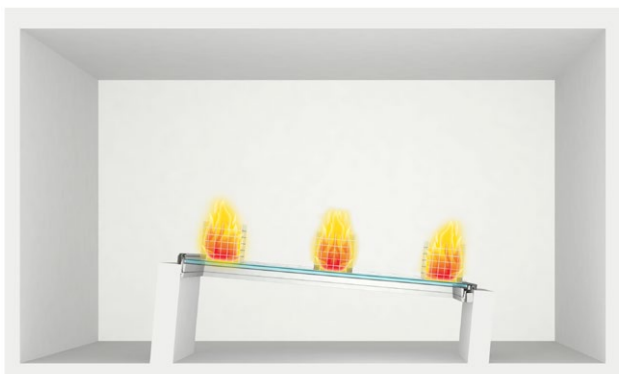

Test 4 - two stages incorporating burning brands, wind and supplementary radiant heat

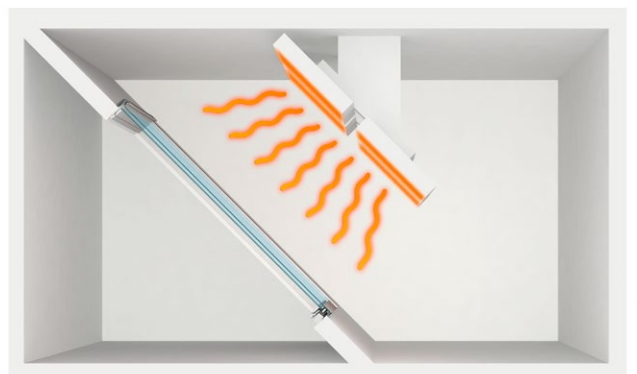



Product name	VELUX Modular Skylights	Product code	00000000000000000000
Product description	VELUX Modular Skylights	Product code	00000000000000000000
Product description	VELUX Modular Skylights	Product code	00000000000000000000
Product description	VELUX Modular Skylights	Product code	00000000000000000000
Product description	VELUX Modular Skylights	Product code	00000000000000000000
Product description	VELUX Modular Skylights	Product code	00000000000000000000
Product description	VELUX Modular Skylights	Product code	00000000000000000000
Product description	VELUX Modular Skylights	Product code	00000000000000000000
Product description	VELUX Modular Skylights	Product code	00000000000000000000
Product description	VELUX Modular Skylights	Product code	00000000000000000000



## External fire performance

Classification: EN 13501-5 + A1

### Test 1

Class	Classification criteria
<b>B<sub>ROOF</sub> (t1)</b>	<p>All of the following conditions must be satisfied for all tests:</p> <ul style="list-style-type: none"> <li>external and internal fire spread upwards &lt; 0.700 m</li> <li>external and internal fire spread downwards &lt; 0.600 m</li> <li>maximum burned length external and internal &lt; 0.800 m</li> <li>no burning material (droplets or debris) falling from exposed side</li> <li>no burning/glowing particles penetrate the roof construction</li> <li>no single through opening &gt; 25 mm<sup>2</sup></li> <li>sum of all spread opening &lt; 4500 mm<sup>2</sup></li> <li>lateral fire spread does not reach the edges of the measuring zone</li> <li>no internal glowing combustion</li> <li>maximum radius of fire spread on flat roofs, external and internal &lt; 0.200 m</li> </ul>
F <sub>ROOF</sub> (t1)	No performance determined.

### Test 4

Class	Classification criteria
<b>B<sub>ROOF</sub> (t4)</b>	<ul style="list-style-type: none"> <li>No penetration of roof system within 1 h.</li> <li>In preliminary test, after withdrawal of the test flame, specimens burn for &lt; 5 min.</li> <li>In preliminary test, flame spread &lt; 0.38 m across region of burning.</li> </ul>
C <sub>ROOF</sub> (t4)	<ul style="list-style-type: none"> <li>No penetration of roof system within 30 min.</li> <li>In preliminary test, after withdrawal of the test flame, specimens burn for &lt; 5 min.</li> <li>In preliminary test, flame spread &lt; 0.38 m across region of burning.</li> </ul>
D <sub>ROOF</sub> (t4)	<ul style="list-style-type: none"> <li>Roof system is penetrated within 30 min but is not penetrated in the preliminary test.</li> <li>In preliminary test, after withdrawal of the test flame, specimens burn for &lt; 5 min.</li> <li>In preliminary test, flame spread &lt; 0.38 m across region of burning.</li> </ul>
E <sub>ROOF</sub> (t4)	<ul style="list-style-type: none"> <li>Roof system is penetrated within 30 min but is not penetrated in the preliminary test.</li> <li>Flame spread is not controlled.</li> </ul>
F <sub>ROOF</sub> (t1)	No performance determined.



VELUX Modular Skylights

B<sub>ROOF</sub> (t1)

B<sub>ROOF</sub> (t4)

# Watertightness

Test method: EN 1027

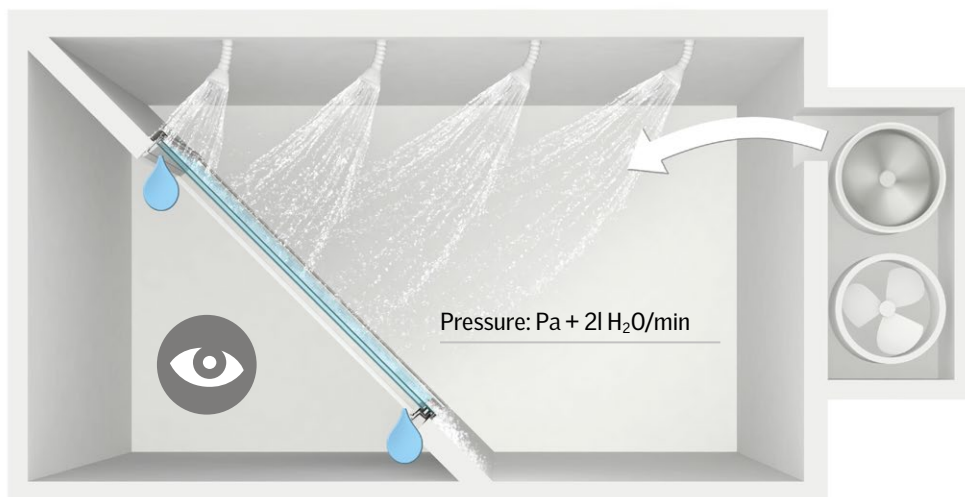
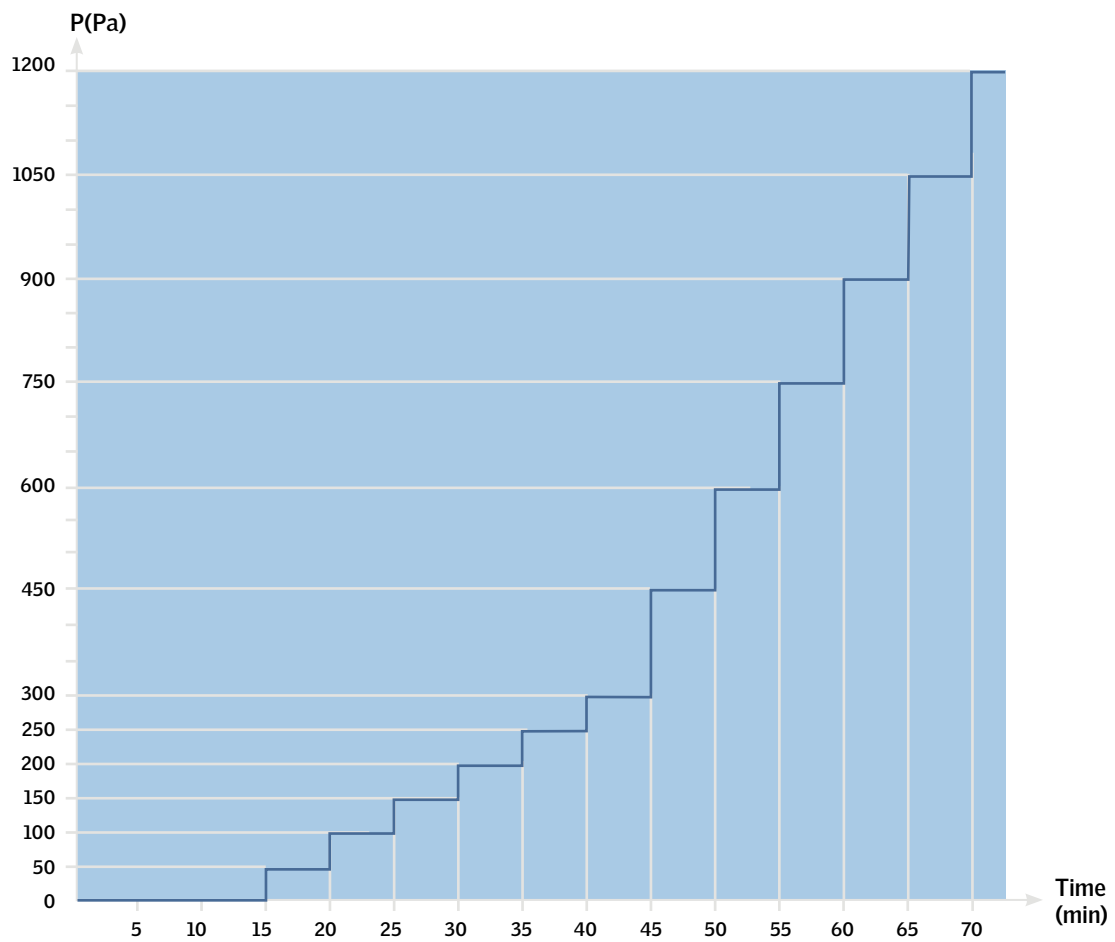

Product Name	VELUX Skylight	Model	SKL 1000
Material	Aluminum	Color	Black
Weight	15 kg	Dimensions (L x W x H)	1000 x 1000 x 100 mm
Installation	Standard	Warranty	5 Years



## Watertightness

Classification: EN 12208

Watertightness		
Classification	Pressure (Pa)	Wind (Km/h)
1 A	0	0
2 A	50	32
3 A	100	45
4 A	150	55*
5 A	200	63
6 A	250	71
7 A	300	78
8 A	450	95
9 A	600	110
E750	750	123**
E900	900	134
E1050	1050	145
<b>E1200</b>	<b>1200</b>	<b>155</b>

\* Equal to depression

\*\* Equal to tropical storm



### VELUX Modular Skylights: E1200

No water penetration up to 1200 Pa.  
1200 Pa equals 155 Km/h.

# Air permeability

Test method: EN 1026

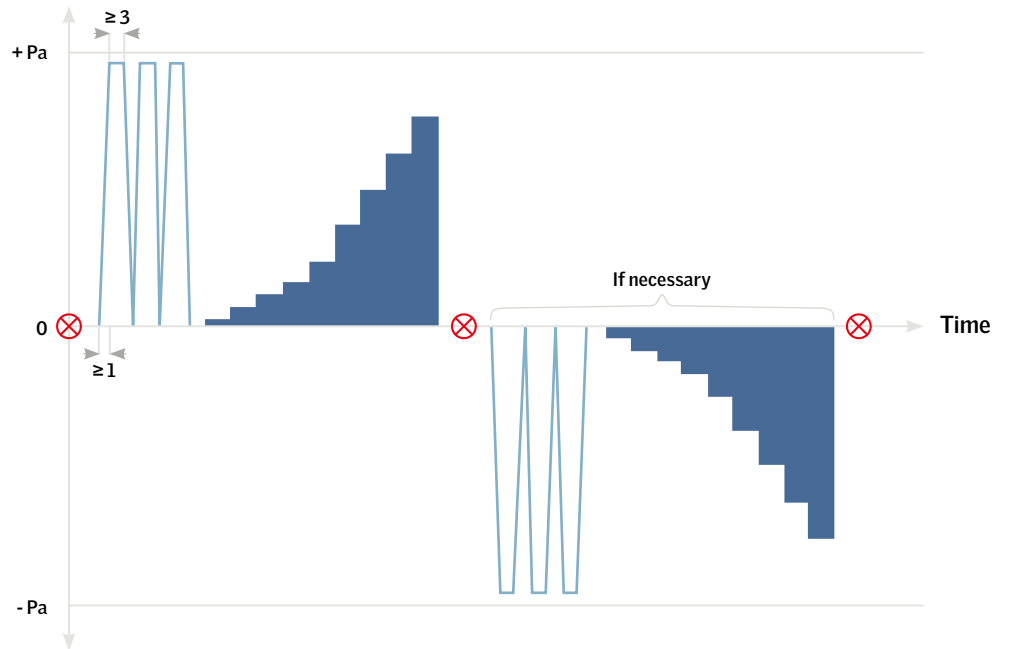

## Test pressure

- 150 Pa - Class 1
- 300 Pa - Class 2
- 600 Pa - Class 3, 4

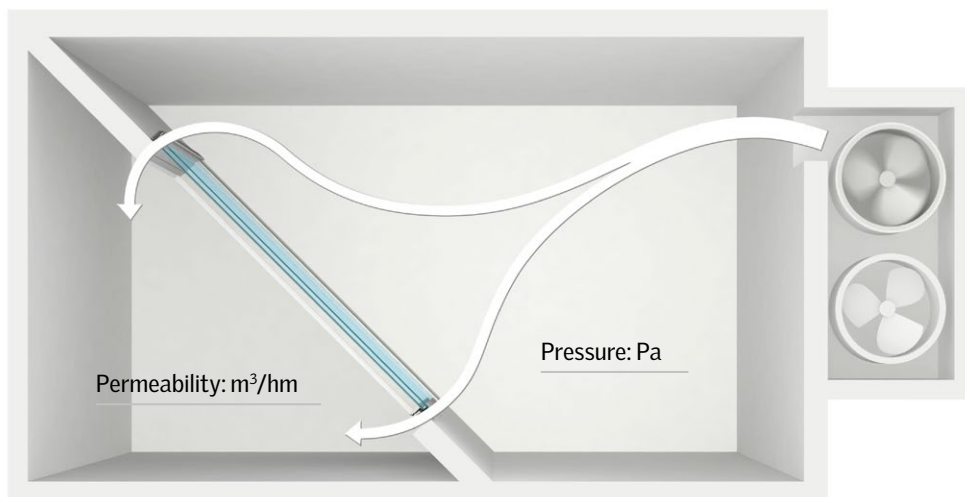

Product	Accessories	Accessories	Accessories
VELUX Modular Skylights	VELUX Skylight Mounting Brackets	VELUX Skylight Mounting Brackets	VELUX Skylight Mounting Brackets
VELUX Modular Skylights	VELUX Skylight Mounting Brackets	VELUX Skylight Mounting Brackets	VELUX Skylight Mounting Brackets
VELUX Modular Skylights	VELUX Skylight Mounting Brackets	VELUX Skylight Mounting Brackets	VELUX Skylight Mounting Brackets
VELUX Modular Skylights	VELUX Skylight Mounting Brackets	VELUX Skylight Mounting Brackets	VELUX Skylight Mounting Brackets
VELUX Modular Skylights	VELUX Skylight Mounting Brackets	VELUX Skylight Mounting Brackets	VELUX Skylight Mounting Brackets
VELUX Modular Skylights	VELUX Skylight Mounting Brackets	VELUX Skylight Mounting Brackets	VELUX Skylight Mounting Brackets
VELUX Modular Skylights	VELUX Skylight Mounting Brackets	VELUX Skylight Mounting Brackets	VELUX Skylight Mounting Brackets
VELUX Modular Skylights	VELUX Skylight Mounting Brackets	VELUX Skylight Mounting Brackets	VELUX Skylight Mounting Brackets
VELUX Modular Skylights	VELUX Skylight Mounting Brackets	VELUX Skylight Mounting Brackets	VELUX Skylight Mounting Brackets
VELUX Modular Skylights	VELUX Skylight Mounting Brackets	VELUX Skylight Mounting Brackets	VELUX Skylight Mounting Brackets



## Air permeability

Classification: EN 12207

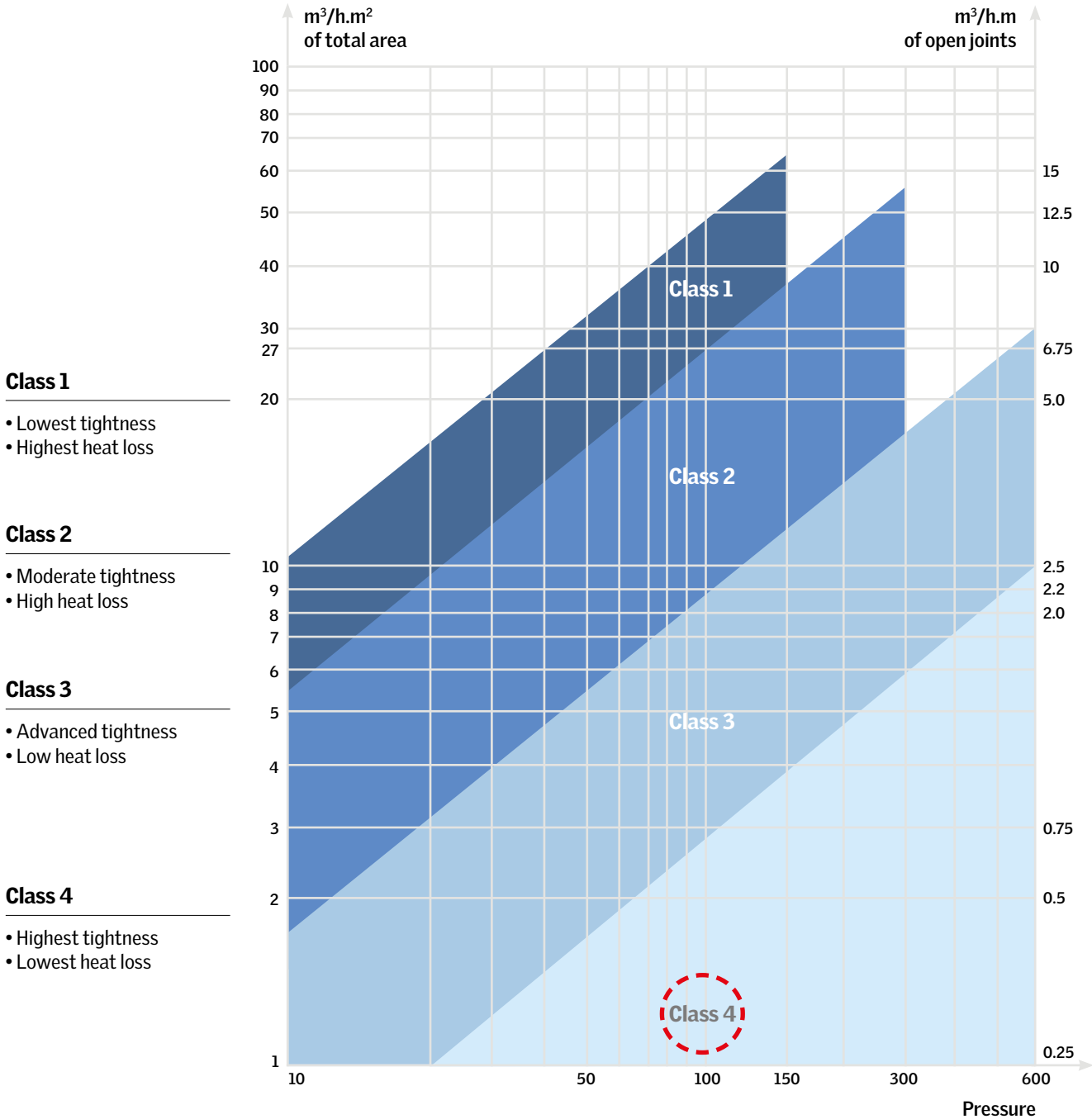

### Class 1

- Lowest tightness
- Highest heat loss

### Class 2

- Moderate tightness
- High heat loss

### Class 3

- Advanced tightness
- Low heat loss

### Class 4

- Highest tightness
- Lowest heat loss

 **VELUX Modular Skylights: Class 4**





The background features a complex, layered architectural drawing. It consists of multiple overlapping rectangular frames defined by thin white lines. These frames are arranged in a perspective that recedes into the distance. Superimposed on these white lines are several thick, vibrant blue curved lines that sweep across the composition, adding a sense of movement and depth. The overall aesthetic is clean, technical, and modern.

# Additional Solutions

The following shown solutions for other types of skylight projects is project specific

## Shaped solution with adaption of lining

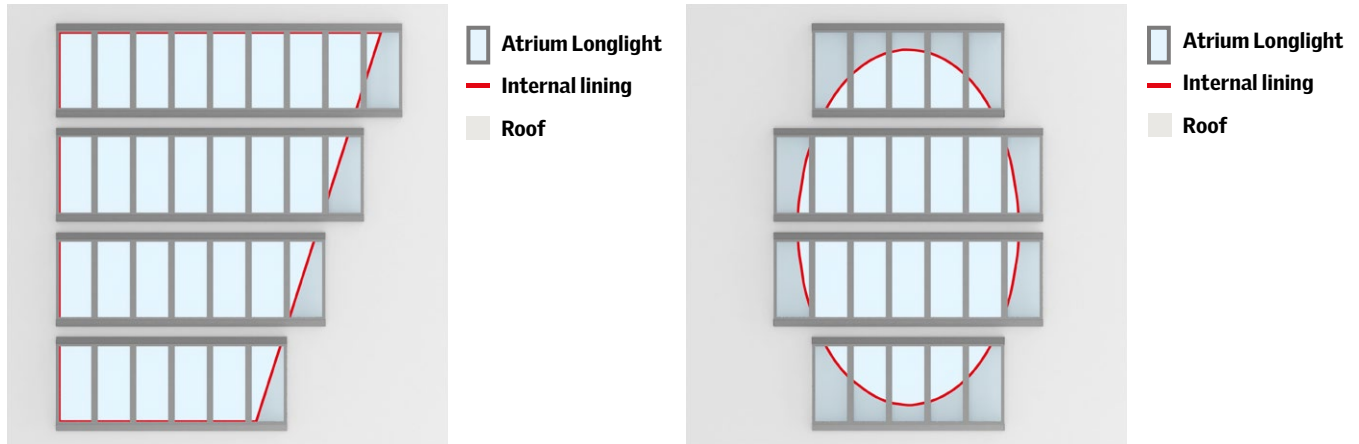

Feature	Advantage	Benefit
By adapting the internal lining, it is possible to build a shaped skylight with standard skylight modules. *	By using standard skylight modules on non-square roof designs, the architects will not have to compromise the wishes for the interior design. The solution can be combined with venting modules and internal roller blinds.	Using standard products with standard installation principles gives high security in the design and building process. Installing venting modules and roller blinds gives a better indoor climate.

\* If the modules are fitted with RMM, access from outside is mandatory.

## Shaped solution with oval lining

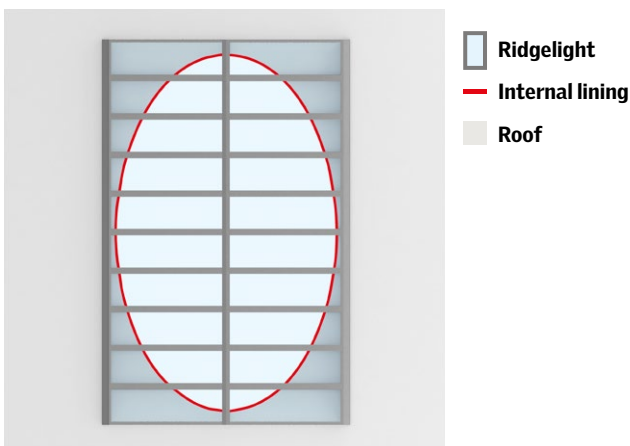

Feature	Advantage	Benefit
By adapting the internal lining, it is possible to build a shaped skylight with standard skylight modules. *	By using standard skylight modules on non-square roof designs, the architects will not have to compromise the wishes for the interior design.	Using standard products with standard installation principles gives high security in the design and building process. The solution can be combined with internal roller blinds.

\* If the modules are fitted with RMM, access from outside is mandatory.

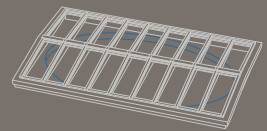

## Asymmetric Ridgelight

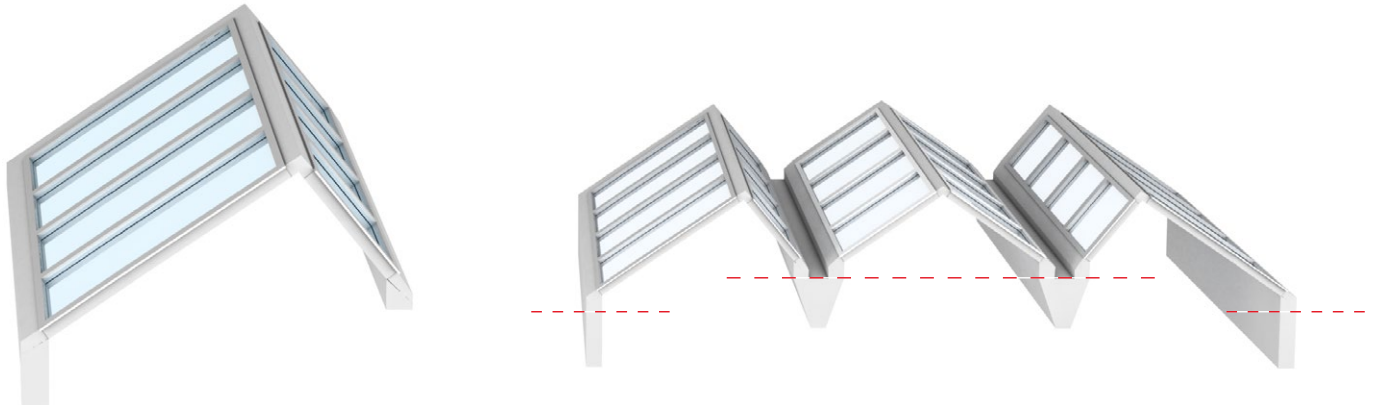

Feature	Advantage	Benefit
By constructing an asymmetric Ridgelight, it is possible to combine modules of different lengths in an installation.	The solution allows for installation between two roofs of different heights or of modules in different slopes. By combining panes with different characteristics on each side of the Ridgelight, it is possible to maximize daylight and minimize heat gain.	The asymmetric Ridgelight offers more flexibility in installations between buildings or sections of buildings.

## Ridgelight on Girder

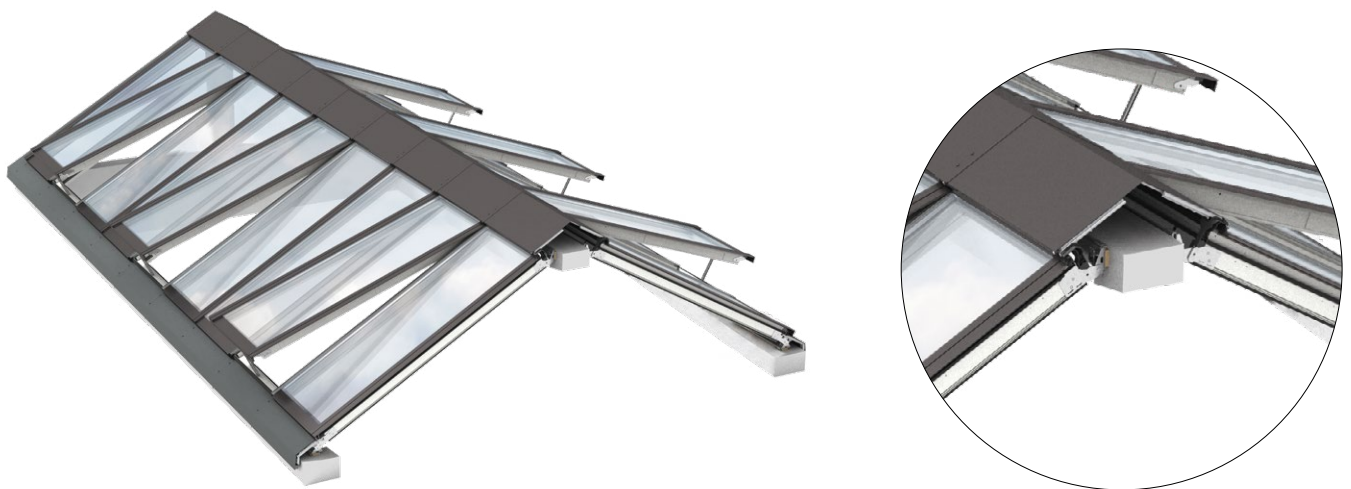

Feature	Advantage	Benefit
A Ridgelight solution that consists of two rows of VELUX Modular Skylights installed on one supporting horizontal girder at the ridge. The solution is delivered with a factory finished flashing designed for installation in pitches between 5-40°, either on a flat roof construction or at the top of a sloped roof. Girder and inner girder cover is not part of VELUX delivery.	<ul style="list-style-type: none"> <li>The girder supports the installation and thus allows for increased installation pitch possibilities of the modules.</li> <li>Possibilities of vented modules on both sides.</li> <li>Possibilities of different glazing types on each side.</li> </ul>	<ul style="list-style-type: none"> <li>Additional design options.</li> <li>Low pitch allows maximum daylight in the room.</li> <li>The large opening gives an illusion of a small glass roof.</li> </ul>

# Infill panel

Ventilation penetration

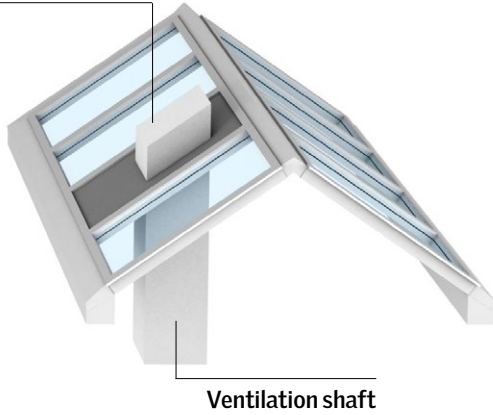

Infill panel

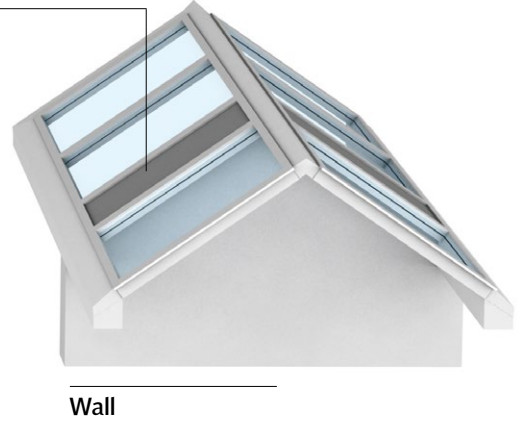

Feature	Advantage	Benefit
<p>Ventilation shaft: Use an infill panel when penetrating the skylight with e.g. ventilation.</p> <p>Wall: Use infill panels when covering a wall in the building.</p>	<p>Continuous modular skylight installations instead of disrupted installations.</p>	<p>Cheaper product solution and better design.</p>

**Note:**  
 Products with a fixed, opaque insulating infill panel are out of the scope of the harmonised product standard EN 14351-1 used for CE marking of windows. No harmonised product standard is available/applicable for these products; they are not and cannot be CE-marked. The VELUX Group can deliver the above-mentioned products and provide product specifications on the relevant general performance characteristics for thermal transmittance, air permeability, watertightness, resistance to wind load and reaction to fire on request. The VELUX Group is not responsible for the specific application of the product with fixed, opaque insulating infill panel. It is the responsibility of the customer to verify the fitness of the product for specific use with the relevant authorities.

# Skylight modules with photovoltaic glazing units

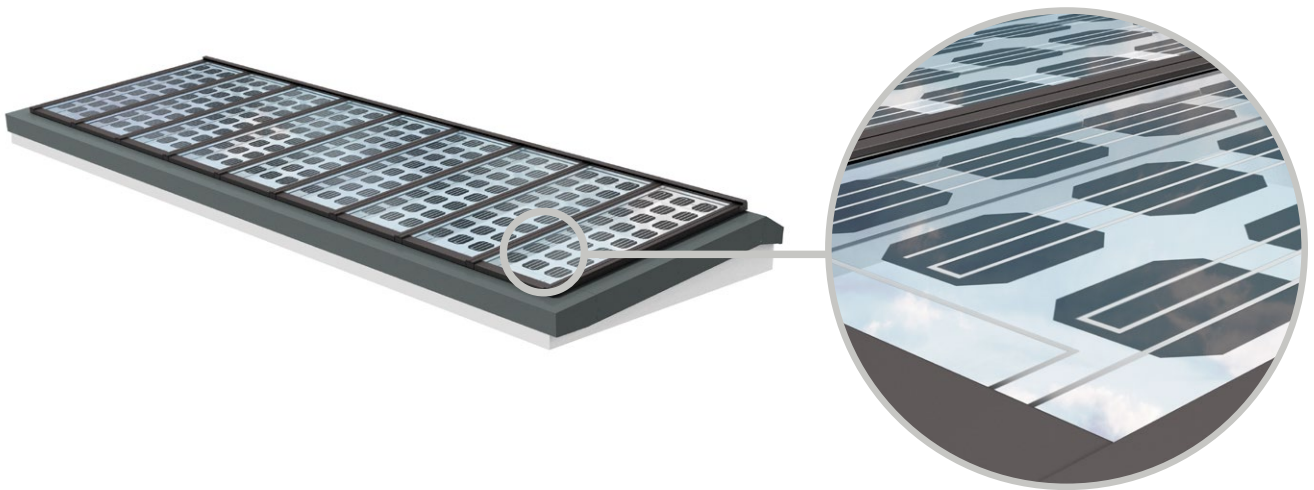

Feature	Advantage	Benefit
<p>VELUX Modular Skylights can be delivered with photovoltaic glazing units in both a fully covered or partly covered variant (illustration shows partly covered variant).</p>	<p>The solution offers a built-in solution where photovoltaic panels are combined with skylight installations.</p>	<p>The solution will optimize the utilization of space on the roof. Furthermore, the photovoltaic panels create a shadow effect in the building that reduces heat gain and glare.</p>

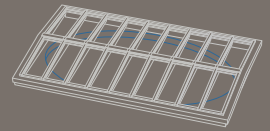

## Sun screening – electrochrome glass



Glazing with electrochrome glass in clear state. Visible light transmission 57%



Glazing with electrochrome glass in intermediate state. Visible light transmission 15%

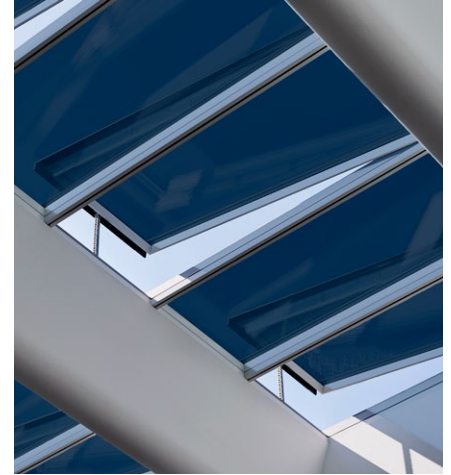

Glazing with electrochrome glass in fully tinted state. Visible light transmission 1%

VELUX Modular Skylights are available with electrochromic panes. The electrochromic pane is an insulated glazing unit with electronic, tintable coating. The coating can be darkened on demand by applying a low voltage of electricity. The dynamic changing in tint provides exceptional control of daylight, glare and energy use

without blinds or shades. An easy-to-use control system allows anyone to operate the electrochromic panes with wall switches, a mobile app or with a building management system. A combination of the three is also possible.

## Sun screening – external awning blinds

### Maintain a pleasant thermal indoor environment

The Topfix® VMS external awning blind by Renson protects the interior from excessive solar heating. The product is optimized for VELUX Modular Skylights and is applicable to both fixed and vent-

ing modules. Topfix® VMS operates on mounting feet that fits perfectly onto the external surface of the modular profiles. The blinds features a VELUX compatible operation system and can endure wind loads up to 120 km/h.





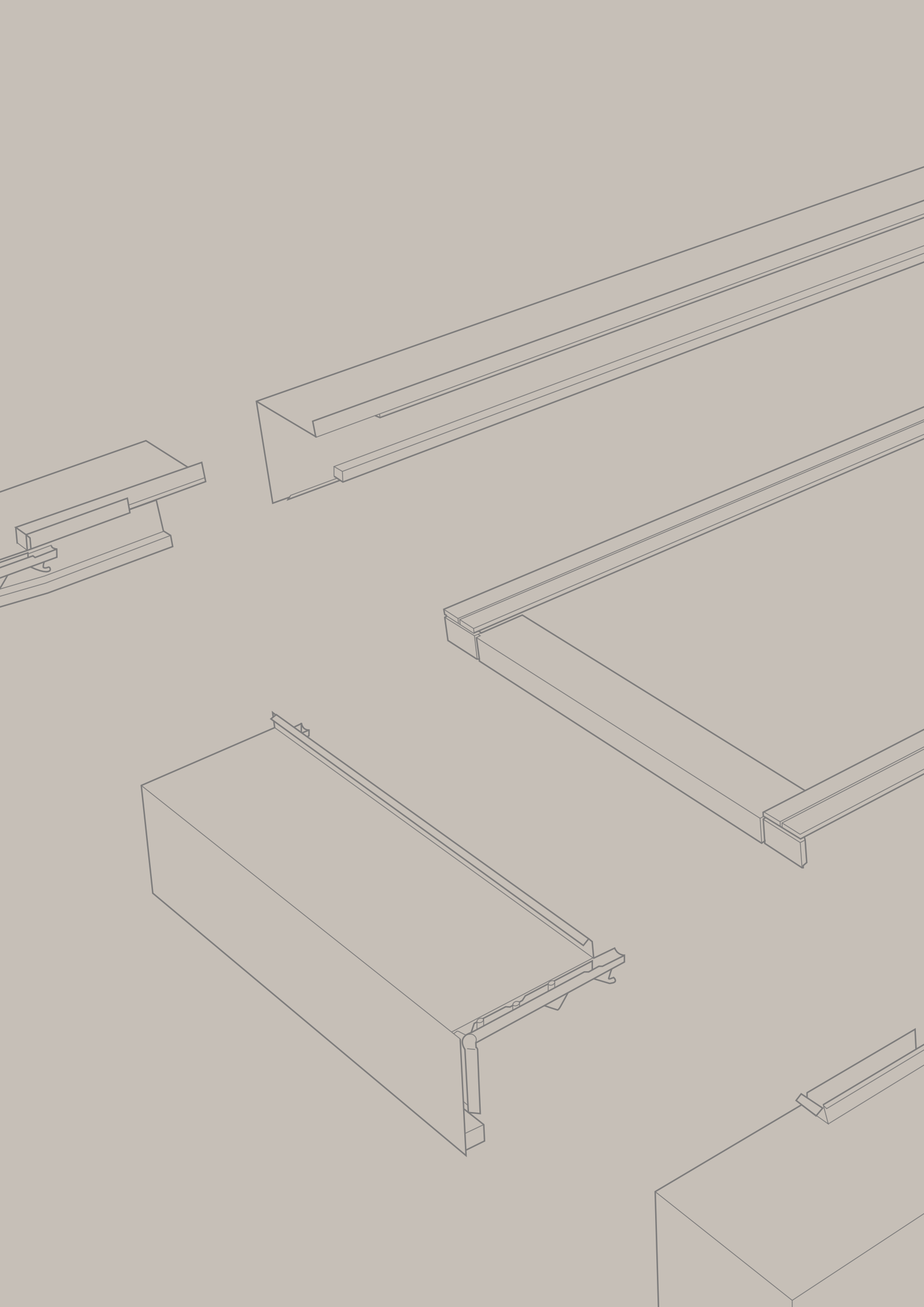



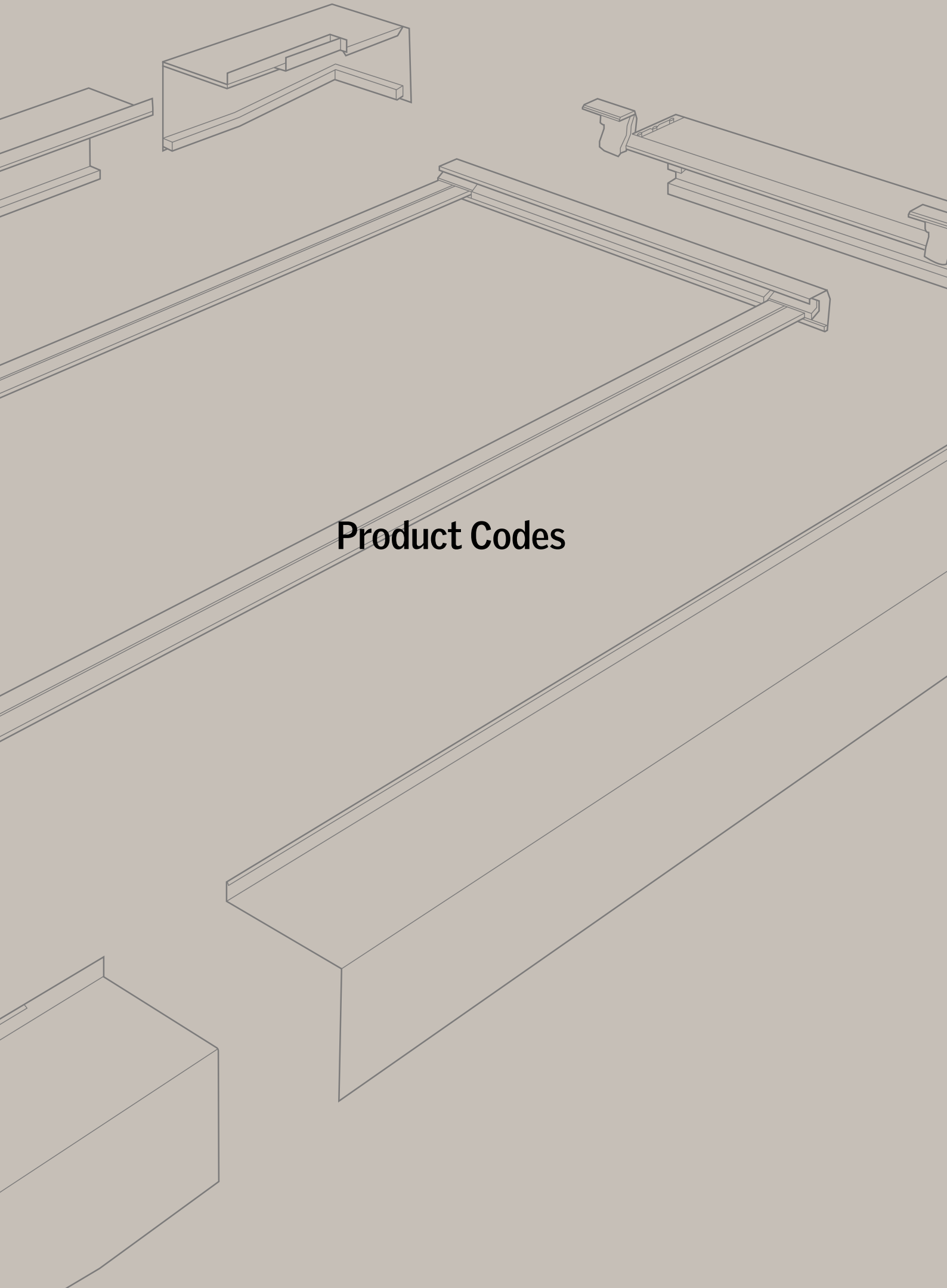

**Product Codes**

# Modular Skylights – code structure



Example

<b>HVC</b>		<b>067</b>		<b>160</b>		<b>0</b>		<b>0</b>		<b>10</b>		<b>T</b>		<b>C</b>		<b>B</b>	
Type	Module width	Module height	Interior colour	Exterior colour	Glazing type	Glazing variant	Electric variant	Generation									
H = VMS	067 = 675 mm	120 = 1200 mm	0 = std.	0 = std.	10 = DGU/LowE	L = 3+3 mm inner glass	A = Open-system/Smoke										
	075 = 750 mm	140 = 1400 mm	RAL colour 9010, gloss 30	Noir 2100 Sable	11 = DGU/Sun1												
F = Fixed	080 = 800 mm	<b>160 = 1600 mm</b>			12 = DGU/Sun2	<b>T = 5+5 mm inner glass</b>	<b>C = Open-system/Comfort</b>										
V = Venting	090 = 900 mm	180 = 1800 mm			16 = TGU/LowE	K = Krypton gas instead of the standard Argon gas, 5 + 5 mm inner glass.											
	100 = 1000 mm	200 = 2000 mm			17 = TGU/Sun1	U = Fire resistant											
C = Commercial market		220 = 2200 mm	8 = Special	8 = Special													
		240 = 2400 mm															
		260 = 2600 mm															
		280 = 2800 mm															
S = Fire-resistant variant. With fire resistant glazing unit and intumescent strip		300 = 3000 mm			18 = TGU/Sun2												

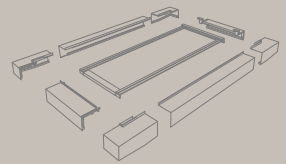

## Roller blinds – code structure



Example

RMM	067	160	8805
<b>Type</b>	<b>Module width</b>	<b>Module height</b>	<b>Fabric variant</b>
R = Roller blind	067 = 675 mm	120 = 1200 mm	8805 = Grey, fire retardant
	075 = 750 mm	140 = 1400 mm	8806 = White, fire retardant
M = Electrical	080 = 800 mm	160 = 1600 mm	8807 = Black, fire retardant
	090 = 900 mm	180 = 1800 mm	
M = For VELUX Modular Skylights	100 = 1000 mm	200 = 2000 mm	
		220 = 2200 mm	
		240 = 2400 mm	
		260 = 2600 mm	
		280 = 2800 mm	
		300 = 3000 mm	

## Product label – code structure



Product illustration

Module type    Module size    Colour variant

Pane type  
Pane variant  
Electrical variant  
Generation  
Order number

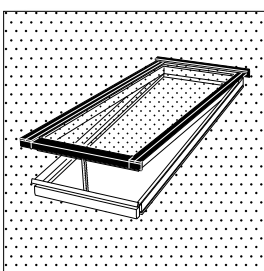

**HVC 090180 0010TCB**

Vented Module

Width (W) x Height (H)  
90 cm x 180 cm  
Volume 0.27 m<sup>3</sup>  
Weight 108 kg

(97)006008818863

(240)HVC 090180 0010

(95)5007156313(96)0020

HUSCOMPAGNIET - 29136802/Kim  
Ring ved lev  
ALDRERSHIVILEVEJ 153  
DK-2450 KBH S

Made in Denmark by the VELUX Group

Product dimensions and weight    EAN code    Delivery address

# Flashings – code structure

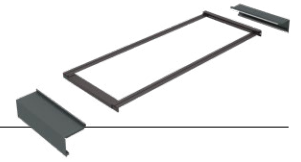

Longlight 5-30°

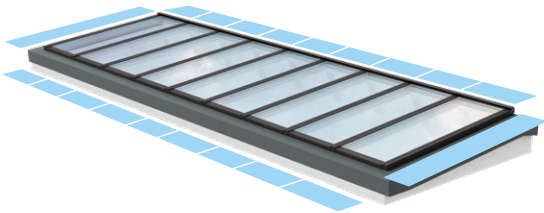

Ridgelight 25-40°

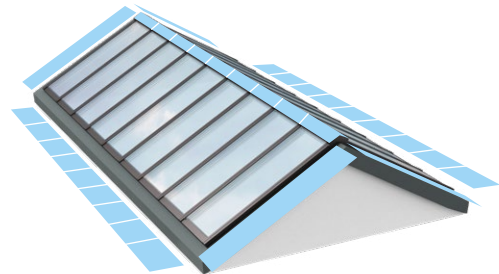

Wall-mounted Longlight 5-45°

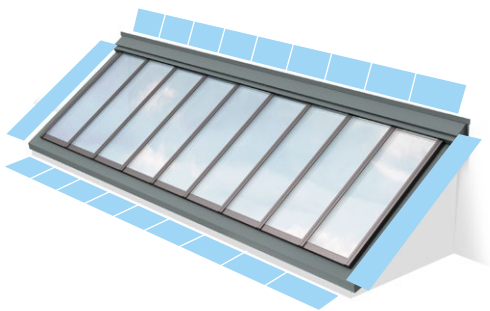

Ridgelight at 5° with Beams

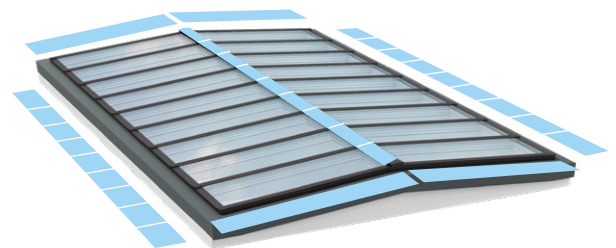

Northlight 25-90°

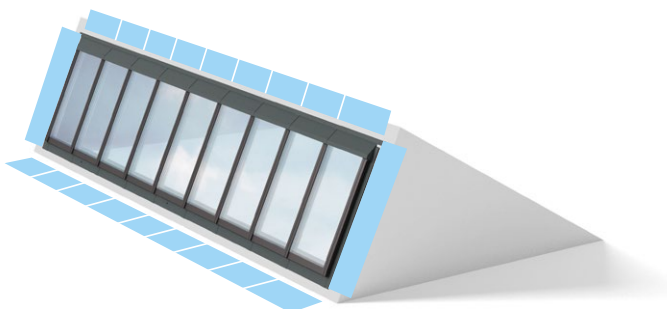

Step Longlight 5-25°

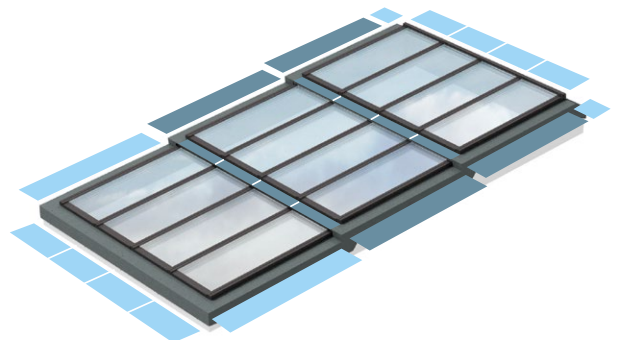

## Code structure

 Flashing configuration

 Step solution extension flashing

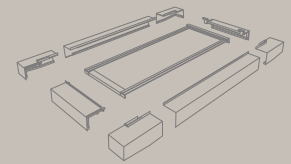

## Flashing configuration – code structure

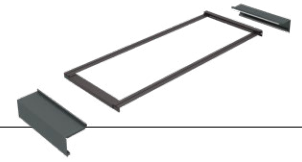

Example

ERC		080		160		0		0		0		25				D		B	
Type	Module width	Module height	Interior	Exterior flashing	Exterior cladding	Installation pitch				VMS Cover	Generation								
E = Flashing	067 = 675 mm	120 = 1200 mm	0 = std.	0 = std.	0 = std.	05 = 5°, 10 = 10° etc.				D = Extra cover									
	075 = 750 mm	140 = 1400 mm	Only relevant on ERC: Beams and Inner ridge covering	NCS standard colour: S 7500-N (RAL 7043)	Noir 2100 Sable	Standard pitches:				Extra Cover When HVC ≥ HFC	1 pcs for ELC/ EWC/ ENC								
L = Longlight	080 = 800 mm	160 = 1600 mm				ELC	ERC	EWC	ENC										
R = Ridgelight	090 = 900 mm	180 = 1800 mm				05	05	05											
N = Northlight	100 = 1000 mm	200 = 2000 mm				10		10											
W = Wall-mounted Longlight		220 = 2200 mm				15		15											
		240 = 2400 mm	20		20														
		260 = 2600 mm	25	25	25														
C = Commercial Market		280 = 2800 mm		8 = special	8 = special	30	30			2 pcs for ERC									
		300 = 3000 mm	RAL colour 9010, gloss 30			35	35												
			8 = special			40	40												
								25											
								55											

VELUX Group  
VELUX Commercial  
Ådalsvej 99  
2970 Hørsholm  
Denmark

Web: [veluxcommercial.com](http://veluxcommercial.com)  
Blog: [commercial.velux.com/blog](http://commercial.velux.com/blog)

Your preferred partner for  
**daylight and ventilation solutions**

**VELUX®**

**Commercial**

Version 6.5