



The internal roller blind RMR protects against heat and glare and helps to control the amount of light in the building

VELUX io-homecontrol® and Open System		
Materials (visible parts)	Fabric	Polyester
	Wire	Stainless steel
	Bottom rail	Anodized aluminium
	Top pulley wheels	Stainless steel
Colours (cloth)	Grey, white and black (silver on the backside of the black)	
Weight	Max 3.4 kg	
Size limitations	Please see size overview and limitations in Modular Rooflights Main Brochure.	
Installation	Please see installation instructions	
Compatibility	VELUX Modular Rooflights with VELUX io-homecontrol® and ±24 V DC control systems, except Monolight Walk-on and Circularlight.	
Control system	VELUX io-homecontrol® or ±24 V DC	
Supply cable	0.2 m cable, 2-core, 0.75 mm <sup>2</sup> (white, brown)	
RMR cable on rooflight module *, **	3.9 m cable through the upstand, 3-core, 0.75 mm <sup>2</sup> (white, brown, green***)	
Running speed	70 mm/sec.	
IP rating	IPX0	
Sound level	< 70 dB	
Operating conditions	-5°C - +75°C, max. 90% relative humidity (not condensing)	
Nominal voltage	24 V DC (max 10% ripple)	
Voltage	19-24 V DC	
Switch-on-duration	ED max 20% (2 minutes per 10 minutes)	
Electric current requirement	Max 1A	
Service	It is recommended to carry out a function test of the roller blind at least once a year and to make sure that the roller blind runs correctly.	
CE marking	The product is tested with VELUX control unit KLC 410 and a ±24 V DC control system and complies with the EMC directive's requirements for use in residential, commercial and light commercial buildings.	
Reservation	The VELUX Group reserves the right to make to technical changes.	

\*, \*\*, \*\*\* see next page

## Wiring length/dimension

\* For Open System  $\pm 24$  V DC connection, the maximum distance from roller blind to power supply is in accordance to the following calculation:

$$\text{Max.cable length} = \frac{(\text{admissible voltage drop (UL)} \times \text{conductivity of copper (56)} \times \text{cable cross-section (a)})}{(\text{total max. actuator current (I) in amps} \times 2)}$$

\*\* Only valid for pre-wired modules

\*\*\* Green cable has no function



The blind cloth of VELUX roller blinds is pulled on two tension steel wires on pulley wheels, which are accessible, when the roller blinds are installed on rooflights within reach and therefore can cause serious injury, if a person gets in contact with this during the electrical operation of the blind. VELUX roller blinds have a recommended minimum installation height of 2.5 m above floor level (inside) and ground level (outside).

In case of installation below that level, safety measures must be applied by the installer/user to prevent serious injury. No instruction or measure can eliminate the inherent hazards resulting from installation heights below 2.5 m.

We recommend you to observe national regulations and consider if the planned specific use of the building requires that additional safety measures must be applied by the installer/user to prevent serious injury.

The VELUX Group will not accept responsibility for damages, injury or death resulting from such installation. The installer/user is ultimately responsible for own omissions and actions. Measures could for instance be to install a motion sensor that is able to disconnect power from the control unit in case of any movement in the immediate vicinity of the VELUX Modular Rooflights.

## Technical values

Roller blind cloth properties			
Colour	White (8806)	Grey (8805)	Black (8807)
Radiation properties without glazing unit (%)			
Total solar energy transmittance (g-value)	37%	31%	15%
Light transmittance in visible light spectrum (tau, v)	36%	10%	1%
Light transmittance in full light spectrum (tau, e)	35%	22%	3%
Light reflectance in full light spectrum (rho, e)	59%	45%	53%
Light absorption in full light spectrum (alpha, e)	6%	33%	44%

Roller blind cloth properties	
Norm	Class
EN 13501-1 + A1	B, s1-d0
DIN 4202-1	B1
NF P 92 503-507	M1

## Technical values (continued)

Roller blind effects on double glazing unit (%)									
Glazing variant	20V			20Y			20Z		
	g-value	$\tau_v$ -value	$F_c$ -value	g-value	$\tau_v$ -value	$F_c$ -value	g-value	$\tau_v$ -value	$F_c$ -value
Without RMR	61%	80%	100%	61%	80%	100%	61%	79%	100%
With RMR									
<b>White (8806)</b>	39%	31%	64%	39%	31%	64%	39%	31%	64%
<b>Grey (8805)</b>	44%	8%	72%	44%	8%	72%	44%	8%	72%
<b>Black (8807)</b>	40%	1%	66%	40%	1%	66%	40%	1%	66%

Roller blind effects on double glazing unit (%)									
Glazing variant	22V			22Y			22Z		
	g-value	$\tau_v$ -value	$F_c$ -value	g-value	$\tau_v$ -value	$F_c$ -value	g-value	$\tau_v$ -value	$F_c$ -value
Without RMR	61%	80%	100%	61%	79%	100%	61%	79%	100%
With RMR									
<b>White (8806)</b>	39%	31%	64%	39%	31%	64%	39%	31%	64%
<b>Grey (8805)</b>	44%	8%	71%	44%	8%	71%	43%	8%	71%
<b>Black (8807)</b>	40%	1%	66%	40%	1%	66%	40%	1%	66%

Roller blind effects on double glazing unit (%)									
Glazing variant	21V / 23V			21Y / 23Y			21Z / 23Z		
	g-value	$\tau_v$ -value	$F_c$ -value	g-value	$\tau_v$ -value	$F_c$ -value	g-value	$\tau_v$ -value	$F_c$ -value
Without RMR	33%	61%	100%	33%	61%	100%	33%	60%	100%
With RMR									
<b>White (8806)</b>	27%	24%	80%	27%	24%	80%	26%	23%	80%
<b>Grey (8805)</b>	28%	6%	84%	28%	6%	84%	28%	6%	84%
<b>Black (8807)</b>	27%	1%	81%	27%	1%	81%	27%	1%	81%

## Technical values (continued)

Roller blind effects on triple glazing unit (%)									
Glazing variant	30V			30Y			30Z		
	g-value	$\tau_v$ -value	$F_c$ -value	g-value	$\tau_v$ -value	$F_c$ -value	g-value	$\tau_v$ -value	$F_c$ -value
Without RMR	53%	71%	100%	52%	71%	100%	52%	70%	100%
With RMR									
White (8806)	36%	28%	69%	36%	28%	69%	36%	28%	69%
Grey (8805)	40%	7%	76%	40%	7%	76%	39%	6%	76%
Black (8807)	38%	1%	71%	37%	1%	72%	37%	1%	72%

Roller blind effects on triple glazing unit (%)									
Glazing variant	32V			32Y			32Z		
	g-value	$\tau_v$ -value	$F_c$ -value	g-value	$\tau_v$ -value	$F_c$ -value	g-value	$\tau_v$ -value	$F_c$ -value
Without RMR	52%	71%	100%	52%	71%	100%	52%	70%	100%
With RMR									
White (8806)	36%	28%	69%	36%	28%	69%	36%	28%	69%
Grey (8805)	40%	7%	76%	40%	7%	76%	39%	7%	76%
Black (8807)	37%	1%	72%	37%	1%	72%	37%	1%	72%

Roller blind effects on triple glazing unit (%)									
Glazing variant	31V / 33V			31Y / 33Y			31Z / 33Z		
	g-value	$\tau_v$ -value	$F_c$ -value	g-value	$\tau_v$ -value	$F_c$ -value	g-value	$\tau_v$ -value	$F_c$ -value
Without RMR	30%	55%	100%	30%	55%	100%	30%	55%	100%
With RMR									
White (8806)	25%	22%	82%	25%	22%	82%	25%	22%	82%
Grey (8805)	26%	6%	86%	26%	6%	86%	26%	6%	86%
Black (8807)	25%	1%	83%	25%	1%	83%	25%	1%	83%

### g-value

The total transmitted fraction of the incident solar radiation consisting of direct transmitted solar radiation and the part of the absorbed solar radiation transferred by convection and thermal radiation to the internal environment. (EN 13363-2)

The fraction of the incident solar radiation that is totally transmitted by the glass. (EN 410)

The g-value (total solar energy transmittance) is a measure of how much solar energy is transmitted through the construction in the cooling period.

The g-value is defined as the ratio between the solar energy transmitted through the glazing and the incident solar factor on the glazing.

### $\tau_v$ -value:

The transmitted fraction of the incident solar radiation in the visible part of the solar spectrum, see EN 410. (EN 13363-2)

The fraction of incident light that is transmitted by the glass. (EN 410)

### $F_c$ -value:

The shading factor,  $F_c$ -value, is the ratio of the solar factor of the combined glazing and solar protection device,  $g_{tot}$ , to that of the glazing alone,  $g$ .  $F_c = g_{tot}/g$ .

Note: in some countries,  $F_c$  is known as z. (EN 14501)

## VELUX io-homecontrol®

VELUX io-homecontrol® is a simple wireless system for control of comfort venting modules and/or roller blinds. All components for VELUX io-homecontrol® (actuators, control panels, sensors, etc.) are supplied by the VELUX Group.

### Initialisation

1. Connect the roller blind to control unit KLC 410
2. The RMR must be registered in a VELUX operation device within 10 min. of being connected to the power supply
3. The RMR is now ready for operation.

### Calibration

The roller blind must be calibrated to the module, before it can be

operated. The calibration will take place automatically the first time the roller blind is operated and again after 10 operations.

An automatic calibration also occurs with every 250 operations. Before the roller blind runs to the desired position, it runs all the way up and down. Do not interrupt the adjustment!

In rare occasions, the roller blind will have to be calibrated manually, if it e.g. does not stop at the right position at the top or bottom. To manually calibrate the roller blind:

- switch off the power for min. 10 sec.
- within 30 seconds after reconnection, press the STOP key and subsequently the UP/DOWN key on the operation device.

## Fixed Modular Rooflights with sun screening

Combination with fixed Modular Rooflights with roller blinds RMR.

### Electrical diagrams

Fixed Modular Rooflights with sun screening

This combination consists of four fixed Modular Rooflights with roller blinds RMR.

### Possibilities and limitations





One control unit KLC 410 per four fixed Modular Rooflights with roller blinds RMR is required. Control unit KLC 410 can be positioned up to 20 m from it and is supplied with cables for connecting up to four roller blinds RMR in series.

Roller blinds RMR can be operated from either one of the following or a combination of:

- control pad KLR 200/KLR 300 – individual or simultaneous operation
- wall switch KLI 312 – simultaneous operation.

The operational range between a roller blind and the control unit is approximately 30 metres indoors. However, depending on the building construction and materials, the range can be longer. If needed, the range can be extended by using VELUX interface KLF 200 as a signal repeater station.

### Operation

	Control unit	KLC 410	Requires 230 V AC supply	Power consumption max 250 W
	Control pad	KLR 200/KLR 300	Handheld or wall-mounted	Requires batteries
	Wall switch	KLI 312	Wall-mounted	Requires batteries
	Interface	KLF 200	Requires 230 V AC supply	

Installations	Number of UVM/UVL with RMR per installation	Number of KLC 410
1	1-4	1
1	5-8	2
2	1-4	2

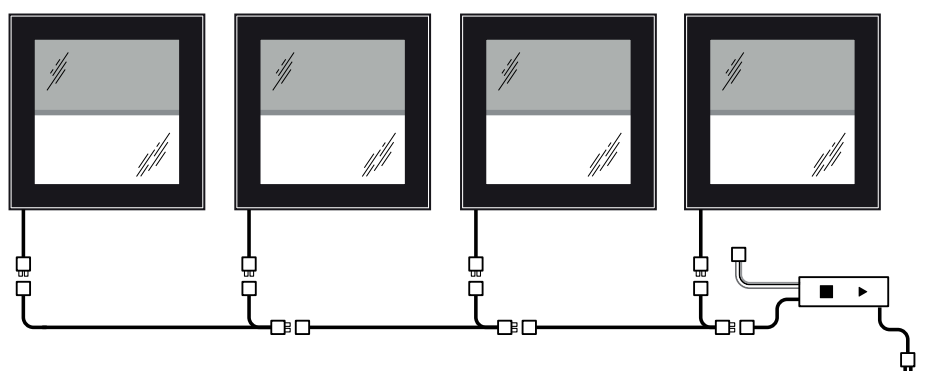

Fixed Modular Rooflights with sun screening

230 V

## Fixed and venting Modular Rooflights with sun screening

Combination with fixed Modular Rooflights and venting Modular Rooflights with roller blinds RMR.

### Possibilities and limitations

One control unit KLC 410 per one venting Modular Rooflight and three fixed Modular Rooflight with roller blinds RMR is required. Subsequently, one control unit KLC 410 per four fixed Modular Rooflight with roller blinds RMR is required. Control unit KLC 410 can be positioned up to 20 m from it and is supplied with cables for connecting up to four roller blinds RMR in series and one venting Modular Rooflight within the same installation.

The operational range between the Modular Rooflight and the control unit is approximately 30 metres indoors. However, depending on the building construction and materials, the range can be longer.

If needed, the range can be extended by using interface KLF 200 as a signal repeater station.

### Operation





Venting Modular Rooflight and roller blinds RMR can be operated from either one of the following or a combination of:

- control pad KLR 200/KLR 300 – individual or simultaneous operation
- wall switch KLI 311 – simultaneous operation of modules
- wall switch KLI 312 – simultaneous operation of roller blinds.

### Recommendation

It is recommended to install a rain sensor that will close the Modular Rooflight in case of rain. KLA 200 is a small rain sensor mounted directly on every venting module.

**Note:** Only one repeater is possible between interface and control unit.

 Control unit	KLC 410	Requires 230 V AC supply	Power consumption max 250 W
 Control pad	KLR 200/KLR 300	Hand held or wall-mounted	Requires batteries
 Wall switch	KLI 311 KLI 312	Wall-mounted	Requires batteries
 Interface	KLF 200	Requires 230 V AC supply	
 Rain sensor	KLA 200	Requires KLC 410	

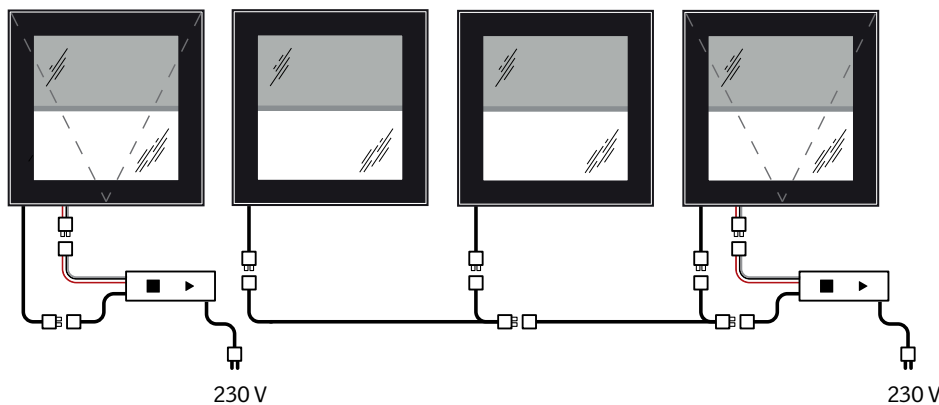
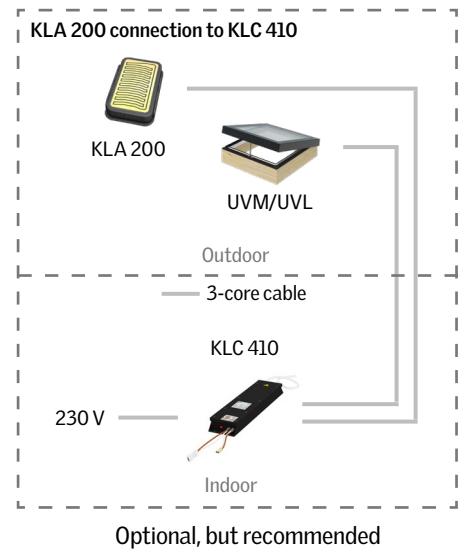

Fixed and venting Modular Rooflights with sun screening

## Open System

Open System is a 24V DC control system, which can be integrated in common building management automation fieldbus systems, e.g. KNX, BACnet, LON and Modbus, through the integrated MotorLink™ technology.

Connection to a fieldbus system requires a separate control box between fieldbus system and roller blind. With Open System, only the roller blind is supplied by the VELUX Group.

### Initialization

#### ±24V DC

1. Connect the white and brown cords on the modules' RMR cable to a power supply.
2. The RMR is now ready for operation.

### Calibration

The motor must be adjusted to the size of the module before the roller blind can be operated. The adjustment will take place automatically the first time the roller blind is operated and again after 10 operations. An automatic calibration also occurs with every 250 operations. Before the roller blind runs to the desired position, it runs all the way up and down. Do not interrupt the adjustment!

In rare occasions, the RMR will have to be calibrated manually, if it e.g. does not stop at the right position at the top or bottom.

To manually calibrate the roller blind:

- Ensure that the roller blind is in the top position
- Press the UP function on your wall switch 5 times in a row, for at least one second at a time
- Press DOWN on your wall switch.

#### Important information

- All information in the RMR Declaration of Conformity applies!

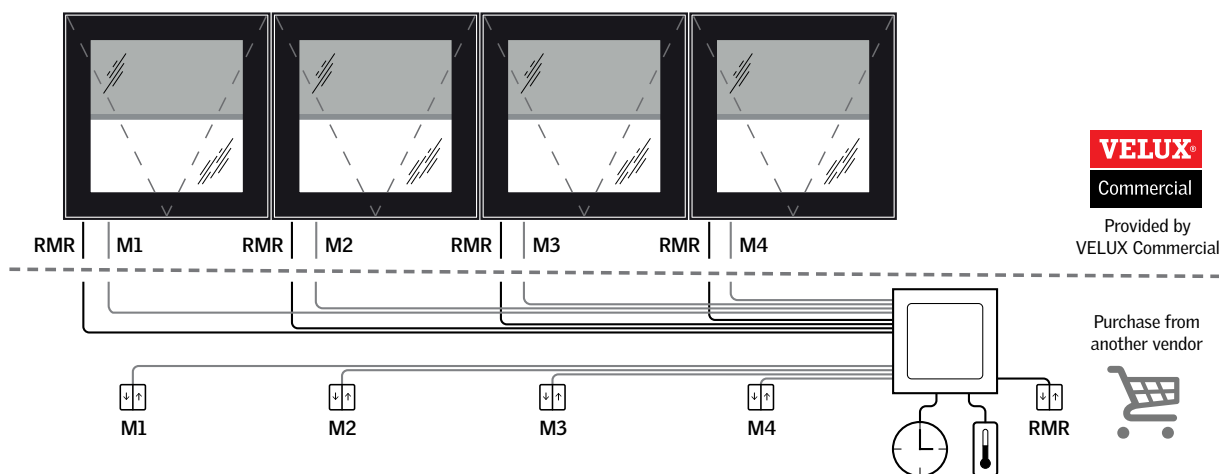

### Wiring length/dimension

Max cable length when roller blind connected to power supply							
Cable cross-section (a)	3 x 0.75 mm <sup>2</sup>	33 x 1.50 mm <sup>2</sup>	3 x 2.50 mm <sup>2</sup>	3 x 4.00 mm <sup>2</sup>	3 x 6.00 mm <sup>2</sup>	5 x 1.50 mm <sup>2</sup> 2 cords in parallel	5 x 2.50 mm <sup>2</sup> 2 cords in parallel
Total RMR current (I)							
1A	42 m	84 m	140 m	224 m	336 m	168 m	280 m
2A	21 m	42 m	70 m	112 m	168 m	84 m	140 m
3A	14 m	28 m	47 m	75 m	112 m	56 m	93 m
4A	11 m	21 m	35 m	56 m	84 m	42 m	70 m

### Connection of roller blind (RMR)

For correct connection to control system, see control system instructions.

		White	Brown
±24 V DC	UP	-	+
	DOWN	+	-

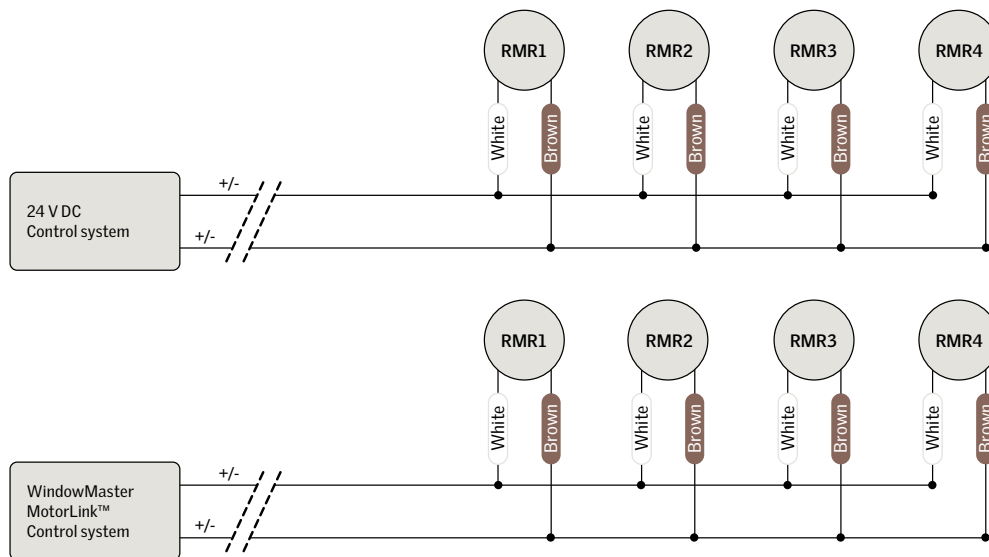

### Code structure

#### Example

RMR	097	097	8805
Type	RMR width	RMR height	Fabric variant
R = Roller blinds	097 = 970 mm	097 = 970 mm	8805 = Grey, fire retardent
	999 = special width	147 = 1470 mm	8806 = White, fire retardent
M = Electrical		197 = 1970 mm	8807 = Black, fire retardent
		999 = special height	
R = For VELUX Modular Rooflights			



17091-423 Valid from release date to new submission. Status: April 2024. We reserve the right to make printing errors, errors and changes in content.